

ALBUM

SHITJESH

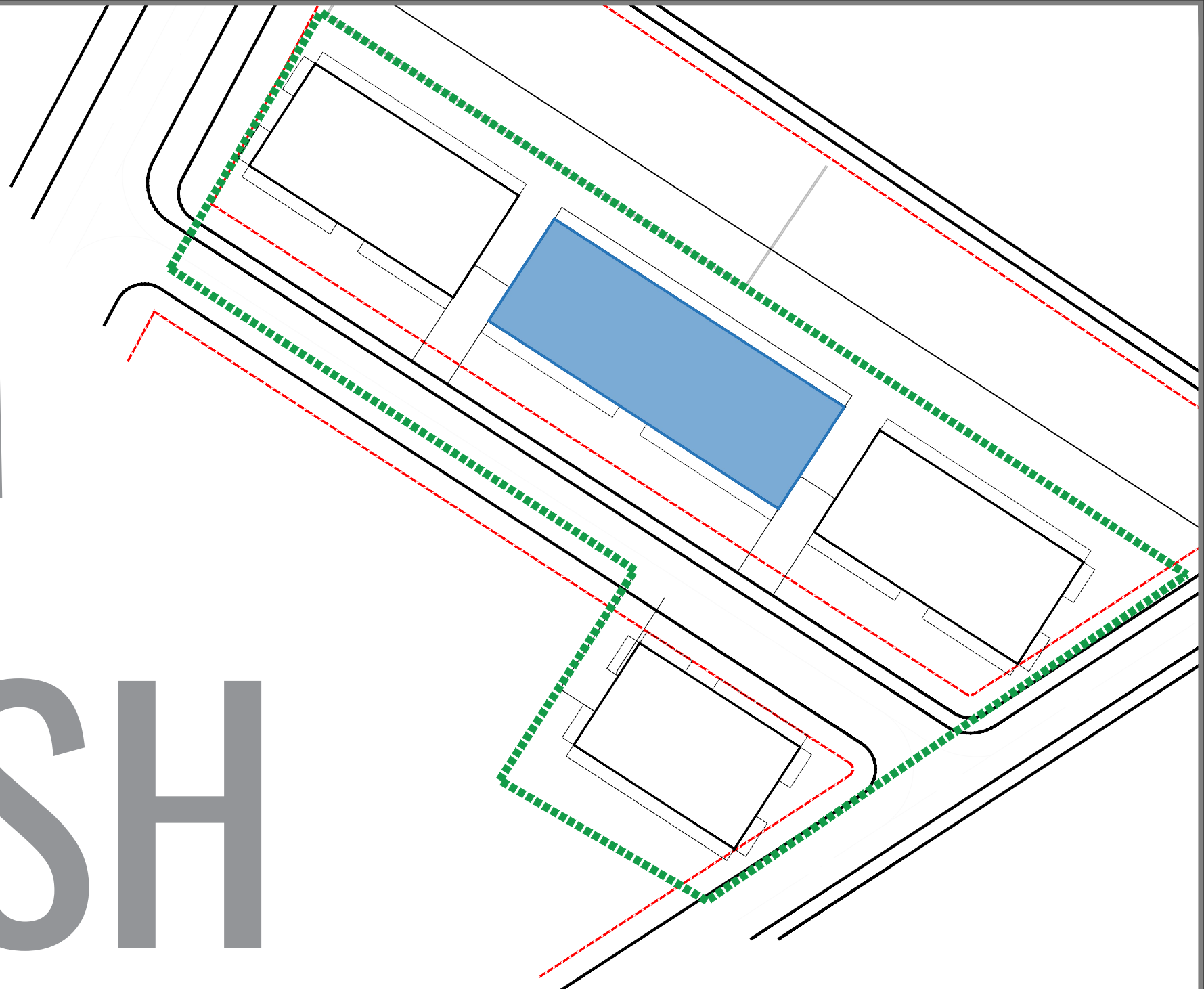

“4 GODINA BANIMI DHE SHËRBIMI 5 KATE DHE 1 KAT PARKIM NËNTOKË”

OBJEKTI 2

“4 GODINA BANIMI DHE SHËRBIMI 5 KATE DHE 1 KAT PARKIM NËNTOKË”
Adresa: Pavarsia e Kosovës, Golem - Bashkia Kavajë

INVESTITOR DHE SUBJEKT NDERTUES:

"LOREDIS" Sh.p.k
NIPT: M32202503U
Kavajë / Albania
Tel: +355694080880

PROJEKTUES:

VAEKU STUDIO
NIPT: M11319016N
Adresa: "Kompleksi Magnet",
Njësia Lyra 2018_1
Njësia Administrative Nr.7
Tiranë/Albania
E-mail: u.hoxha@vaeku.studio
Tel: +355674088492



APARTAMENTI NR:

P2

Objekti Nr :

2

Kati :

0

Orientimi :

JUG

Siperfaqe Apartamenti :

49.0 m²

Ambjente te perbashketa:

5.3 m²

Siperfaqe totale:

54.3 m²

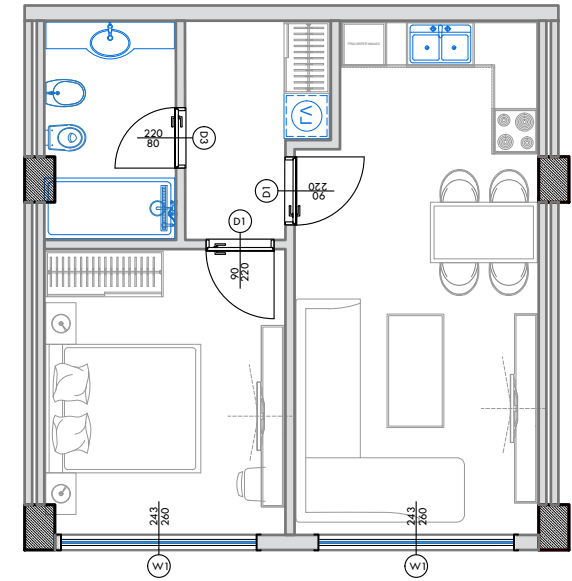
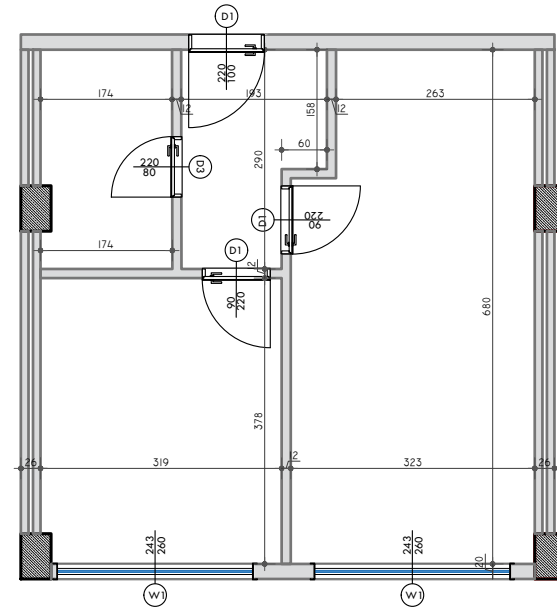

PLANIMETRIA E APARTAMENTIT - PERMASIM

SHKALLA 1:100

PLANIMETRIA E APARTAMENTIT - MOBILIM

SHKALLA 1:100

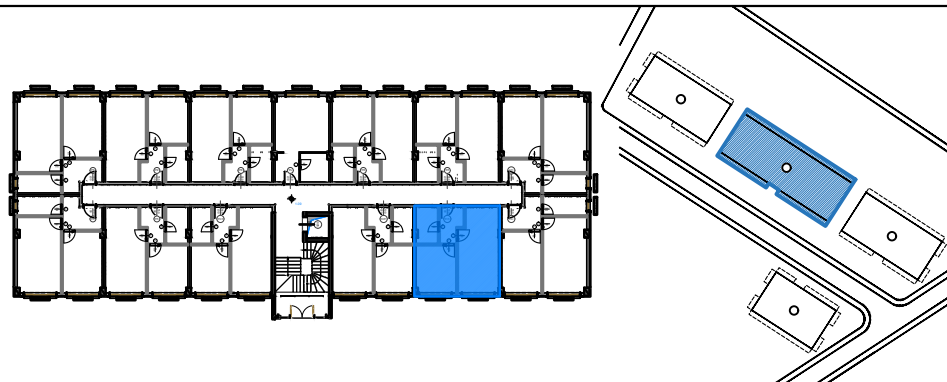

POZICIONI I APARTAMENTIT NE PLANIMETRINE E KATIT



POZICIONI I APARTAMENTIT NE ALTIMETRI - FASADA JUGORE



PAMJE 3 DIMENSIONALE E APARTAMENTIT

NR.1



PAMJE 3 DIMENSIONALE E APARTAMENTIT

NR.2

“4 GODINA BANIMI DHE SHËRBIMI 5 KATE DHE 1 KAT PARKIM NËNTOKË”
Adresa: Pavarsia e Kosovës, Golem - Bashkia Kavajë

INVESTITOR DHE SUBJEKT NDERTUES:

"LOREDIS" Sh.p.k
NIPT: M32202503U
Kavajë / Albania
Tel: +355694080880

PROJEKTUES:

VAEKU STUDIO
NIPT: M11319016N
Adresa: "Kompleksi Magnet",
Njësia Lyra 2018_1
Njësia Administrative Nr.7
Tiranë/Albania
E-mail: u.hoxha@vaeku.studio
Tel: +355674088492



APARTAMENTI NR:

P3

Objekti Nr :

2

Kati :

0

Orientimi :

JUG

Siperfaqe Apartamenti :

55.2 m²

Ambjente te perbashketa:

5.9 m²

Siperfaqe totale:

61.1 m²

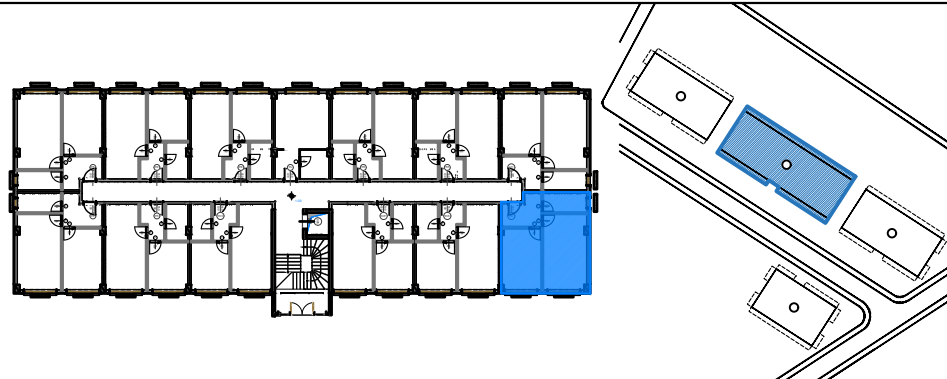
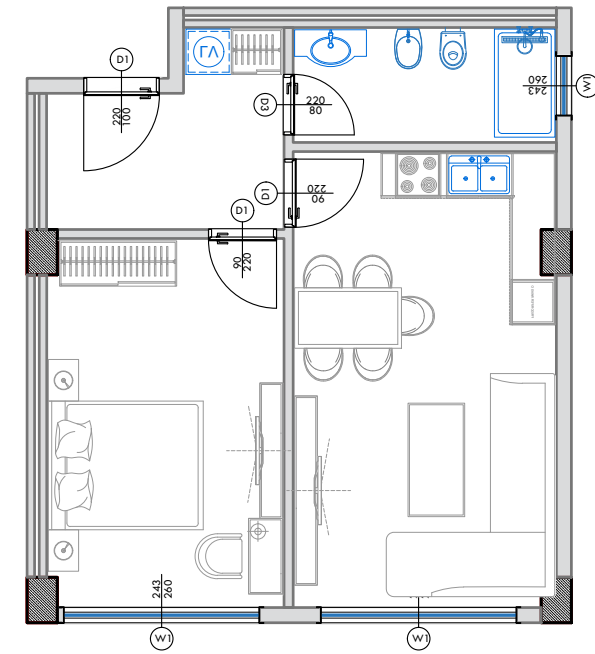
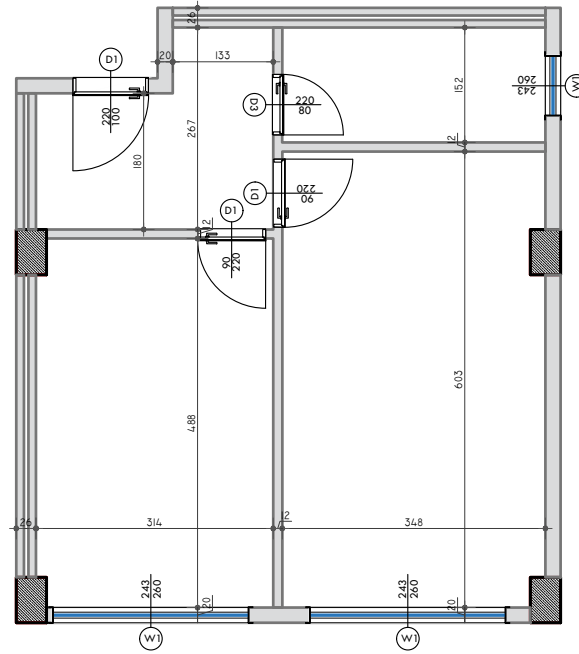

POZICIONI I APARTAMENTIT NE PLANIMETRINE E KATIT



POZICIONI I APARTAMENTIT NE ALTIMETRI - FASADA JUGORE

PLANIMETRIA E APARTAMENTIT - PERMASIM

SHKALLA 1:100

PLANIMETRIA E APARTAMENTIT - MOBILIM

SHKALLA 1:100



PAMJE 3 DIMENSIONALE E APARTAMENTIT

NR.1



PAMJE 3 DIMENSIONALE E APARTAMENTIT

NR.2

“4 GODINA BANIMI DHE SHËRBIMI 5 KATE DHE 1 KAT PARKIM NËNTOKË”
Adresa: Pavarsia e Kosovës, Golem - Bashkia Kavajë

INVESTITOR DHE SUBJEKT NDERTUES:

"LOREDIS" Sh.p.k
NIPT: M32202503U
Kavajë / Albania
Tel: +355694080880

PROJEKTUES:

VAEKU STUDIO
NIPT: M11319016N
Adresa: "Kompleksi Magnet",
Njësia Lyra 2018_1
Njësia Administrative Nr.7
Tiranë/Albania
E-mail: u.hoxha@vaeku.studio
Tel: +355674088492



APARTAMENTI NR:

P4

Objekti Nr :

2

Kati :

0

Orientimi :

VERI

Siperfaqe Apartamenti :

55.2 m²

Ambjente te perbashketa:

5.9 m²

Siperfaqe totale:

61.1 m²

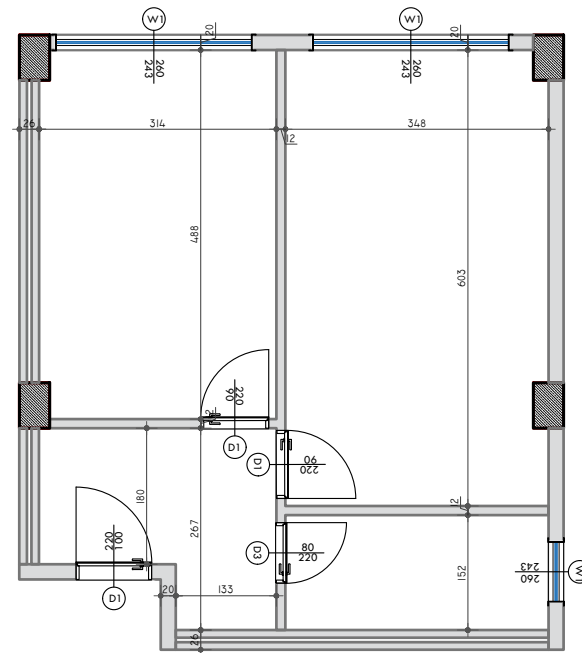

PLANIMETRIA E APARTAMENTIT - PERMASIM

SHKALLA 1:100

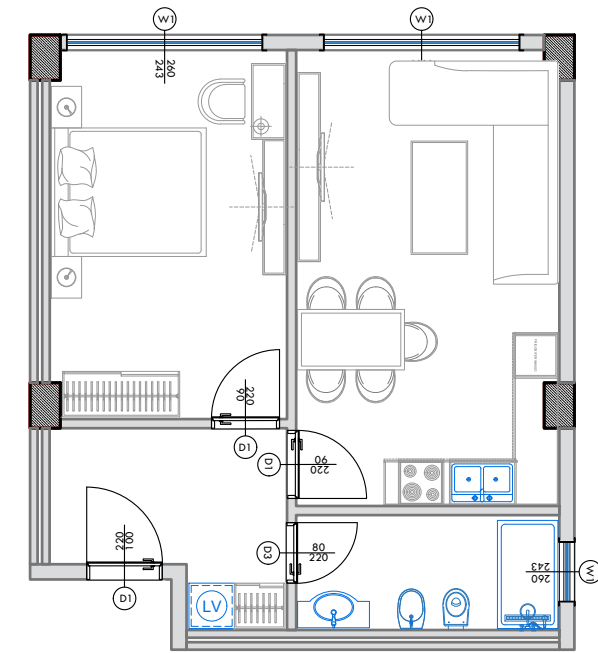

PLANIMETRIA E APARTAMENTIT - MOBILIM

SHKALLA 1:100

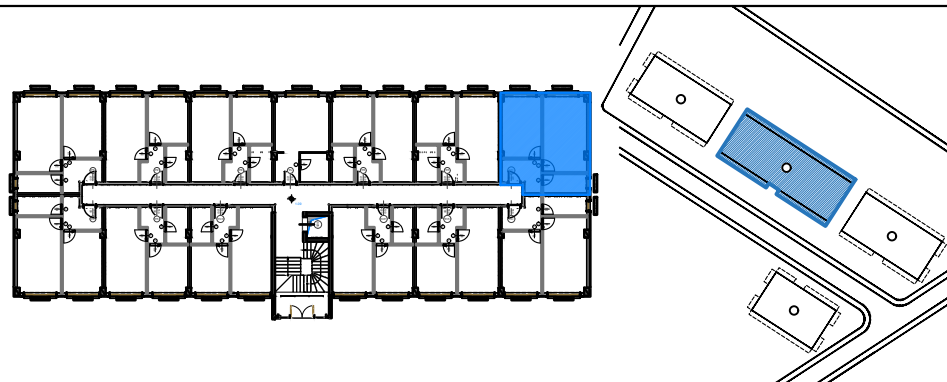

POZICIONI I APARTAMENTIT NE PLANIMETRINE E KATIT



POZICIONI I APARTAMENTIT NE ALTIMETRI - FASADA VERIORE



PAMJE 3 DIMENSIONALE E APARTAMENTIT

NR.1



PAMJE 3 DIMENSIONALE E APARTAMENTIT

NR.2

“4 GODINA BANIMI DHE SHËRBIMI 5 KATE DHE 1 KAT PARKIM NËNTOKË”
Adresa: Pavarsia e Kosovës, Golem - Bashkia Kavajë

INVESTITOR DHE SUBJEKT NDERTUES:

"LOREDIS" Sh.p.k
NIPT: M32202503U
Kavajë / Albania
Tel: +355694080880

PROJEKTUES:

VAEKU STUDIO
NIPT: M11319016N
Adresa: "Kompleksi Magnet",
Njësia Lyra 2018_1
Njësia Administrative Nr.7
Tiranë/Albania
E-mail: u.hoxha@vaeku.studio
Tel: +355674088492



APARTAMENTI NR:

P5

Objekti Nr :

2

Kati :

0

Orientimi :

VERI

Siperfaqe Apartamenti :

49.0 m²

Ambjente te perbashketa:

5.3 m²

Siperfaqe totale:

54.3 m²

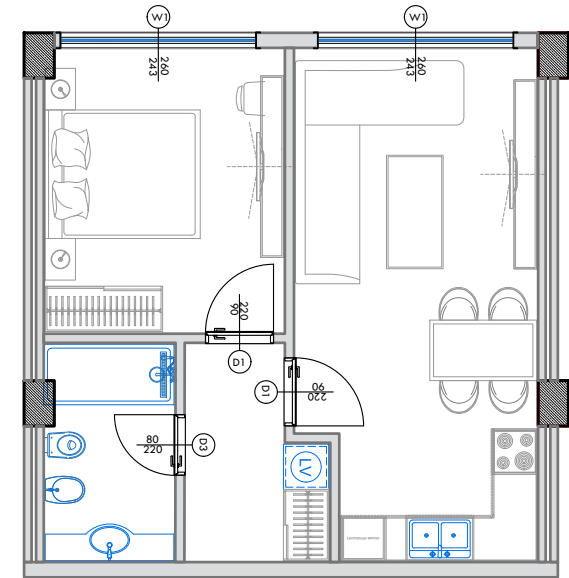
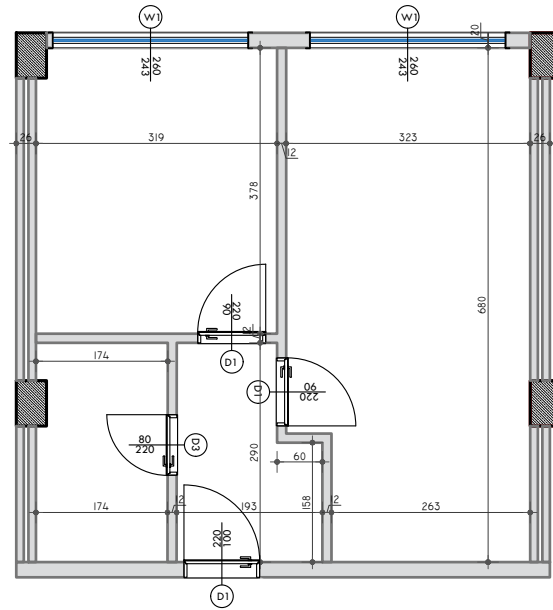

PLANIMETRIA E APARTAMENTIT - PERMASIM

SHKALLA 1:100

PLANIMETRIA E APARTAMENTIT - MOBILIM

SHKALLA 1:100

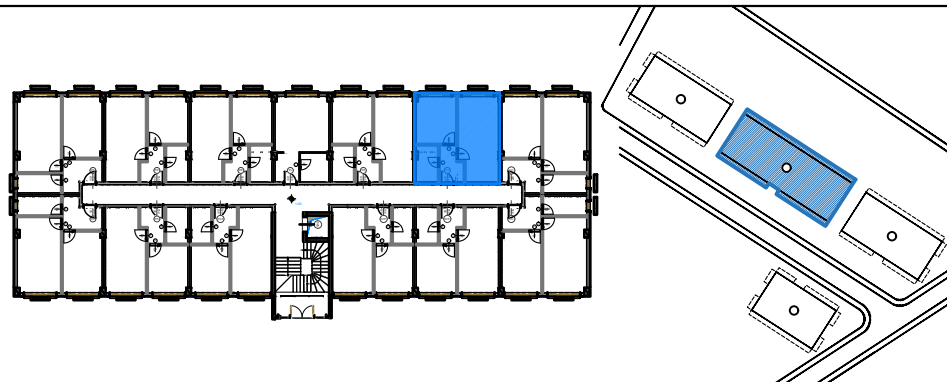

POZICIONI I APARTAMENTIT NE PLANIMETRINE E KATIT



POZICIONI I APARTAMENTIT NE ALTIMETRI - FASADA VERIORE



PAMJE 3 DIMENSIONALE E APARTAMENTIT

NR.1



PAMJE 3 DIMENSIONALE E APARTAMENTIT

NR.2

“4 GODINA BANIMI DHE SHËRBIMI 5 KATE DHE 1 KAT PARKIM NËNTOKË”
Adresa: Pavarsia e Kosovës, Golem - Bashkia Kavajë

INVESTITOR DHE SUBJEKT NDERTUES:

"LOREDIS" Sh.p.k
NIPT: M32202503U
Kavajë / Albania
Tel: +355694080880

PROJEKTUES:

VAEKU STUDIO
NIPT: M11319016N
Adresa: "Kompleksi Magnet",
Njësia Lyra 2018_1
Njësia Administrative Nr.7
Tiranë/Albania
E-mail: u.hoxha@vaeku.studio
Tel: +355674088492



APARTAMENTI NR:

P6

Objekti Nr :

2

Kati :

0

Orientimi :

VERI

Siperfaqe Apartamenti :

49.0 m²

Ambjente te perbashketa:

5.3 m²

Siperfaqe totale:

54.3 m²

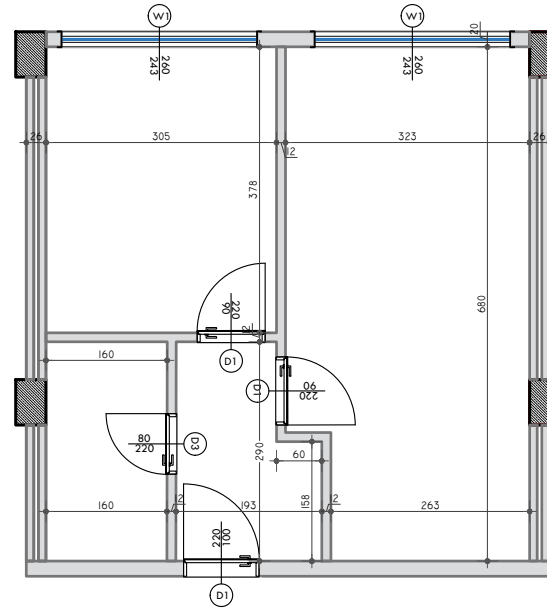

PLANIMETRIA E APARTAMENTIT - PERMASIM

SHKALLA 1:100

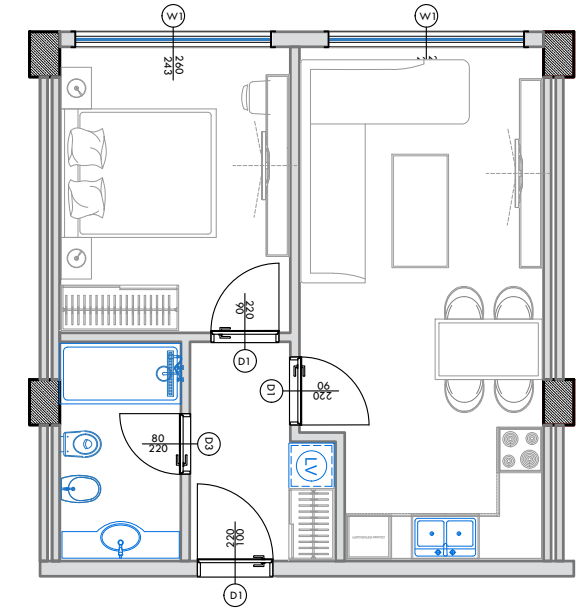

PLANIMETRIA E APARTAMENTIT - MOBILIM

SHKALLA 1:100

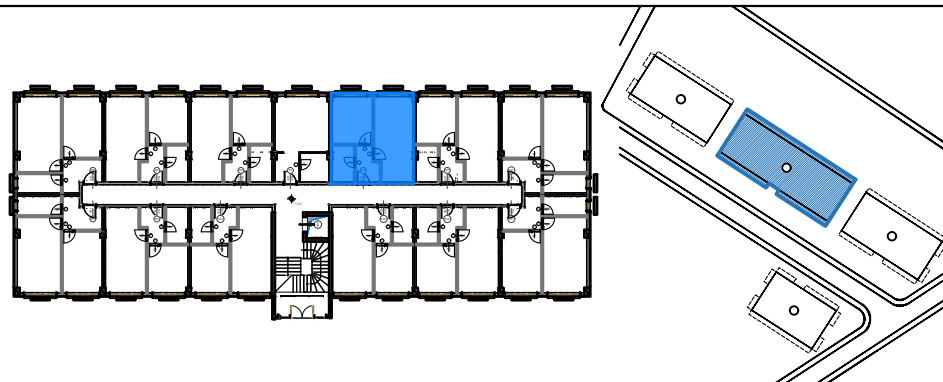

POZICIONI I APARTAMENTIT NE PLANIMETRINE E KATIT



POZICIONI I APARTAMENTIT NE ALTIMETRI - FASADA VERIORE



PAMJE 3 DIMENSIONALE E APARTAMENTIT

NR.1



PAMJE 3 DIMENSIONALE E APARTAMENTIT

NR.2

“4 GODINA BANIMI DHE SHËRBIMI 5 KATE DHE 1 KAT PARKIM NËNTOKË”
Adresa: Pavarsia e Kosovës, Golem - Bashkia Kavajë

INVESTITOR DHE SUBJEKT NDERTUES:

"LOREDIS" Sh.p.k
NIPT: M32202503U
Kavajë / Albania
Tel: +355694080880

PROJEKTUES:

VAEKU STUDIO
NIPT: M11319016N
Adresa: "Kompleksi Magnet",
Njësia Lyra 2018_1
Njësia Administrative Nr.7
Tiranë/Albania
E-mail: u.hoxha@vaeku.studio
Tel: +355674088492



APARTAMENTI NR:

P7

Objekti Nr :

2

Kati :

0

Orientimi :

VERI

Siperfaqe Apartamenti :

30.7 m²

Ambjente te perbashketa:

3.3 m²

Siperfaqe totale:

34.0 m²



SHITUR B

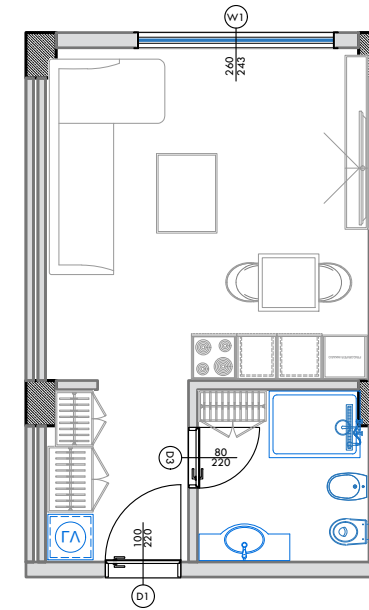
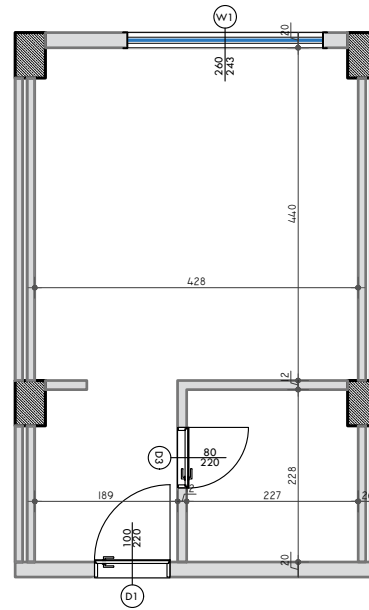

PLANIMETRIA E APARTAMENTIT - PERMASIM

SHKALLA 1:100

PLANIMETRIA E APARTAMENTIT - MOBILIM

SHKALLA 1:100

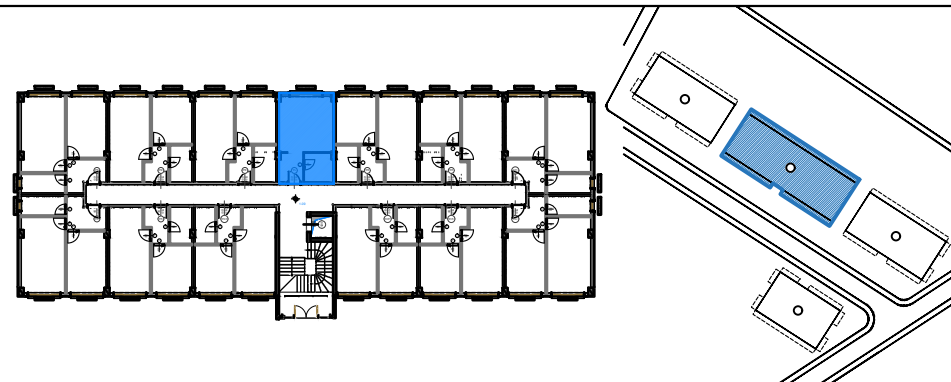

POZICIONI I APARTAMENTIT NE PLANIMETRINE E KATIT



POZICIONI I APARTAMENTIT NE ALTIMETRI - FASADA VERIORE



PAMJE 3 DIMENSIONALE E APARTAMENTIT

NR.1



PAMJE 3 DIMENSIONALE E APARTAMENTIT

NR.2

“4 GODINA BANIMI DHE SHËRBIMI 5 KATE DHE 1 KAT PARKIM NËNTOKË”
Adresa: Pavarsia e Kosovës, Golem - Bashkia Kavajë

INVESTITOR DHE SUBJEKT NDERTUES:

"LOREDIS" Sh.p.k
NIPT: M32202503U
Kavajë / Albania
Tel: +355694080880

PROJEKTUES:

VAEKO STUDIO
NIPT: M11319016N
Adresa: "Kompleksi Magnet",
Njësia Lyra 2018_1
Njësia Administrative Nr.7
Tiranë/Albania
E-mail: u.hoxha@vaeku.studio
Tel: +355674088492



APARTAMENTI NR:

P8

Objekti Nr :

2

Kati :

0

Orientimi :

VERI

Siperfaqe Apartamenti :

49.0 m²

Ambjente te perbashketa:

5.3 m²

Siperfaqe totale:

54.3 m²

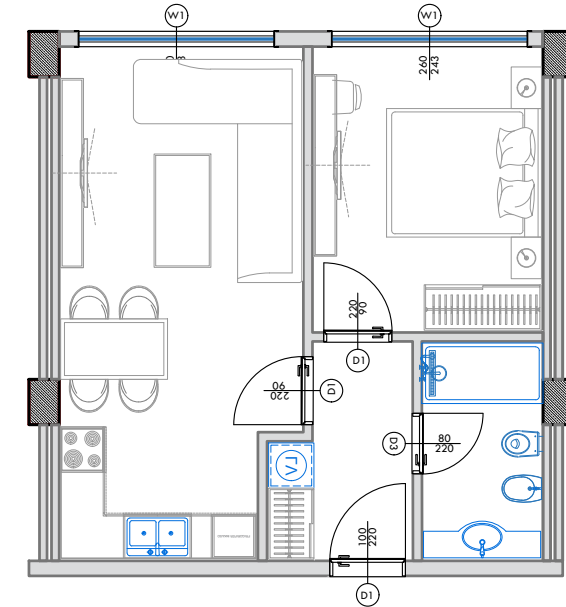
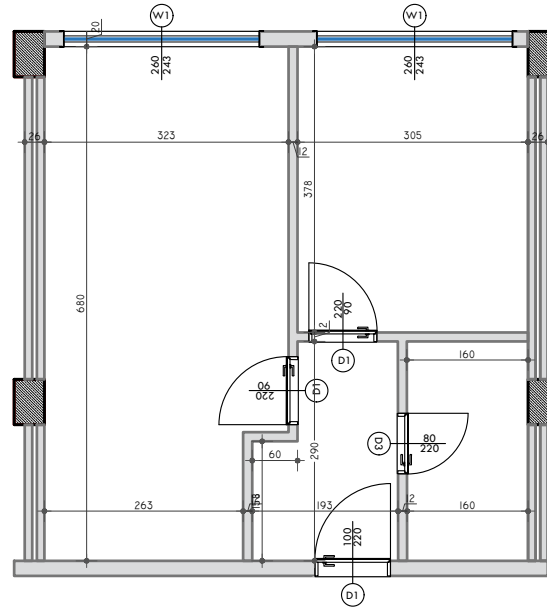

PLANIMETRIA E APARTAMENTIT - PERMASIM

SHKALLA 1:100

PLANIMETRIA E APARTAMENTIT - MOBILIM

SHKALLA 1:100

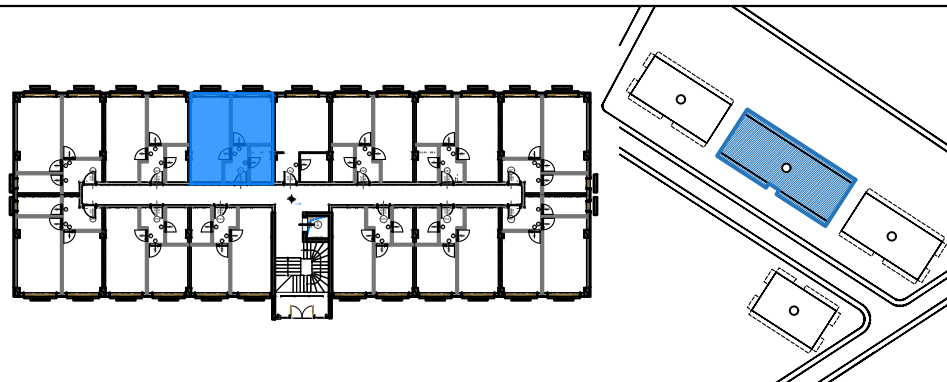

POZICIONI I APARTAMENTIT NE PLANIMETRINE E KATIT



POZICIONI I APARTAMENTIT NE ALTIMETRI - FASADA VERIORE



PAMJE 3 DIMENSIONALE E APARTAMENTIT

NR.1



PAMJE 3 DIMENSIONALE E APARTAMENTIT

NR.2

“4 GODINA BANIMI DHE SHËRBIMI 5 KATE DHE 1 KAT PARKIM NËNTOKË”
Adresa: Pavarsia e Kosovës, Golem - Bashkia Kavajë

INVESTITOR DHE SUBJEKT NDERTUES:

"LOREDIS" Sh.p.k
NIPT: M32202503U
Kavajë / Albania
Tel: +355694080880

PROJEKTUES:

VAEKU STUDIO
NIPT: M11319016N
Adresa: "Kompleksi Magnet",
Njësia Lyra 2018_1
Njësia Administrative Nr.7
Tiranë/Albania
E-mail: u.hoxha@vaeku.studio
Tel: +355674088492



APARTAMENTI NR:

P9

Objekti Nr :

2

Kati :

0

Orientimi :

VERI

Siperfaqe Apartamenti :

49.0 m²

Ambjente te perbashketa:

5.3 m²

Siperfaqe totale:

54.3 m²

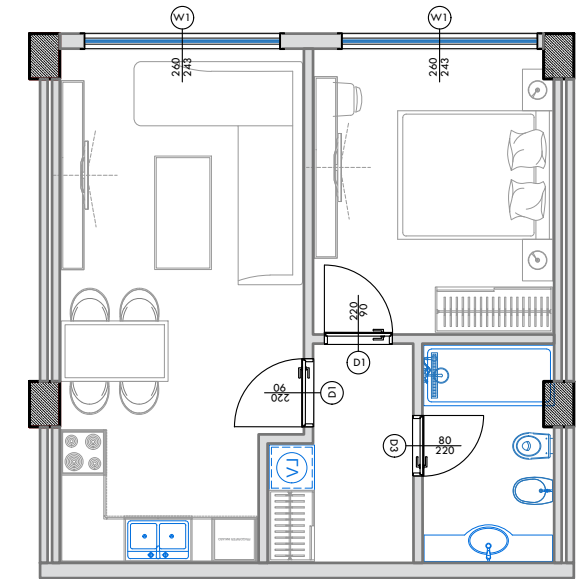
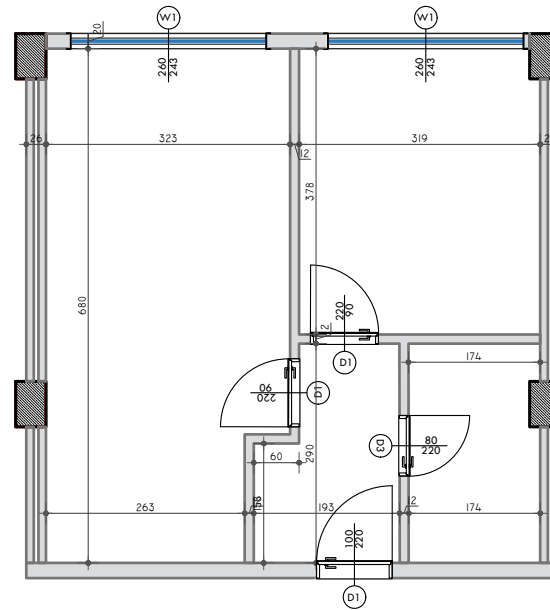

PLANIMETRIA E APARTAMENTIT - PERMASIM

SHKALLA 1:100

PLANIMETRIA E APARTAMENTIT - MOBILIM

SHKALLA 1:100

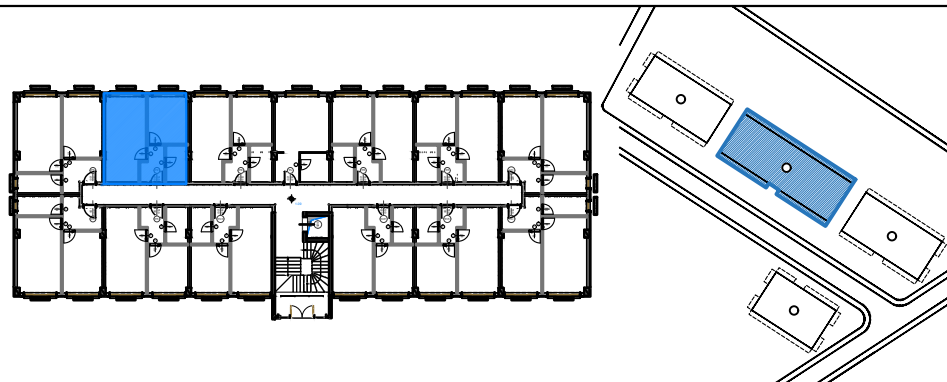

POZICIONI I APARTAMENTIT NE PLANIMETRINE E KATIT



POZICIONI I APARTAMENTIT NE ALTIMETRI - FASADA VERIORE



PAMJE 3 DIMENSIONALE E APARTAMENTIT

NR.1



PAMJE 3 DIMENSIONALE E APARTAMENTIT

NR.2

“4 GODINA BANIMI DHE SHËRBIMI 5 KATE DHE 1 KAT PARKIM NËNTOKË”
Adresa: Pavarsia e Kosovës, Golem - Bashkia Kavajë

INVESTITOR DHE SUBJEKT NDERTUES:

"LOREDIS" Sh.p.k
NIPT: M32202503U
Kavajë / Albania
Tel: +355694080880

PROJEKTUES:

VAEKU STUDIO
NIPT: M11319016N
Adresa: "Kompleksi Magnet",
Njësia Lyra 2018_1
Njësia Administrative Nr.7
Tiranë/Albania
E-mail: u.hoxha@vaeku.studio
Tel: +355674088492



APARTAMENTI NR:

P10

Objekti Nr :

2

Kati :

0

Orientimi :

VERI

Siperfaqe Apartamenti :

55.2 m²

Ambjente te perbashketa:

5.9 m²

Siperfaqe totale:

61.1 m²

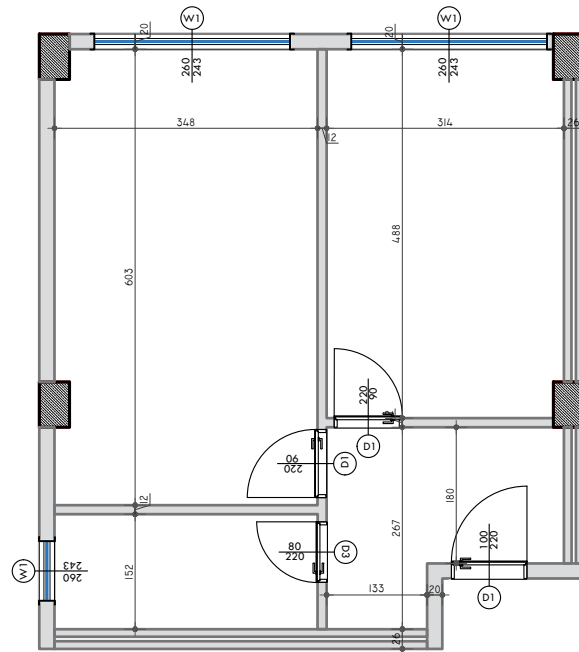

PLANIMETRIA E APARTAMENTIT - PERMASIM

SHKALLA 1:100

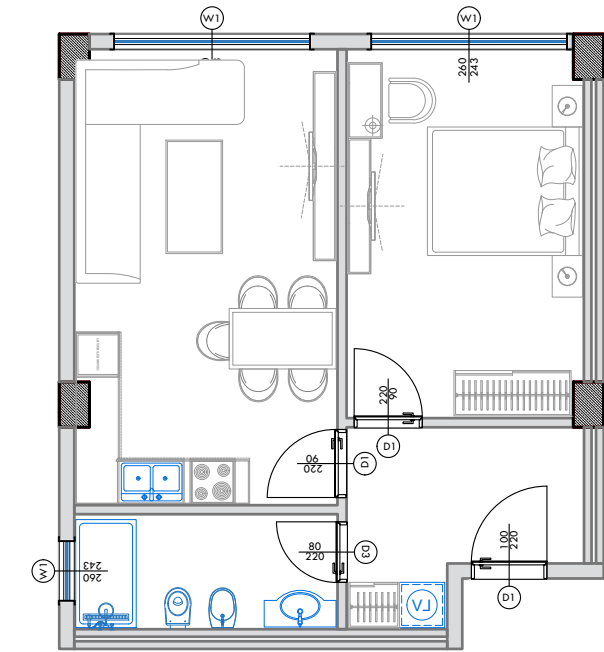

PLANIMETRIA E APARTAMENTIT - MOBILIM

SHKALLA 1:100

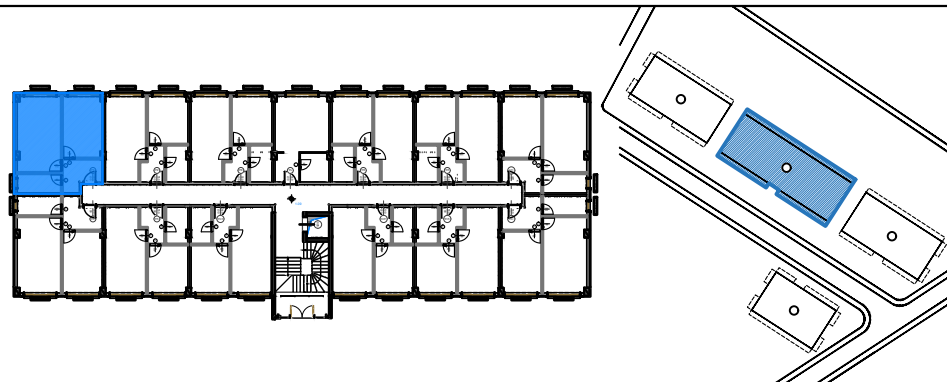

POZICIONI I APARTAMENTIT NE PLANIMETRINE E KATIT



POZICIONI I APARTAMENTIT NE ALTIMETRI - FASADA VERIORE



PAMJE 3 DIMENSIONALE E APARTAMENTIT

NR.1



PAMJE 3 DIMENSIONALE E APARTAMENTIT

NR.2

“4 GODINA BANIMI DHE SHËRBIMI 5 KATE DHE 1 KAT PARKIM NËNTOKË”
Adresa: Pavarsia e Kosovës, Golem - Bashkia Kavajë

INVESTITOR DHE SUBJEKT NDERTUES:

"LOREDIS" Sh.p.k
NIPT: M32202503U
Kavajë / Albania
Tel: +355694080880

PROJEKTUES:

VAEKU STUDIO
NIPT: M11319016N
Adresa: "Kompleksi Magnet",
Njësia Lyra 2018_1
Njësia Administrative Nr.7
Tiranë/Albania
E-mail: u.hoxha@vaeku.studio
Tel: +355674088492



APARTAMENTI NR:

P11

Objekti Nr :

2

Kati :

0

Orientimi :

JUG

Siperfaqe Apartamenti :

55.2 m²

Ambjente te perbashketa:

5.9 m²

Siperfaqe totale:

61.1 m²

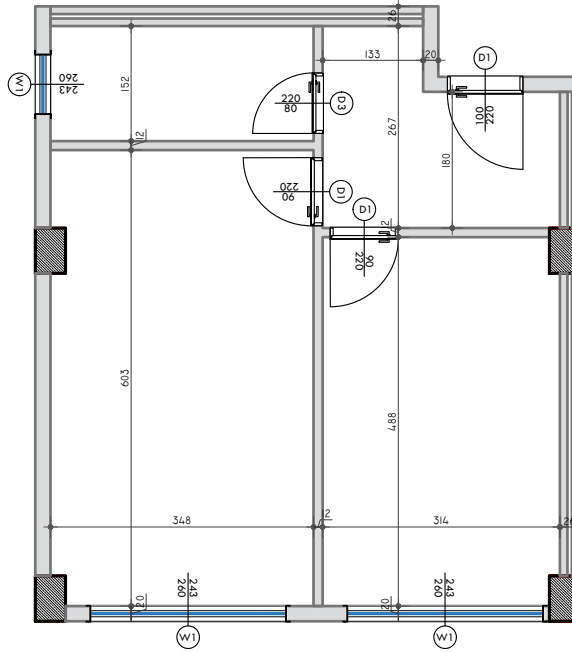

PLANIMETRIA E APARTAMENTIT - PERMASIM

SHKALLA 1:100

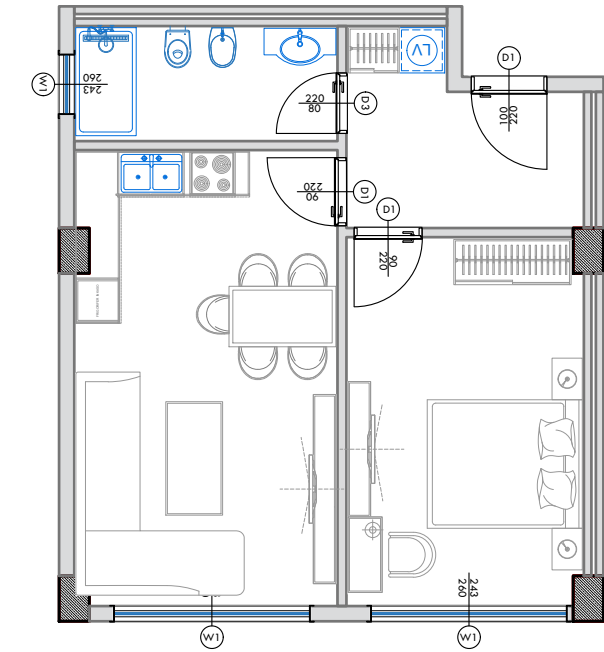

PLANIMETRIA E APARTAMENTIT - MOBILIM

SHKALLA 1:100

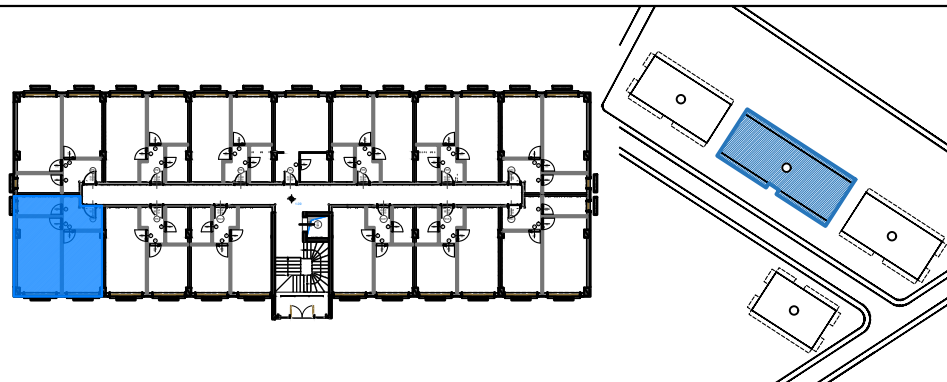

POZICIONI I APARTAMENTIT NE PLANIMETRINE E KATIT



POZICIONI I APARTAMENTIT NE ALTIMETRI - FASADA JUGORE



PAMJE 3 DIMENSIONALE E APARTAMENTIT

NR.1



PAMJE 3 DIMENSIONALE E APARTAMENTIT

NR.2

“4 GODINA BANIMI DHE SHËRBIMI 5 KATE DHE 1 KAT PARKIM NËNTOKË”
Adresa: Pavarsia e Kosovës, Golem - Bashkia Kavajë

INVESTITOR DHE SUBJEKT NDERTUES:

"LOREDIS" Sh.p.k
NIPT: M32202503U
Kavajë / Albania
Tel: +355694080880

PROJEKTUES:

VAEKU STUDIO
NIPT: M11319016N
Adresa: "Kompleksi Magnet",
Njësia Lyra 2018_1
Njësia Administrative Nr.7
Tiranë/Albania
E-mail: u.hoxha@vaeku.studio
Tel: +355674088492



APARTAMENTI NR:

P12

Objekti Nr :

2

Kati :

0

Orientimi :

JUG

Siperfaqe Apartamenti :

49.0 m²

Ambjente te perbashketa:

5.3 m²

Siperfaqe totale:

54.3 m²

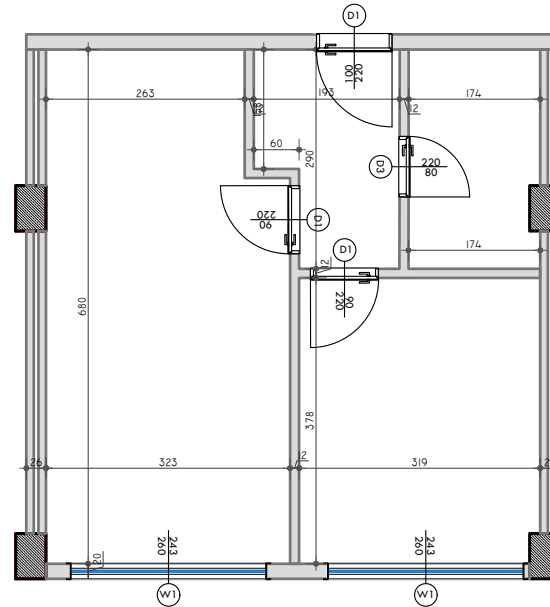

PLANIMETRIA E APARTAMENTIT - PERMASIM

SHKALLA 1:100

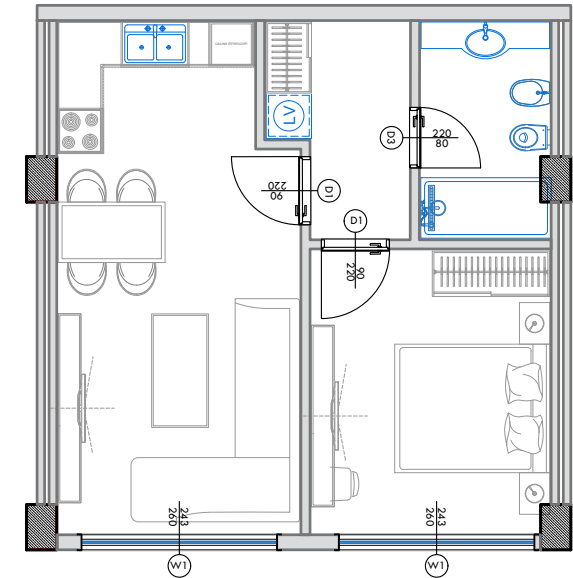

PLANIMETRIA E APARTAMENTIT - MOBILIM

SHKALLA 1:100

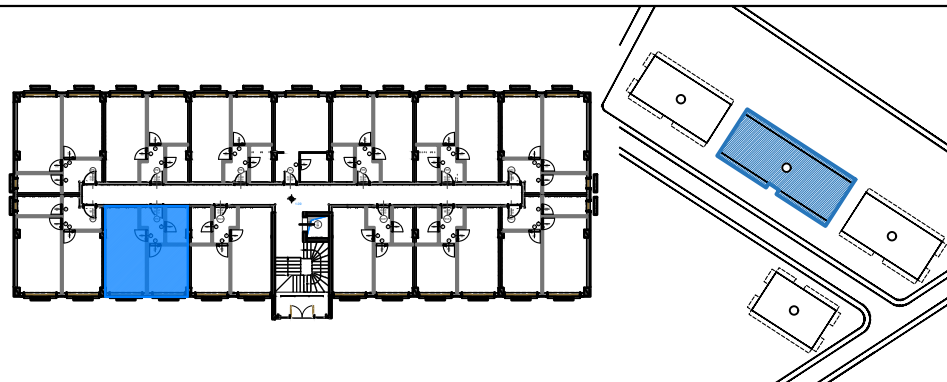

POZICIONI I APARTAMENTIT NE PLANIMETRINE E KATIT

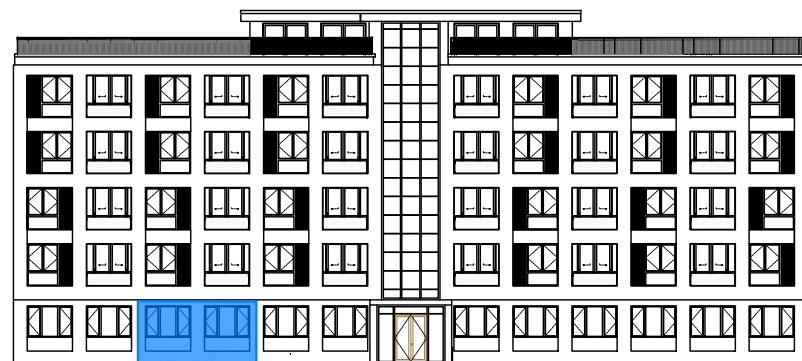

POZICIONI I APARTAMENTIT NE ALTIMETRI - FASADA JUGORE



PAMJE 3 DIMENSIONALE E APARTAMENTIT

NR.1



PAMJE 3 DIMENSIONALE E APARTAMENTIT

NR.2

“4 GODINA BANIMI DHE SHËRBIMI 5 KATE DHE 1 KAT PARKIM NËNTOKË”
Adresa: Pavarsia e Kosovës, Golem - Bashkia Kavajë

INVESTITOR DHE SUBJEKT NDERTUES:

"LOREDIS" Sh.p.k
NIPT: M32202503U
Kavajë / Albania
Tel: +355694080880

PROJEKTUES:

VAEKU STUDIO
NIPT: M11319016N
Adresa: "Kompleksi Magnet",
Njësia Lyra 2018_1
Njësia Administrative Nr.7
Tiranë/Albania
E-mail: u.hoxha@vaeku.studio
Tel: +355674088492



APARTAMENTI NR:

01

Objekti Nr :

2

Kati :

1

Orientimi :

JUG

Siperfaqe Apartamenti :

61.0 m²

Ambjente te perbashketa:

6.5 m²

Siperfaqe totale:

67.5 m²

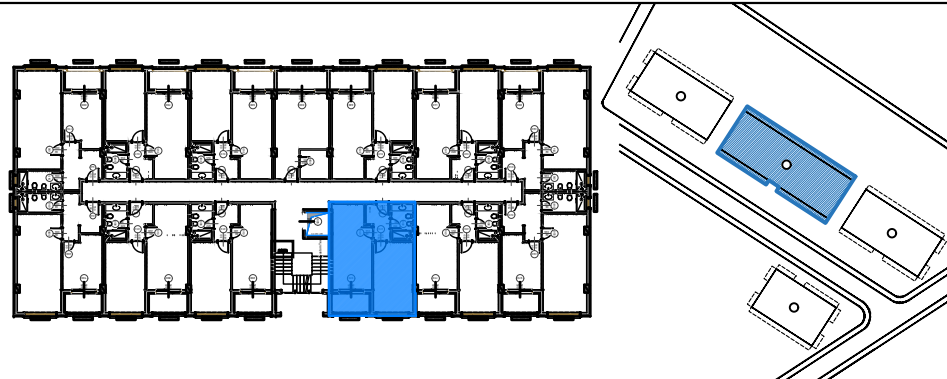
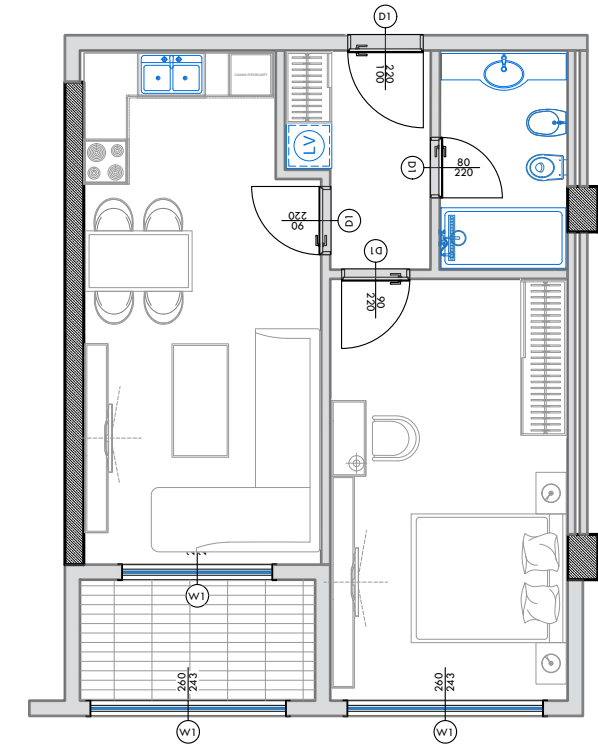
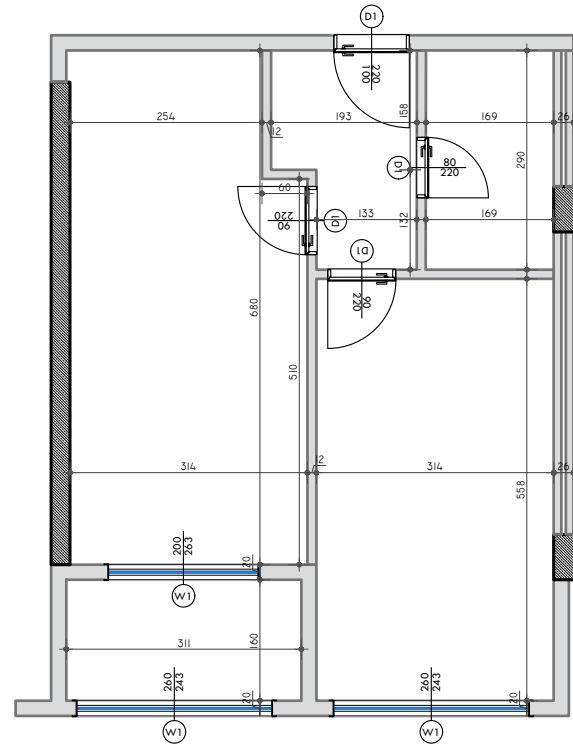

POZICIONI I APARTAMENTIT NE PLANIMETRINE E KATIT



POZICIONI I APARTAMENTIT NE ALTIMETRI - FASADA JUGORE

PLANIMETRIA E APARTAMENTIT - PERMASIM

SHKALLA 1:100

PLANIMETRIA E APARTAMENTIT - MOBILIM

SHKALLA 1:100



PAMJE 3 DIMENSIONALE E APARTAMENTIT

NR.1



PAMJE 3 DIMENSIONALE E APARTAMENTIT

NR.2

“4 GODINA BANIMI DHE SHËRBIMI 5 KATE DHE 1 KAT PARKIM NËNTOKË”
Adresa: Pavarsia e Kosovës, Golem - Bashkia Kavajë

INVESTITOR DHE SUBJEKT NDERTUES:

"LOREDIS" Sh.p.k
NIPT: M32202503U
Kavajë / Albania
Tel: +355694080880

PROJEKTUES:

VAEKU STUDIO
NIPT: M11319016N
Adresa: "Kompleksi Magnet",
Njësia Lyra 2018_1
Njësia Administrative Nr.7
Tiranë/Albania
E-mail: u.hoxha@vaeku.studio
Tel: +355674088492



APARTAMENTI NR:

02

Objekti Nr :

2

Kati :

1

Orientimi :

JUG

Siperfaqe Apartamenti :

61.0 m²

Ambjente te perbashketa:

6.5 m²

Siperfaqe totale:

67.5 m²

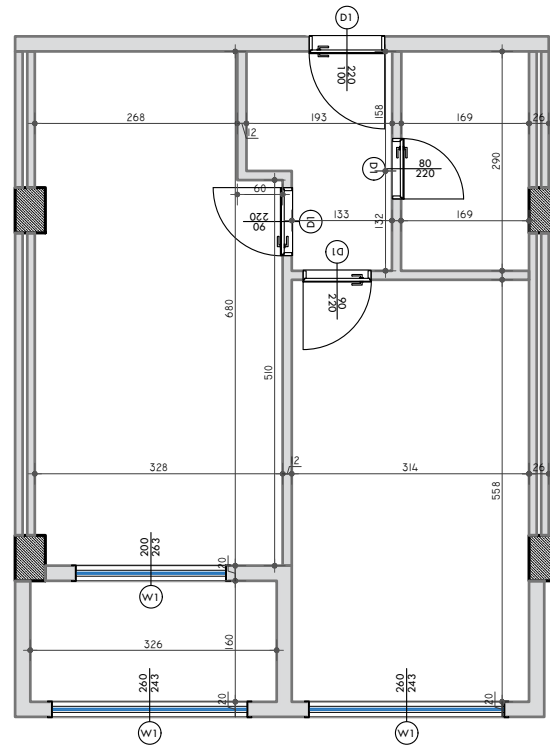

PLANIMETRIA E APARTAMENTIT - PERMASIM

SHKALLA 1:100

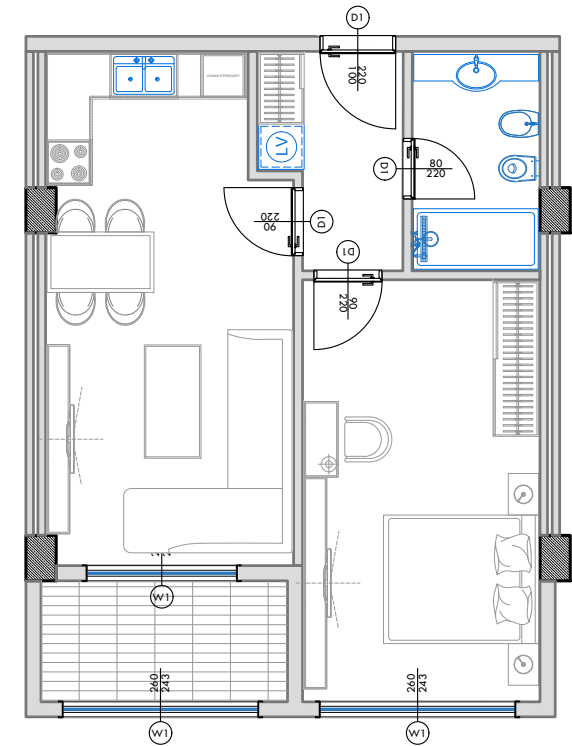

PLANIMETRIA E APARTAMENTIT - MOBILIM

SHKALLA 1:100

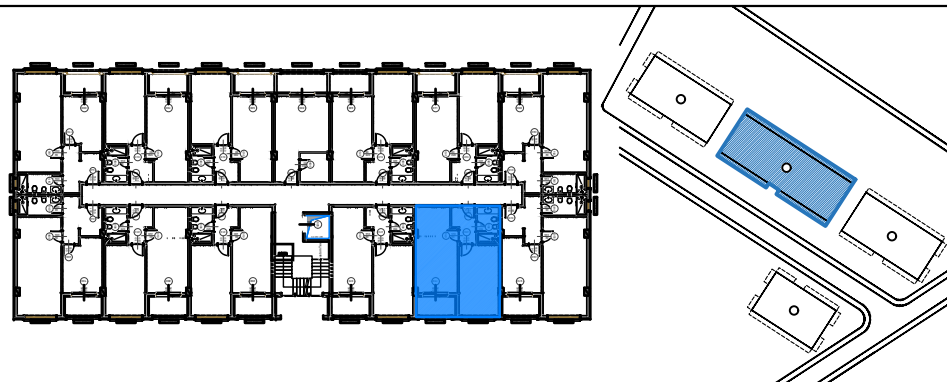

POZICIONI I APARTAMENTIT NE PLANIMETRINE E KATIT



POZICIONI I APARTAMENTIT NE ALTIMETRI - FASADA JUGORE



PAMJE 3 DIMENSIONALE E APARTAMENTIT

NR.1



PAMJE 3 DIMENSIONALE E APARTAMENTIT

NR.2

“4 GODINA BANIMI DHE SHËRBIMI 5 KATE DHE 1 KAT PARKIM NËNTOKË”
Adresa: Pavarsia e Kosovës, Golem - Bashkia Kavajë

INVESTITOR DHE SUBJEKT NDERTUES:

"LOREDIS" Sh.p.k
NIPT: M32202503U
Kavajë / Albania
Tel: +355694080880

PROJEKTUES:

VAEKU STUDIO
NIPT: M11319016N
Adresa: "Kompleksi Magnet",
Njësia Lyra 2018_1
Njësia Administrative Nr.7
Tiranë/Albania
E-mail: u.hoxha@vaeku.studio
Tel: +355674088492



APARTAMENTI NR:

03

Objekti Nr :

2

Kati :

1

Orientimi :

JUG

Siperfaqe Apartamenti :

67.4 m²

Ambjente te perbashketa:

7.2 m²

Siperfaqe totale:

74.6 m²

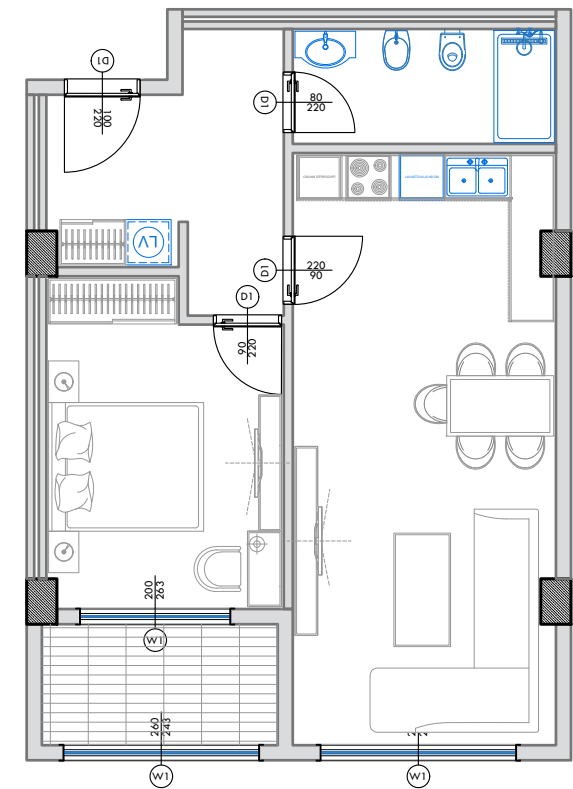
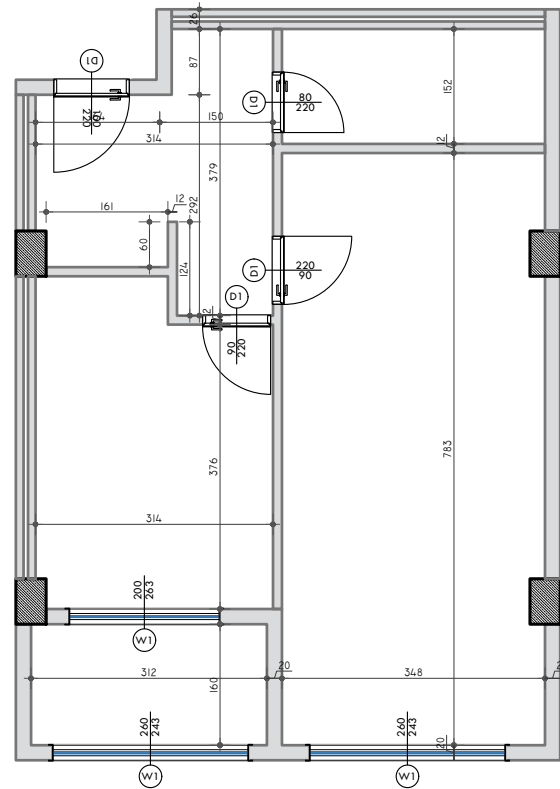

PLANIMETRIA E APARTAMENTIT - PERMASIM

SHKALLA 1:100

PLANIMETRIA E APARTAMENTIT - MOBILIM

SHKALLA 1:100

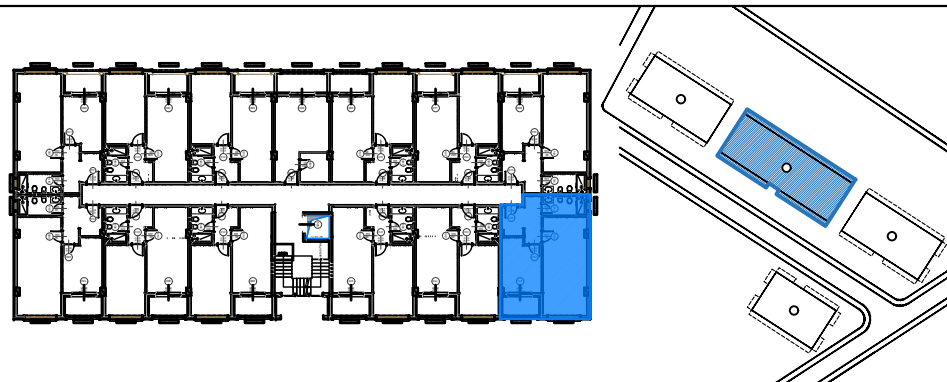

POZICIONI I APARTAMENTIT NE PLANIMETRINE E KATIT



PAMJE 3 DIMENSIONALE E APARTAMENTIT

NR.1



PAMJE 3 DIMENSIONALE E APARTAMENTIT

NR.2



POZICIONI I APARTAMENTIT NE ALTIMETRI - FASADA JUGORE

“4 GODINA BANIMI DHE SHËRBIMI 5 KATE DHE 1 KAT PARKIM NËNTOKË”
Adresa: Pavarsia e Kosovës, Golem - Bashkia Kavajë

INVESTITOR DHE SUBJEKT NDERTUES:

"LOREDIS" Sh.p.k
NIPT: M32202503U
Kavajë / Albania
Tel: +355694080880

PROJEKTUES:

VAEKU STUDIO
NIPT: M11319016N
Adresa: "Kompleksi Magnet",
Njësia Lyra 2018_1
Njësia Administrative Nr.7
Tiranë/Albania
E-mail: u.hoxha@vaeku.studio
Tel: +355674088492



APARTAMENTI NR:

04

Objekti Nr :

2

Kati :

1

Orientimi :

VERI

Siperfaqe Apartamenti :

67.4 m²

Ambjente te perbashketa:

7.2 m²

Siperfaqe totale:

74.6 m²

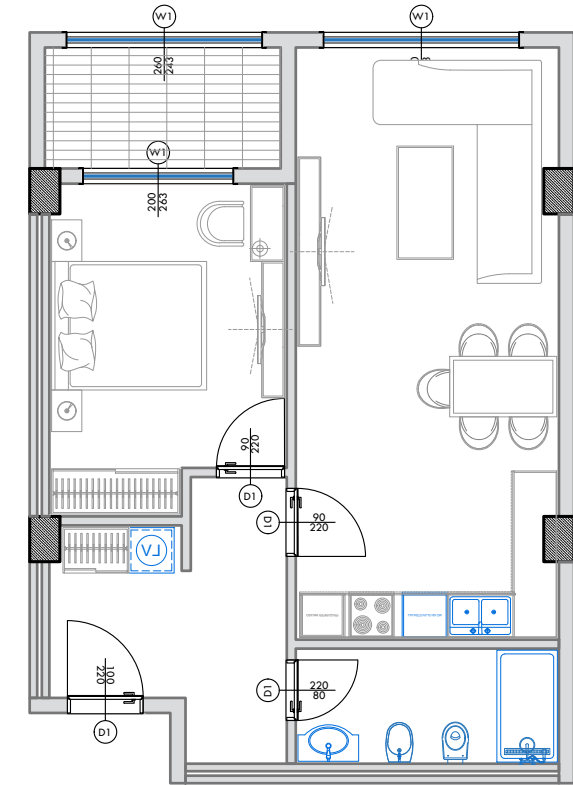
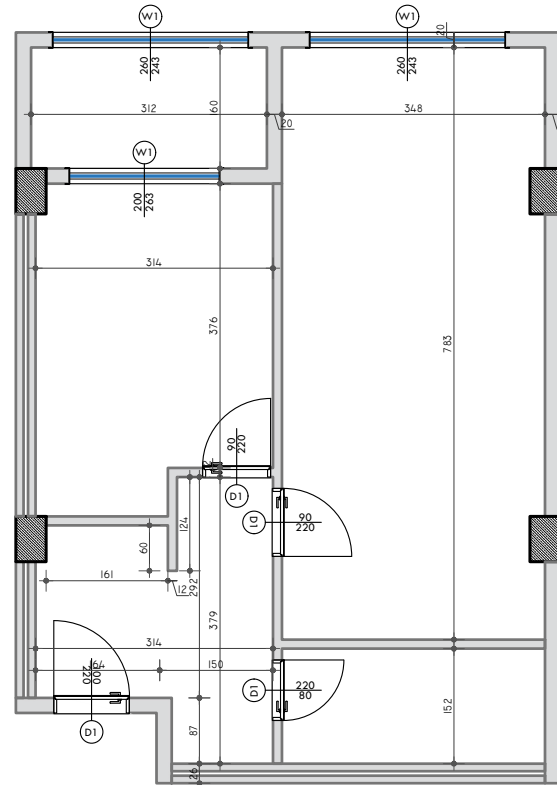

PLANIMETRIA E APARTAMENTIT - PERMASIM

SHKALLA 1:100

PLANIMETRIA E APARTAMENTIT - MOBILIM

SHKALLA 1:100

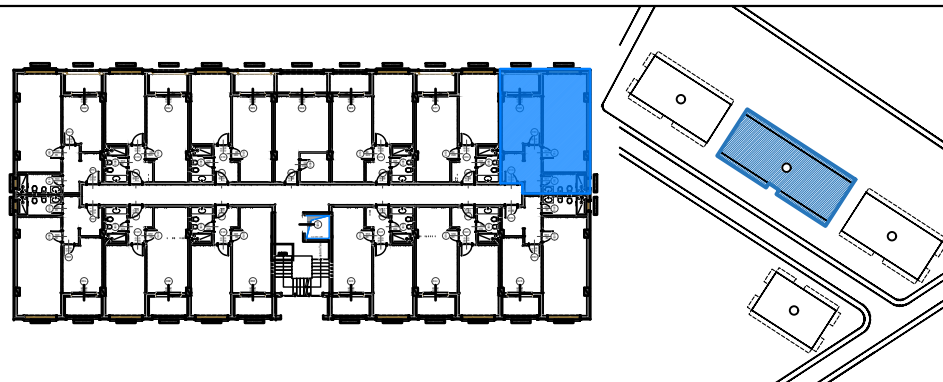

POZICIONI I APARTAMENTIT NE PLANIMETRINE E KATIT



PAMJE 3 DIMENSIONALE E APARTAMENTIT

NR.1



PAMJE 3 DIMENSIONALE E APARTAMENTIT

NR.2



POZICIONI I APARTAMENTIT NE ALTIMETRI - FASADA VERIORE

“4 GODINA BANIMI DHE SHËRBIMI 5 KATE DHE 1 KAT PARKIM NËNTOKË”
Adresa: Pavarsia e Kosovës, Golem - Bashkia Kavajë

INVESTITOR DHE SUBJEKT NDERTUES:

"LOREDIS" Sh.p.k
NIPT: M32202503U
Kavajë / Albania
Tel: +355694080880

PROJEKTUES:

VAEKU STUDIO
NIPT: M11319016N
Adresa: "Kompleksi Magnet",
Njësia Lyra 2018_1
Njësia Administrative Nr.7
Tiranë/Albania
E-mail: u.hoxha@vaeku.studio
Tel: +355674088492



APARTAMENTI NR:

05

Objekti Nr :

2

Kati :

1

Orientimi :

VERI

Siperfaqe Apartamenti :

61.0 m²

Ambjente te perbashketa:

6.5 m²

Siperfaqe totale:

67.5 m²

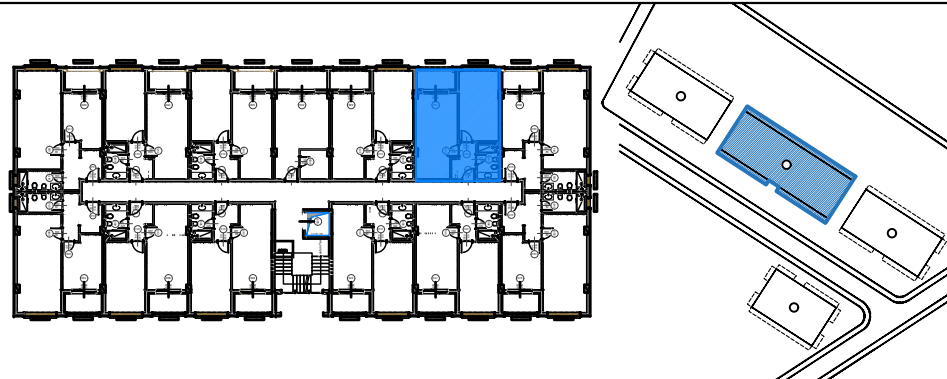
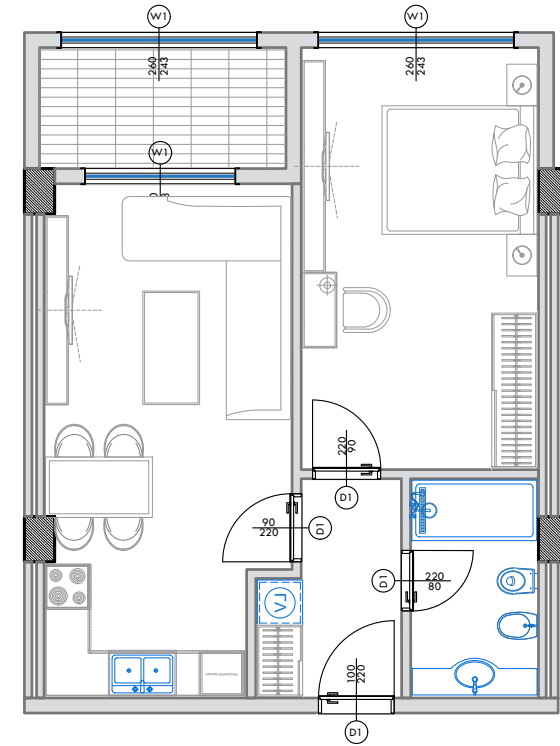
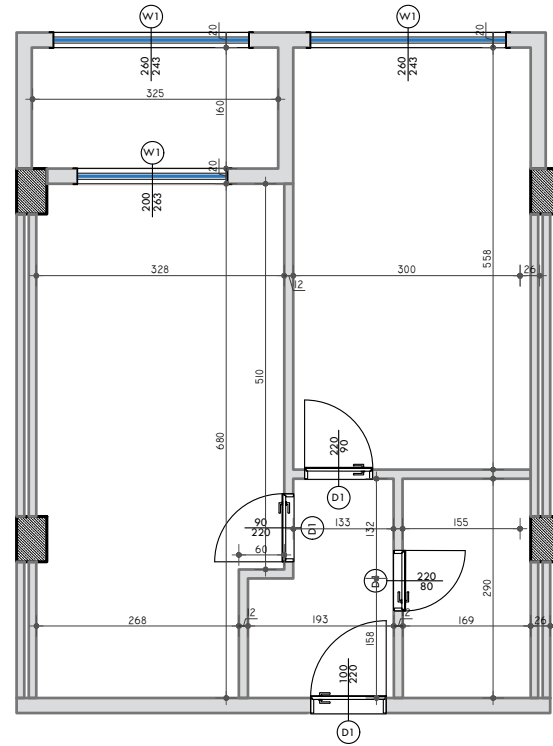

POZICIONI I APARTAMENTIT NE PLANIMETRINE E KATIT



POZICIONI I APARTAMENTIT NE ALTIMETRI - FASADA VERIORE

PLANIMETRIA E APARTAMENTIT - PERMASIM

SHKALLA 1:100

PLANIMETRIA E APARTAMENTIT - MOBILIM

SHKALLA 1:100



PAMJE 3 DIMENSIONALE E APARTAMENTIT

NR.1



PAMJE 3 DIMENSIONALE E APARTAMENTIT

NR.2

“4 GODINA BANIMI DHE SHËRBIMI 5 KATE DHE 1 KAT PARKIM NËNTOKË”
Adresa: Pavarsia e Kosovës, Golem - Bashkia Kavajë

INVESTITOR DHE SUBJEKT NDERTUES:

"LOREDIS" Sh.p.k
NIPT: M32202503U
Kavajë / Albania
Tel: +355694080880

PROJEKTUES:

VAEKU STUDIO
NIPT: M11319016N
Adresa: "Kompleksi Magnet",
Njësia Lyra 2018_1
Njësia Administrative Nr.7
Tiranë/Albania
E-mail: u.hoxha@vaeku.studio
Tel: +355674088492



APARTAMENTI NR:

06

Objekti Nr :

2

Kati :

1

Orientimi :

VERI

Siperfaqe Apartamenti :

61.0 m²

Ambjente te perbashketa:

6.5 m²

Siperfaqe totale:

67.5 m²

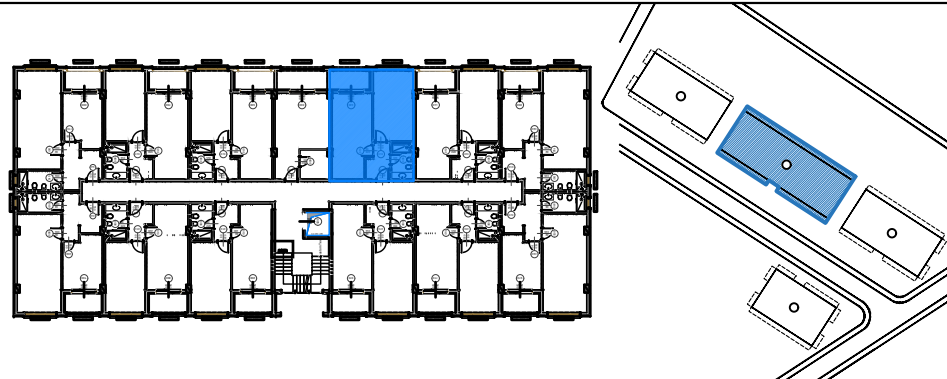
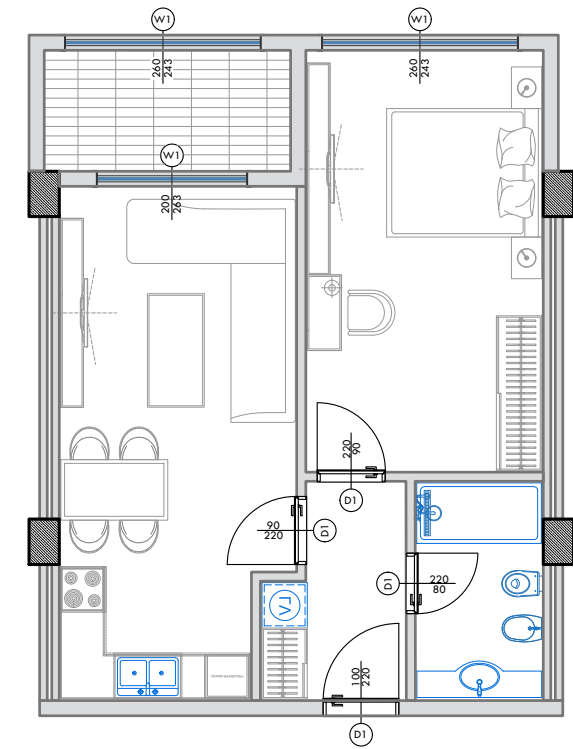
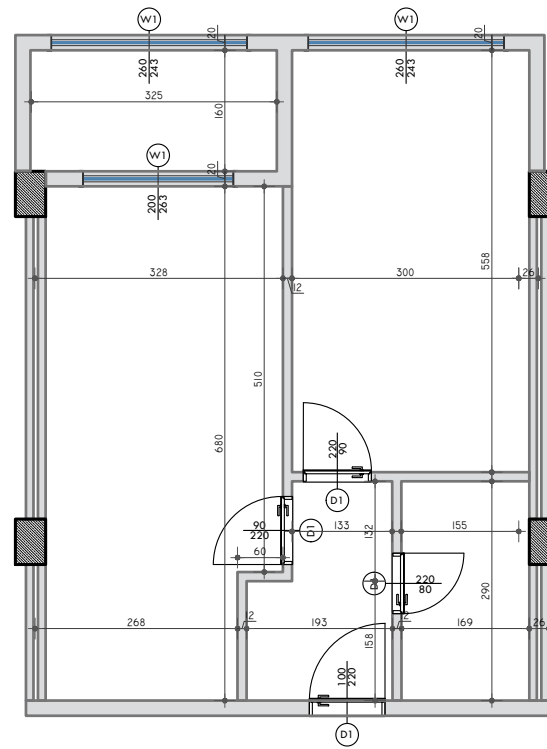

POZICIONI I APARTAMENTIT NE PLANIMETRINE E KATIT



POZICIONI I APARTAMENTIT NE ALTIMETRI - FASADA VERIORE

PLANIMETRIA E APARTAMENTIT - PERMASIM

SHKALLA 1:100

PLANIMETRIA E APARTAMENTIT - MOBILIM

SHKALLA 1:100



PAMJE 3 DIMENSIONALE E APARTAMENTIT

NR.1

PAMJE 3 DIMENSIONALE E APARTAMENTIT

NR.2

“4 GODINA BANIMI DHE SHËRBIMI 5 KATE DHE 1 KAT PARKIM NËNTOKË”
Adresa: Pavarsia e Kosovës, Golem - Bashkia Kavajë

INVESTITOR DHE SUBJEKT NDERTUES:

"LOREDIS" Sh.p.k
NIPT: M32202503U
Kavajë / Albania
Tel: +355694080880

PROJEKTUES:

VAEKU STUDIO
NIPT: M11319016N
Adresa: "Kompleksi Magnet",
Njësia Lyra 2018_1
Njësia Administrative Nr.7
Tiranë/Albania
E-mail: u.hoxha@vaeku.studio
Tel: +355674088492



APARTAMENTI NR:

08

Objekti Nr :

2

Kati :

1

Orientimi :

VERI

Siperfaqe Apartamenti :

61.0 m²

Ambjente te perbashketa:

6.5 m²

Siperfaqe totale:

67.5 m²

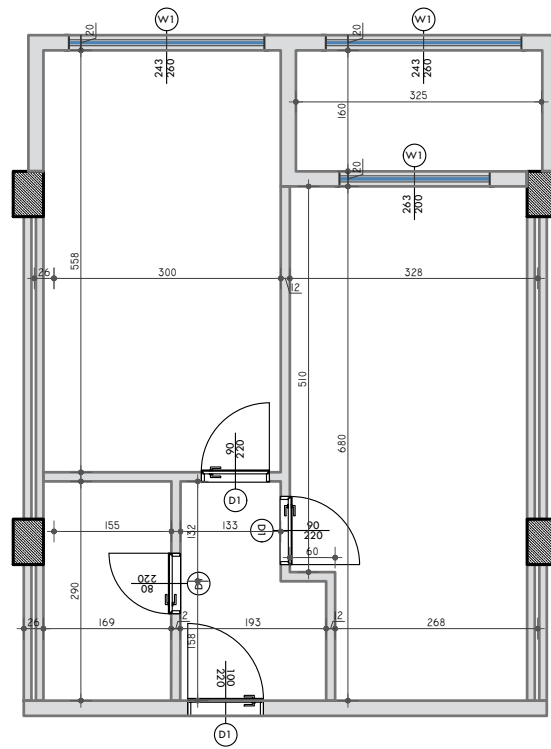

PLANIMETRIA E APARTAMENTIT - PERMASIM

SHKALLA 1:100

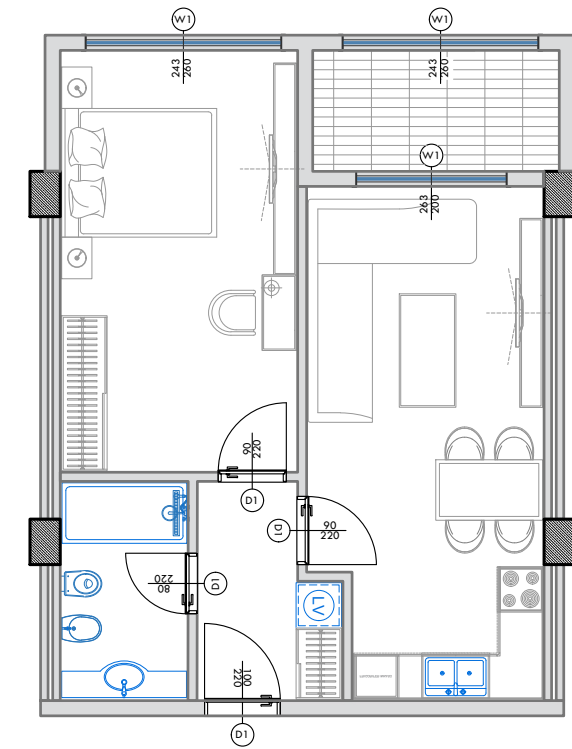

PLANIMETRIA E APARTAMENTIT - MOBILIM

SHKALLA 1:100

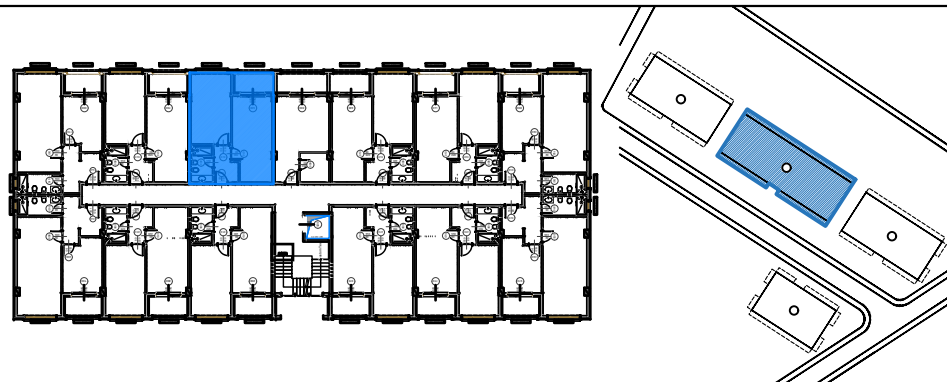

POZICIONI I APARTAMENTIT NE PLANIMETRINE E KATIT



POZICIONI I APARTAMENTIT NE ALTIMETRI - FASADA VERIORE



PAMJE 3 DIMENSIONALE E APARTAMENTIT

NR.1



PAMJE 3 DIMENSIONALE E APARTAMENTIT

NR.2

“4 GODINA BANIMI DHE SHËRBIMI 5 KATE DHE 1 KAT PARKIM NËNTOKË”
Adresa: Pavarsia e Kosovës, Golem - Bashkia Kavajë

INVESTITOR DHE SUBJEKT NDERTUES:

"LOREDIS" Sh.p.k
NIPT: M32202503U
Kavajë / Albania
Tel: +355694080880

PROJEKTUES:

VAEKU STUDIO
NIPT: M11319016N
Adresa: "Kompleksi Magnet",
Njësia Lyra 2018_1
Njësia Administrative Nr.7
Tiranë/Albania
E-mail: u.hoxha@vaeku.studio
Tel: +355674088492



P.T

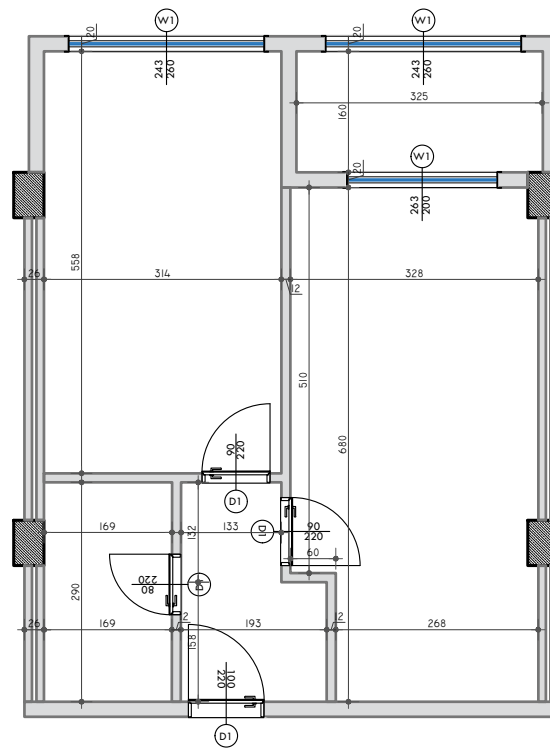

PLANIMETRIA E APARTAMENTIT - PERMASIM

SHKALLA 1:100

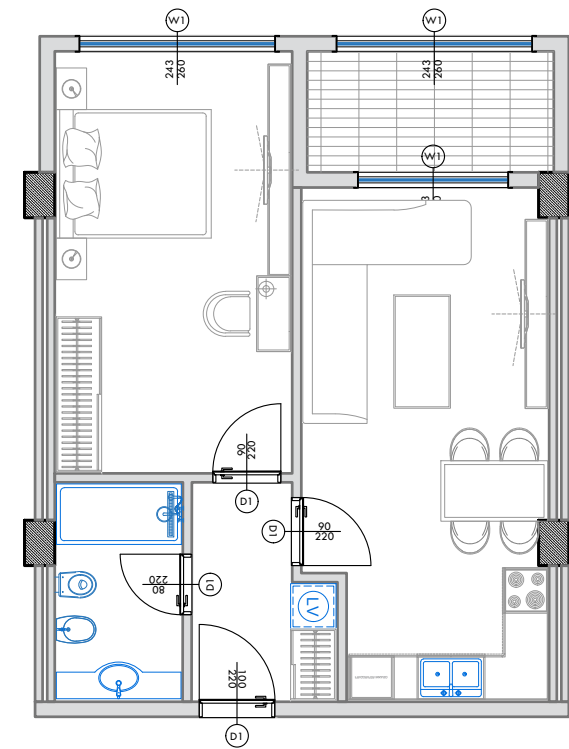

PLANIMETRIA E APARTAMENTIT - MOBILIM

SHKALLA 1:100

APARTAMENTI NR:	09
Objekti Nr :	2
Kati :	1
Orientimi :	VERI
Siperfaqe Apartamenti :	61.0 m ²
Ambjente te perbashketa:	6.5 m ²
Siperfaqe totale:	67.5 m ²

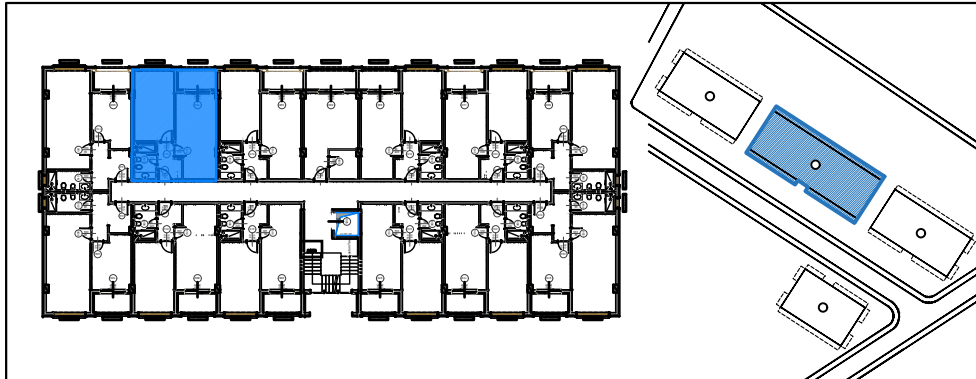

POZICIONI I APARTAMENTIT NE PLANIMETRINE E KATIT



POZICIONI I APARTAMENTIT NE ALTIMETRI - FASADA VERIORE



PAMJE 3 DIMENSIONALE E APARTAMENTIT

NR.1



PAMJE 3 DIMENSIONALE E APARTAMENTIT

NR.2

“4 GODINA BANIMI DHE SHËRBIMI 5 KATE DHE 1 KAT PARKIM NËNTOKË”
Adresa: Pavarsia e Kosovës, Golem - Bashkia Kavajë

INVESTITOR DHE SUBJEKT NDERTUES:

"LOREDIS" Sh.p.k
NIPT: M32202503U
Kavajë / Albania
Tel: +355694080880

PROJEKTUES:

VAEKU STUDIO
NIPT: M11319016N
Adresa: "Kompleksi Magnet",
Njësia Lyra 2018_1
Njësia Administrative Nr.7
Tiranë/Albania
E-mail: u.hoxha@vaeku.studio
Tel: +355674088492



APARTAMENTI NR:

10

Objekti Nr :

2

Kati :

1

Orientimi :

VERI

Siperfaqe Apartamenti :

67.4 m²

Ambjente te perbashketa:

7.2 m²

Siperfaqe totale:

74.6 m²



P.T

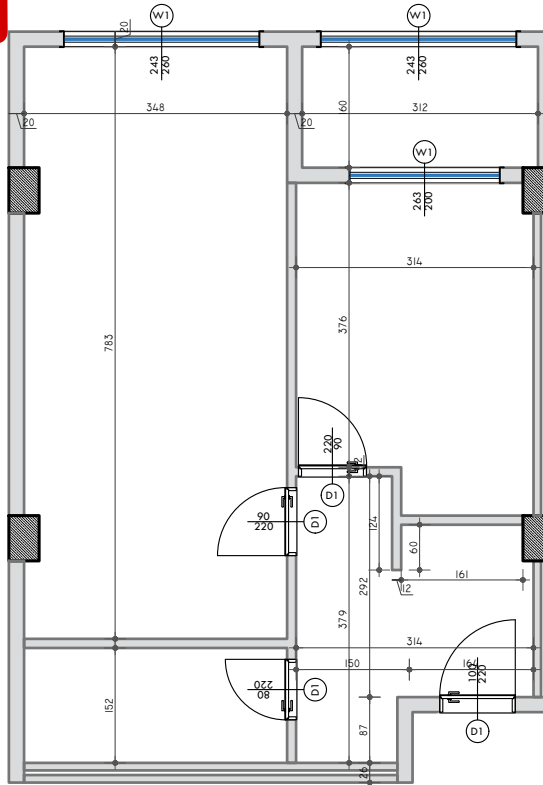

PLANIMETRIA E APARTAMENTIT - PERMASIM

SHKALLA 1:100

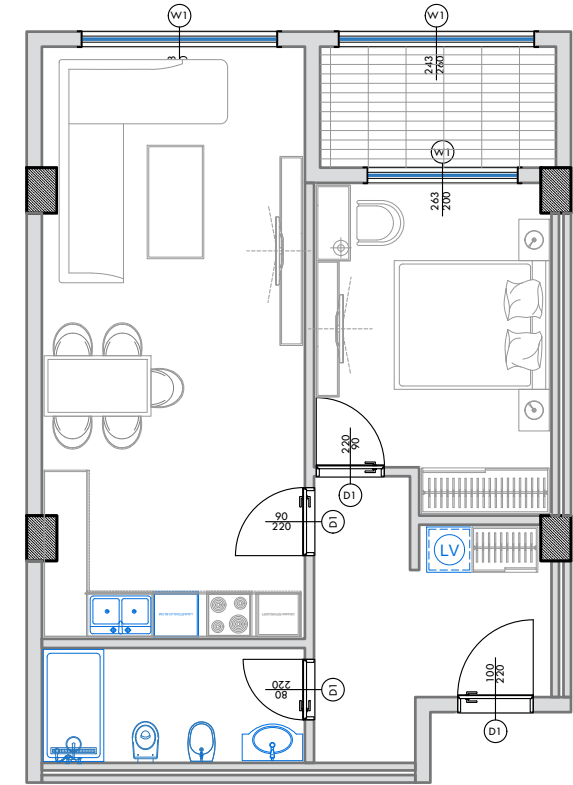

PLANIMETRIA E APARTAMENTIT - MOBILIM

SHKALLA 1:100

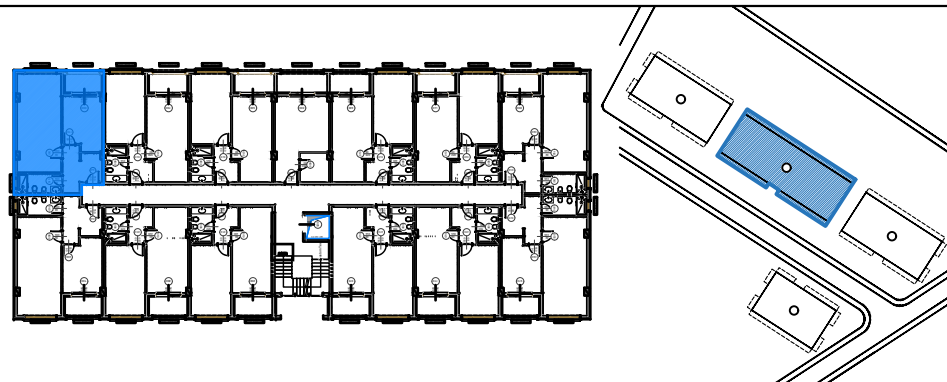

POZICIONI I APARTAMENTIT NE PLANIMETRINE E KATIT



PAMJE 3 DIMENSIONALE E APARTAMENTIT

NR.1



PAMJE 3 DIMENSIONALE E APARTAMENTIT

NR.2



POZICIONI I APARTAMENTIT NE ALTIMETRI - FASADA VERIORE

“4 GODINA BANIMI DHE SHËRBIMI 5 KATE DHE 1 KAT PARKIM NËNTOKË”
Adresa: Pavarsia e Kosovës, Golem - Bashkia Kavajë

INVESTITOR DHE SUBJEKT NDERTUES:

"LOREDIS" Sh.p.k
NIPT: M32202503U
Kavajë / Albania
Tel: +355694080880

PROJEKTUES:

VAEKU STUDIO
NIPT: M11319016N
Adresa: "Kompleksi Magnet",
Njësia Lyra 2018_1
Njësia Administrative Nr.7
Tiranë/Albania
E-mail: u.hoxha@vaeku.studio
Tel: +355674088492



APARTAMENTI NR:

11

Objekti Nr :

2

Kati :

1

Orientimi :

JUG

Siperfaqe Apartamenti :

67.4 m²

Ambjente te perbashketa:

7.2 m²

Siperfaqe totale:

74.6 m²



P.T

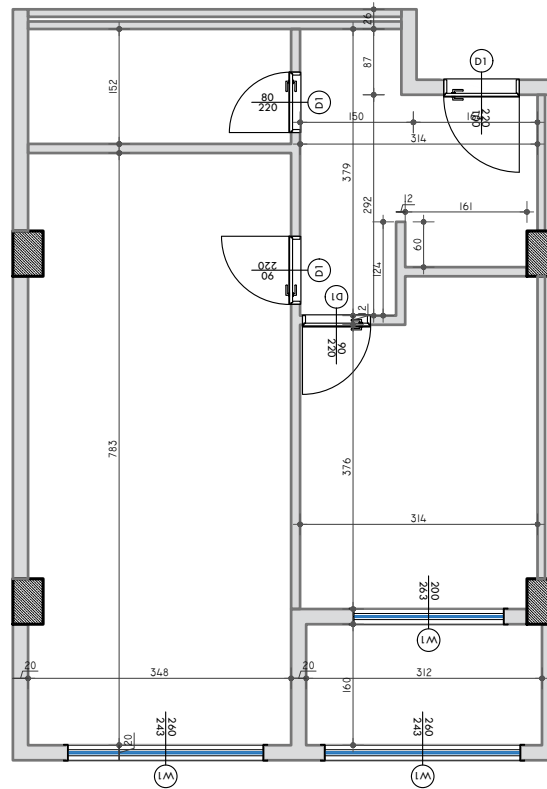

PLANIMETRIA E APARTAMENTIT - PERMASIM

SHKALLA 1:100

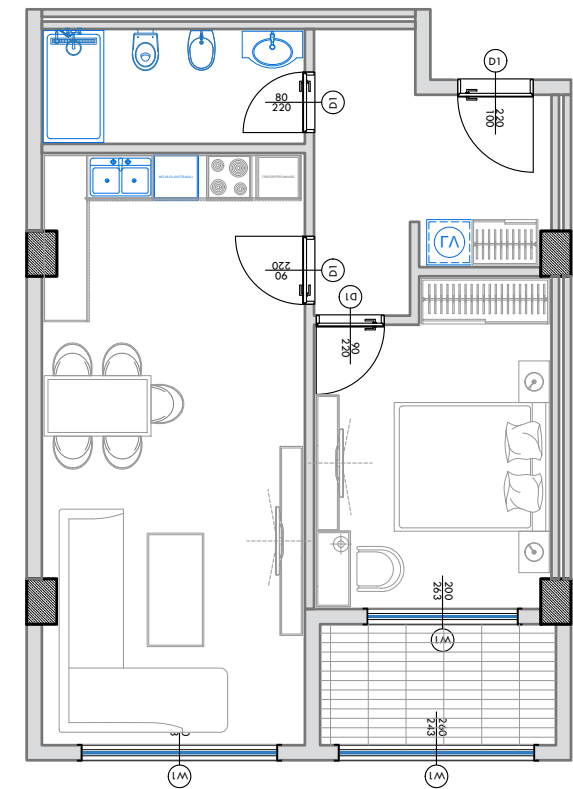

PLANIMETRIA E APARTAMENTIT - MOBILIM

SHKALLA 1:100

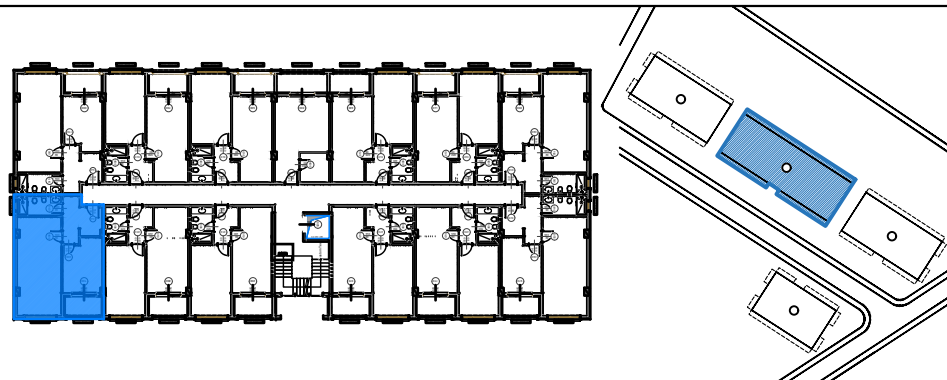

POZICIONI I APARTAMENTIT NE PLANIMETRINE E KATIT



PAMJE 3 DIMENSIONALE E APARTAMENTIT

NR.1



PAMJE 3 DIMENSIONALE E APARTAMENTIT

NR.2



POZICIONI I APARTAMENTIT NE ALTIMETRI - FASADA JUGORE

“4 GODINA BANIMI DHE SHËRBIMI 5 KATE DHE 1 KAT PARKIM NËNTOKË”
Adresa: Pavarsia e Kosovës, Golem - Bashkia Kavajë

INVESTITOR DHE SUBJEKT NDERTUES:

"LOREDIS" Sh.p.k
NIPT: M32202503U
Kavajë / Albania
Tel: +355694080880

PROJEKTUES:

VAEKU STUDIO
NIPT: M11319016N
Adresa: "Kompleksi Magnet",
Njësia Lyra 2018_1
Njësia Administrative Nr.7
Tiranë/Albania
E-mail: u.hoxha@vaeku.studio
Tel: +355674088492



P.T

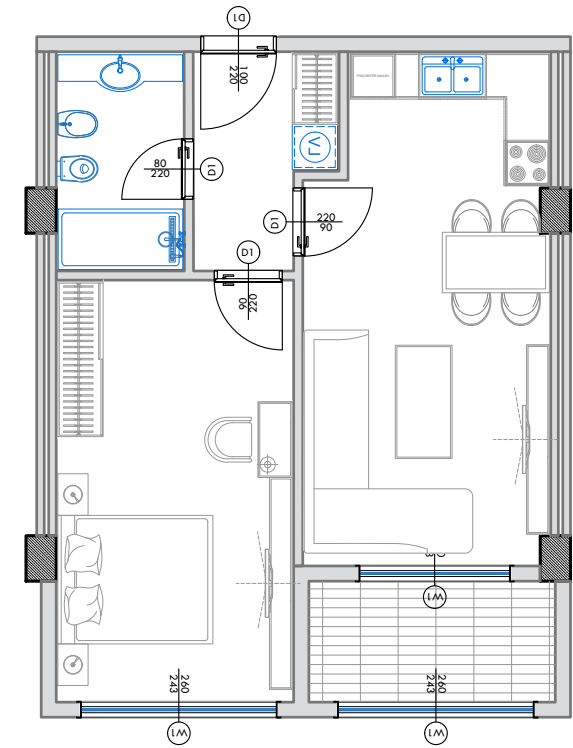
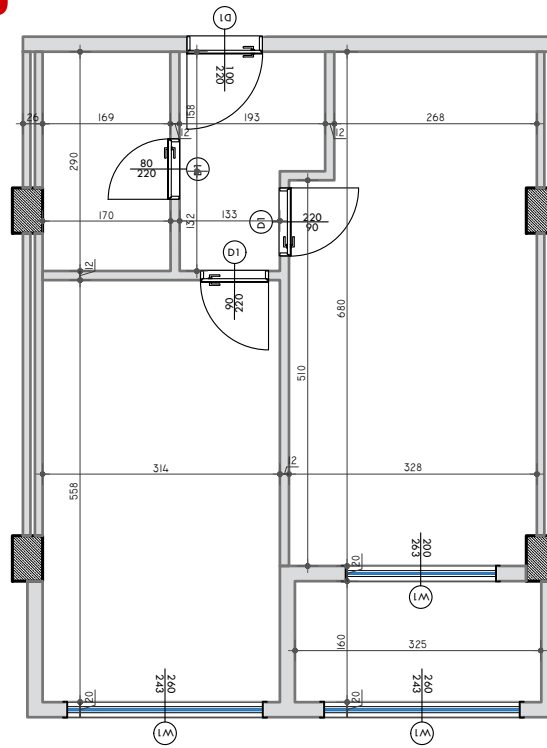

PLANIMETRIA E APARTAMENTIT - PERMASIM

SHKALLA 1:100

PLANIMETRIA E APARTAMENTIT - MOBILIM

SHKALLA 1:100

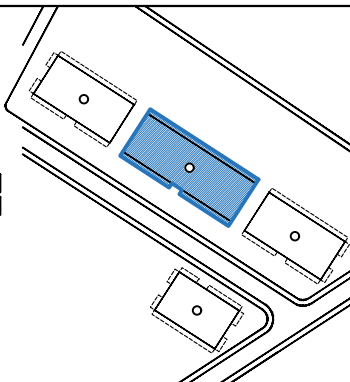

POZICIONI I APARTAMENTIT NE PLANIMETRINE E KATIT



POZICIONI I APARTAMENTIT NE ALTIMETRI - FASADA JUGORE



PAMJE 3 DIMENSIONALE E APARTAMENTIT

NR.1



PAMJE 3 DIMENSIONALE E APARTAMENTIT

NR.2

“4 GODINA BANIMI DHE SHËRBIMI 5 KATE DHE 1 KAT PARKIM NËNTOKË”
Adresa: Pavarsia e Kosovës, Golem - Bashkia Kavajë

INVESTITOR DHE SUBJEKT NDERTUES:

"LOREDIS" Sh.p.k
NIPT: M32202503U
Kavajë / Albania
Tel: +355694080880

PROJEKTUES:

VAEKU STUDIO
NIPT: M11319016N
Adresa: "Kompleksi Magnet",
Njësia Lyra 2018_1
Njësia Administrative Nr.7
Tiranë/Albania
E-mail: u.hoxha@vaeku.studio
Tel: +355674088492



P.T

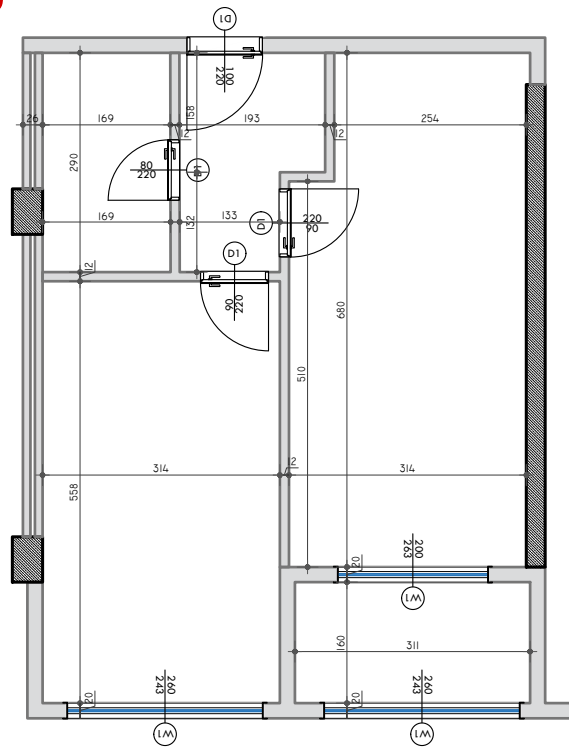

PLANIMETRIA E APARTAMENTIT - PERMASIM

SHKALLA 1:100

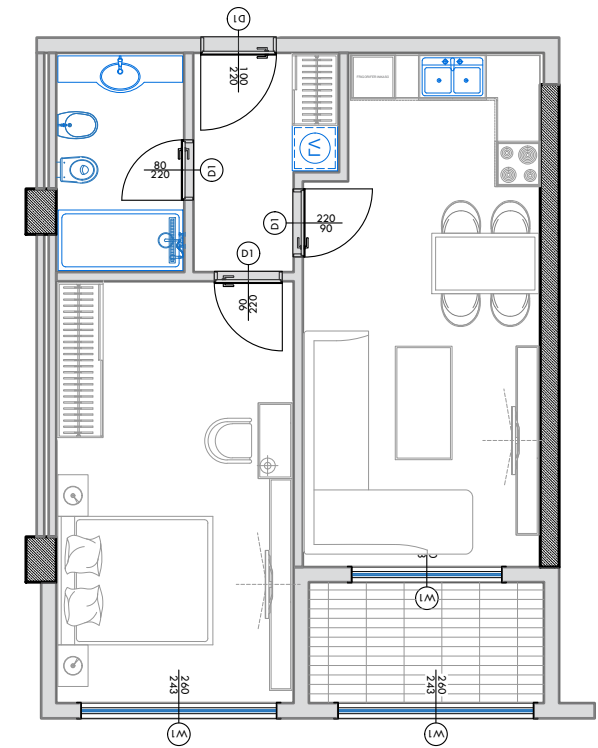

PLANIMETRIA E APARTAMENTIT - MOBILIM

SHKALLA 1:100

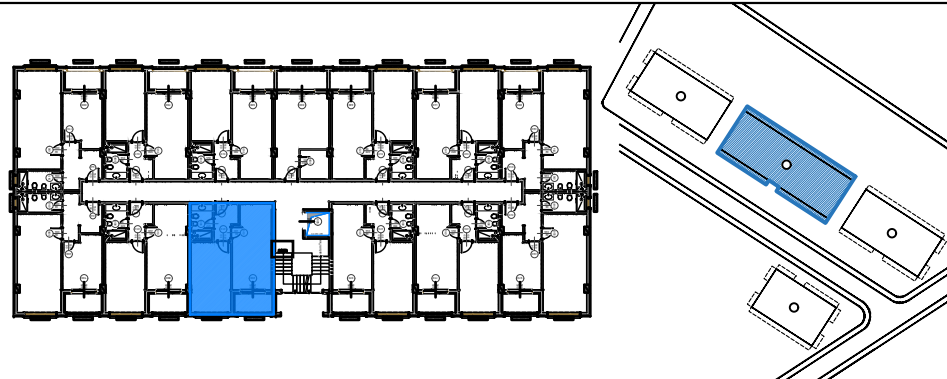

POZICIONI I APARTAMENTIT NE PLANIMETRINE E KATIT



POZICIONI I APARTAMENTIT NE ALTIMETRI - FASADA JUGORE



PAMJE 3 DIMENSIONALE E APARTAMENTIT

NR.1



PAMJE 3 DIMENSIONALE E APARTAMENTIT

NR.2

“4 GODINA BANIMI DHE SHËRBIMI 5 KATE DHE 1 KAT PARKIM NËNTOKË”
Adresa: Pavarsia e Kosovës, Golem - Bashkia Kavajë

INVESTITOR DHE SUBJEKT NDERTUES:

"LOREDIS" Sh.p.k
NIPT: M32202503U
Kavajë / Albania
Tel: +355694080880

PROJEKTUES:

VAEKU STUDIO
NIPT: M11319016N
Adresa: "Kompleksi Magnet",
Njësia Lyra 2018_1
Njësia Administrative Nr.7
Tiranë/Albania
E-mail: u.hoxha@vaeku.studio
Tel: +355674088492



P.T

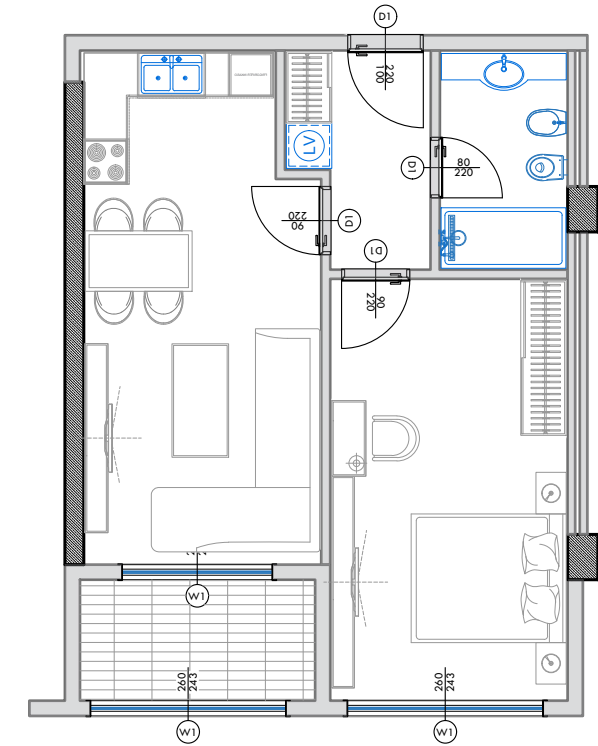
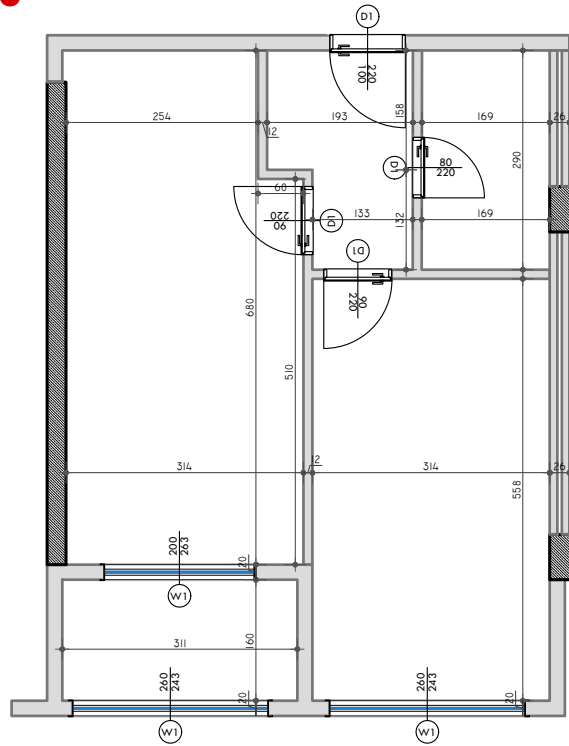

APARTAMENTI NR:	14
Objekti Nr :	2
Kati :	2
Orientimi :	JUG
Siperfaqe Apartamenti :	61.0 m ²
Ambjente te perbashketa:	6.5 m ²
Siperfaqe totale:	67.5 m ²



PLANIMETRIA E APARTAMENTIT - PERMASIM

SHKALLA 1:100

PLANIMETRIA E APARTAMENTIT - MOBILIM

SHKALLA 1:100

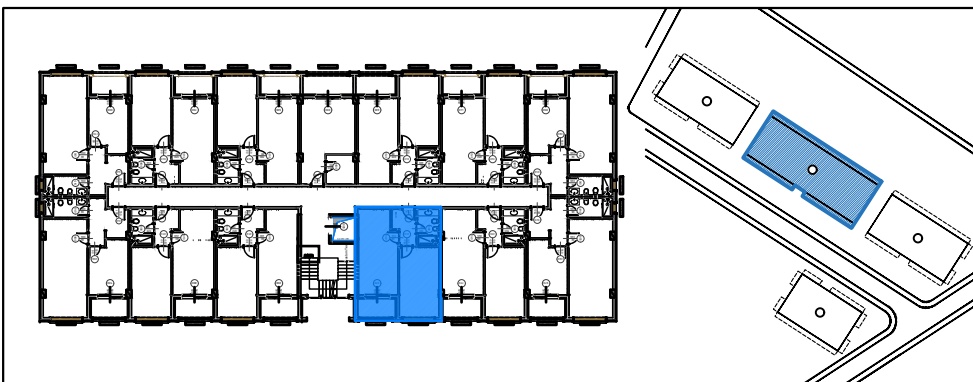

POZICIONI I APARTAMENTIT NE PLANIMETRINE E KATIT



PAMJE 3 DIMENSIONALE E APARTAMENTIT

NR.1



PAMJE 3 DIMENSIONALE E APARTAMENTIT

NR.2

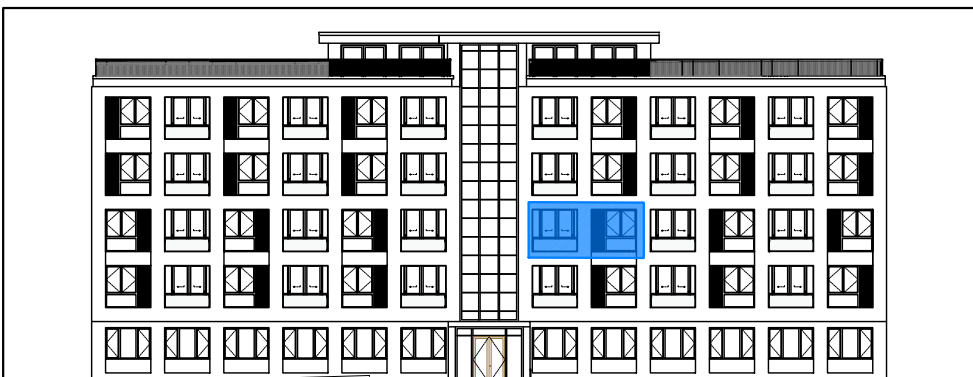

POZICIONI I APARTAMENTIT NE ALTIMETRI - FASADA JUGORE

“4 GODINA BANIMI DHE SHËRBIMI 5 KATE DHE 1 KAT PARKIM NËNTOKË”
Adresa: Pavarsia e Kosovës, Golem - Bashkia Kavajë

INVESTITOR DHE SUBJEKT NDERTUES:

"LOREDIS" Sh.p.k
NIPT: M32202503U
Kavajë / Albania
Tel: +355694080880

PROJEKTUES:

VAEKU STUDIO
NIPT: M11319016N
Adresa: "Kompleksi Magnet",
Njësia Lyra 2018_1
Njësia Administrative Nr.7
Tiranë/Albania
E-mail: u.hoxha@vaeku.studio
Tel: +355674088492



APARTAMENTI NR:

15

Objekti Nr :

2

Kati :

2

Orientimi :

JUG

Siperfaqe Apartamenti :

61.0 m²

Ambjente te perbashketa:

6.5 m²

Siperfaqe totale:

67.5 m²



P.T

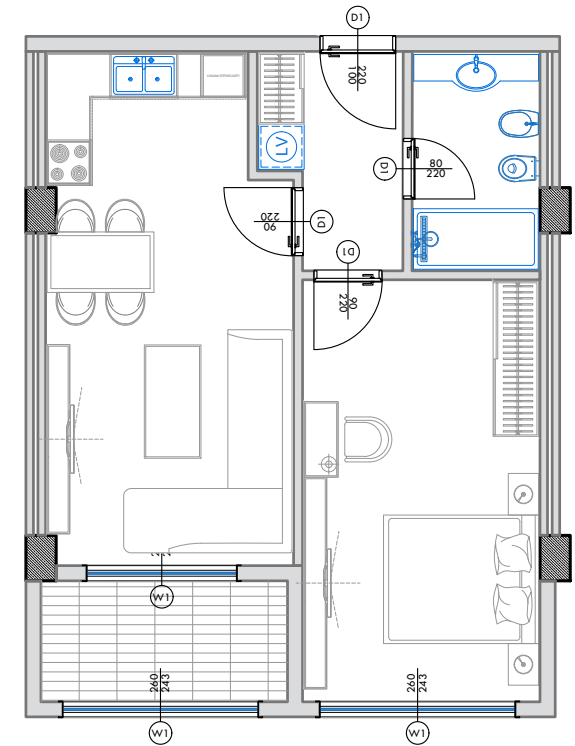
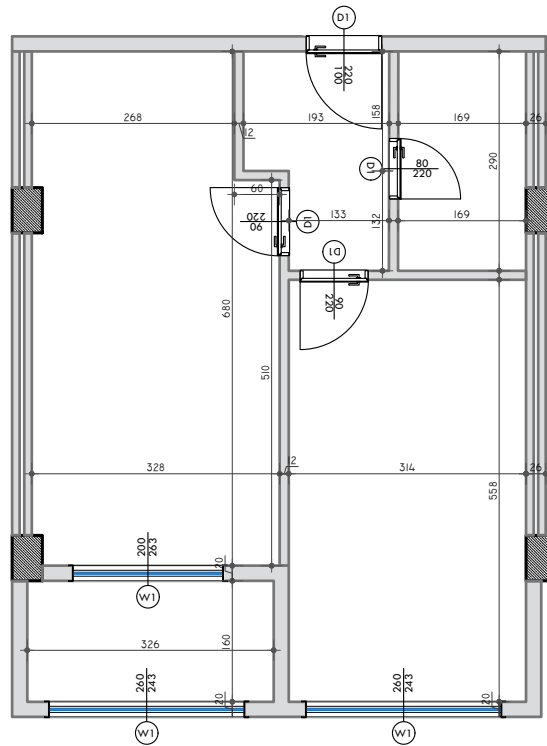

PLANIMETRIA E APARTAMENTIT - PERMASIM

SHKALLA 1:100

PLANIMETRIA E APARTAMENTIT - MOBILIM

SHKALLA 1:100

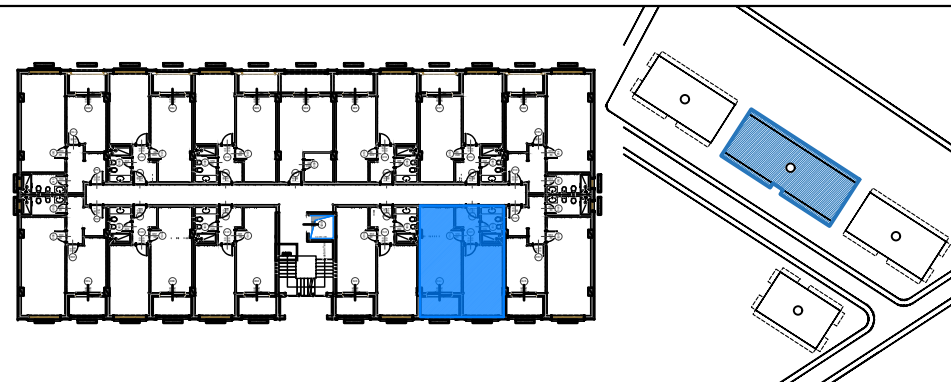

POZICIONI I APARTAMENTIT NE PLANIMETRINE E KATIT



POZICIONI I APARTAMENTIT NE ALTIMETRI - FASADA JUGORE



PAMJE 3 DIMENSIONALE E APARTAMENTIT

NR.1



PAMJE 3 DIMENSIONALE E APARTAMENTIT

NR.2

“4 GODINA BANIMI DHE SHËRBIMI 5 KATE DHE 1 KAT PARKIM NËNTOKË”
Adresa: Pavarsia e Kosovës, Golem - Bashkia Kavajë

INVESTITOR DHE SUBJEKT NDERTUES:

"LOREDIS" Sh.p.k
NIPT: M32202503U
Kavajë / Albania
Tel: +355694080880

PROJEKTUES:

VAEKU STUDIO
NIPT: M11319016N
Adresa: "Kompleksi Magnet",
Njësia Lyra 2018_1
Njësia Administrative Nr.7
Tiranë/Albania
E-mail: u.hoxha@vaeku.studio
Tel: +355674088492



P.T

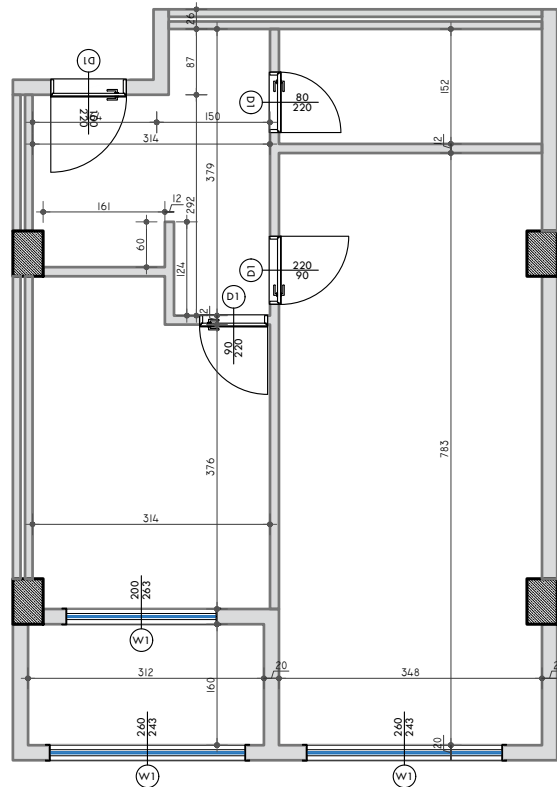

PLANIMETRIA E APARTAMENTIT - PERMASIM

SHKALLA 1:100

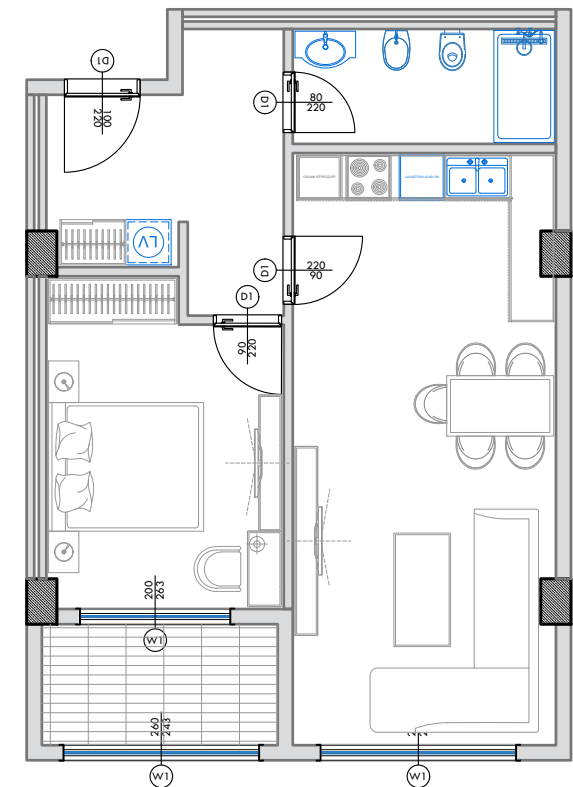

PLANIMETRIA E APARTAMENTIT - MOBILIM

SHKALLA 1:100

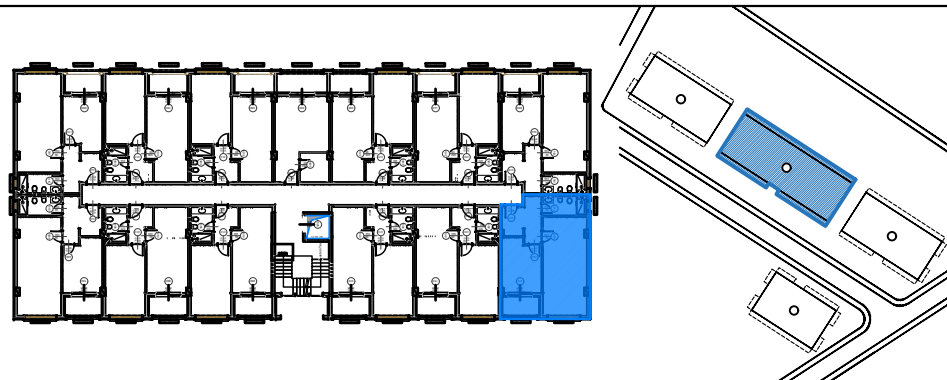

POZICIONI I APARTAMENTIT NE PLANIMETRINE E KATIT



POZICIONI I APARTAMENTIT NE ALTIMETRI - FASADA JUGORE



PAMJE 3 DIMENSIONALE E APARTAMENTIT

NR.1



PAMJE 3 DIMENSIONALE E APARTAMENTIT

NR.2

“4 GODINA BANIMI DHE SHËRBIMI 5 KATE DHE 1 KAT PARKIM NËNTOKË”
Adresa: Pavarsia e Kosovës, Golem - Bashkia Kavajë

INVESTITOR DHE SUBJEKT NDERTUES:

"LOREDIS" Sh.p.k
NIPT: M32202503U
Kavajë / Albania
Tel: +355694080880

PROJEKTUES:

VAEKU STUDIO
NIPT: M11319016N
Adresa: "Kompleksi Magnet",
Njësia Lyra 2018_1
Njësia Administrative Nr.7
Tiranë/Albania
E-mail: u.hoxha@vaeku.studio
Tel: +355674088492



APARTAMENTI NR:

17

Objekti Nr :

2

Kati :

2

Orientimi :

VERI

Siperfaqe Apartamenti :

67.4 m²

Ambjente te perbashketa:

7.2 m²

Siperfaqe totale:

74.6 m²



P.T

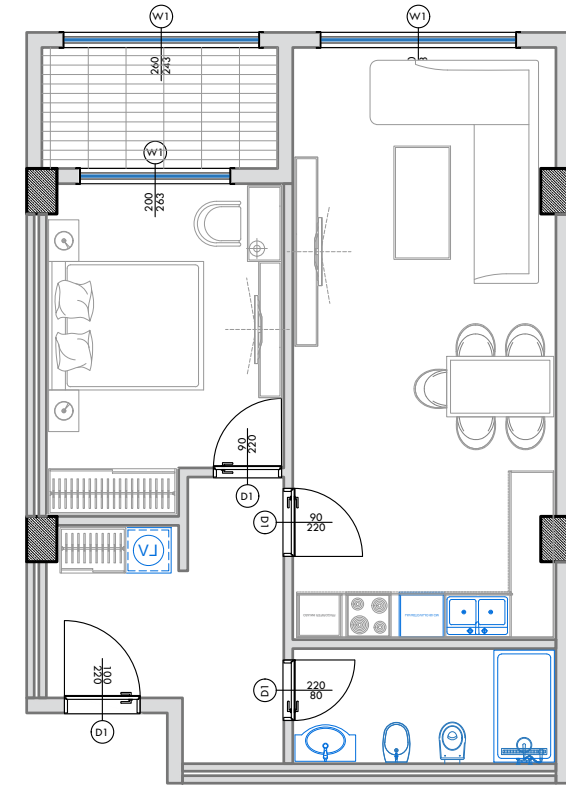
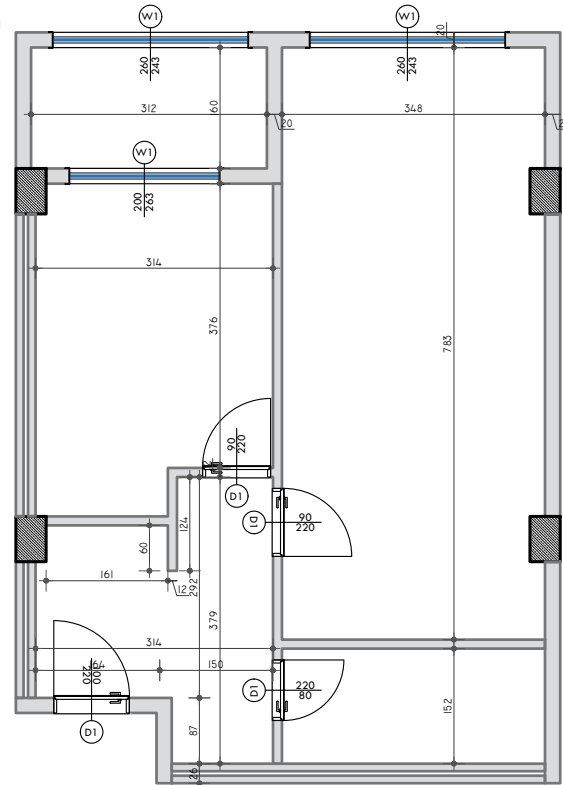

PLANIMETRIA E APARTAMENTIT - PERMASIM

SHKALLA 1:100

PLANIMETRIA E APARTAMENTIT - MOBILIM

SHKALLA 1:100

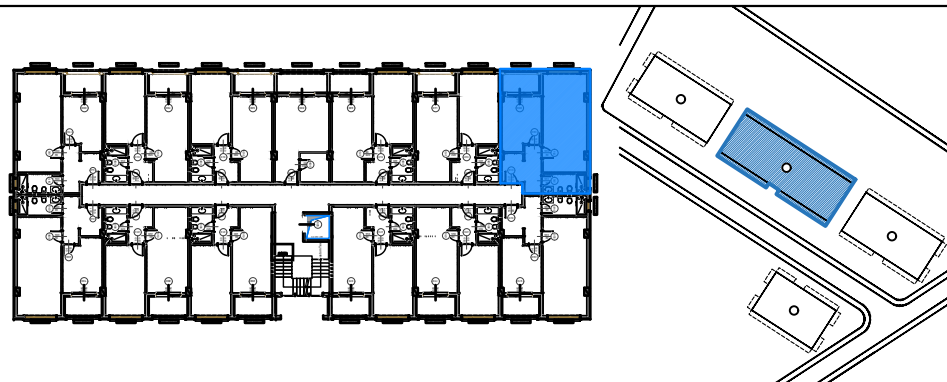

POZICIONI I APARTAMENTIT NE PLANIMETRINE E KATIT



POZICIONI I APARTAMENTIT NE ALTIMETRI - FASADA VERIORE



PAMJE 3 DIMENSIONALE E APARTAMENTIT

NR.1



PAMJE 3 DIMENSIONALE E APARTAMENTIT

NR.2

“4 GODINA BANIMI DHE SHËRBIMI 5 KATE DHE 1 KAT PARKIM NËNTOKË”
Adresa: Pavarsia e Kosovës, Golem - Bashkia Kavajë

INVESTITOR DHE SUBJEKT NDERTUES:

"LOREDIS" Sh.p.k
NIPT: M32202503U
Kavajë / Albania
Tel: +355694080880

PROJEKTUES:

VAEKU STUDIO
NIPT: M11319016N
Adresa: "Kompleksi Magnet",
Njësia Lyra 2018_1
Njësia Administrative Nr.7
Tiranë/Albania
E-mail: u.hoxha@vaeku.studio
Tel: +355674088492



P.T

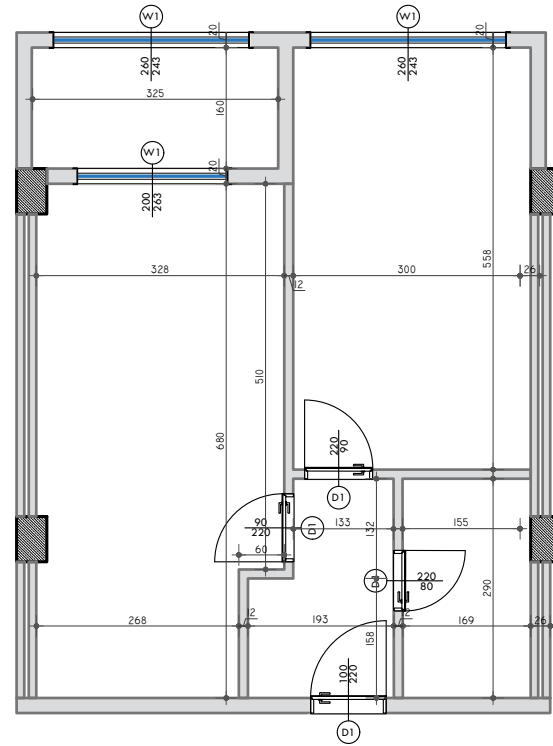

PLANIMETRIA E APARTAMENTIT - PERMASIM

SHKALLA 1:100

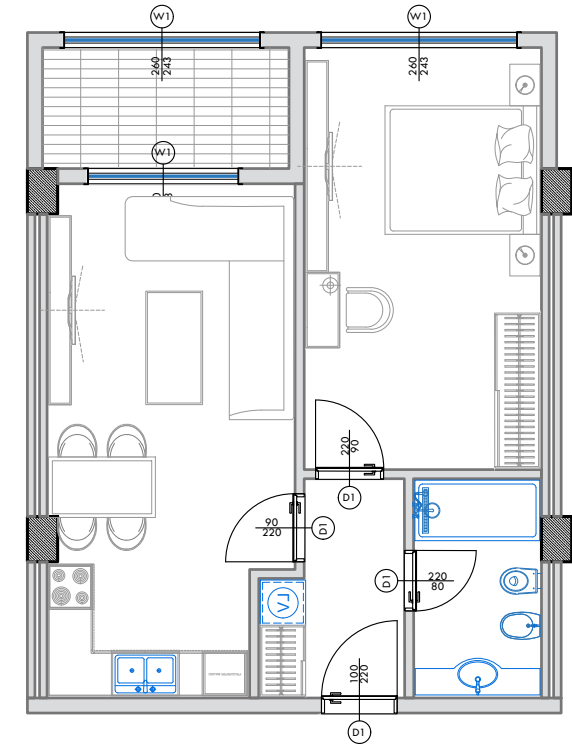

PLANIMETRIA E APARTAMENTIT - MOBILIM

SHKALLA 1:100

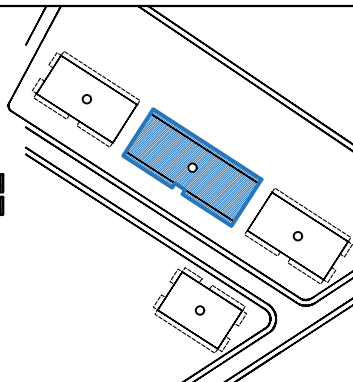

POZICIONI I APARTAMENTIT NE PLANIMETRINE E KATIT



POZICIONI I APARTAMENTIT NE ALTIMETRI - FASADA VERIORE



PAMJE 3 DIMENSIONALE E APARTAMENTIT

NR.1



PAMJE 3 DIMENSIONALE E APARTAMENTIT

NR.2

“4 GODINA BANIMI DHE SHËRBIMI 5 KATE DHE 1 KAT PARKIM NËNTOKË”
Adresa: Pavarsia e Kosovës, Golem - Bashkia Kavajë

INVESTITOR DHE SUBJEKT NDERTUES:

"LOREDIS" Sh.p.k
NIPT: M32202503U
Kavajë / Albania
Tel: +355694080880

PROJEKTUES:

VAEKU STUDIO
NIPT: M11319016N
Adresa: "Kompleksi Magnet",
Njësia Lyra 2018_1
Njësia Administrative Nr.7
Tiranë/Albania
E-mail: u.hoxha@vaeku.studio
Tel: +355674088492



APARTAMENTI NR:

19

Objekti Nr :

2

Kati :

2

Orientimi :

VERI

Siperfaqe Apartamenti :

61.0 m²

Ambjente te perbashketa:

6.5 m²

Siperfaqe totale:

67.5 m²



P.T

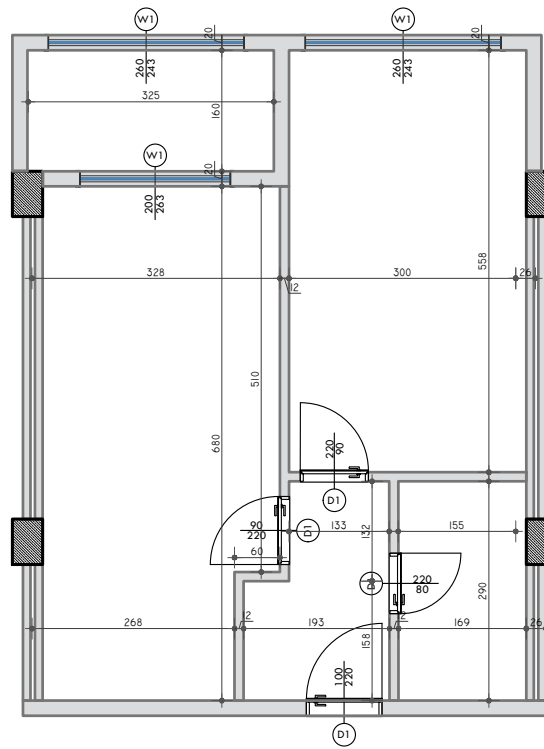

PLANIMETRIA E APARTAMENTIT - PERMASIM

SHKALLA 1:100

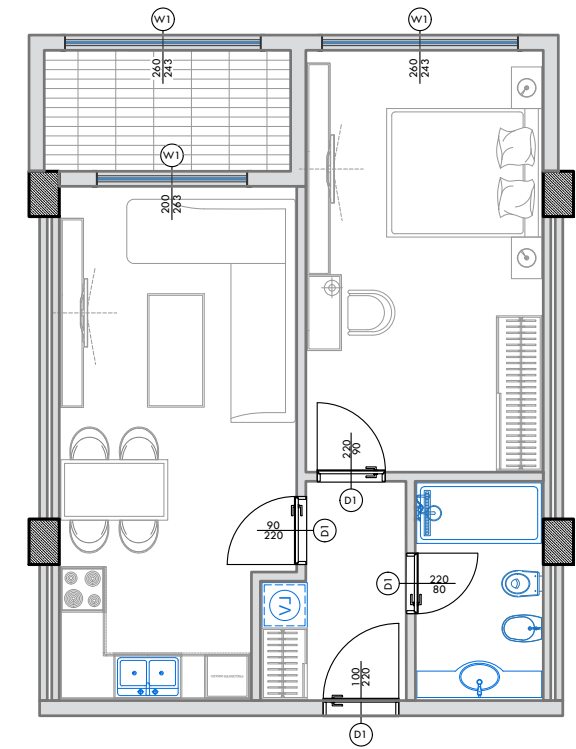

PLANIMETRIA E APARTAMENTIT - MOBILIM

SHKALLA 1:100

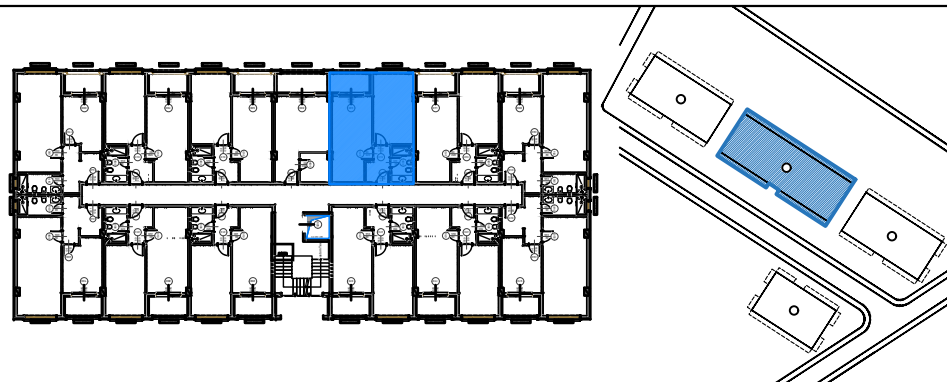

POZICIONI I APARTAMENTIT NE PLANIMETRINE E KATIT



POZICIONI I APARTAMENTIT NE ALTIMETRI - FASADA VERIORE



PAMJE 3 DIMENSIONALE E APARTAMENTIT

NR.1



PAMJE 3 DIMENSIONALE E APARTAMENTIT

NR.2

“4 GODINA BANIMI DHE SHËRBIMI 5 KATE DHE 1 KAT PARKIM NËNTOKË”
Adresa: Pavarsia e Kosovës, Golem - Bashkia Kavajë

INVESTITOR DHE SUBJEKT NDERTUES:

"LOREDIS" Sh.p.k
NIPT: M32202503U
Kavajë / Albania
Tel: +355694080880

PROJEKTUES:

VAEKU STUDIO
NIPT: M11319016N
Adresa: "Kompleksi Magnet",
Njësia Lyra 2018_1
Njësia Administrative Nr.7
Tiranë/Albania
E-mail: u.hoxha@vaeku.studio
Tel: +355674088492



APARTAMENTI NR:

21

Objekti Nr :

2

Kati :

2

Orientimi :

VERI

Siperfaqe Apartamenti :

61.0 m²

Ambjente te perbashketa:

6.5 m²

Siperfaqe totale:

67.5 m²



P.T

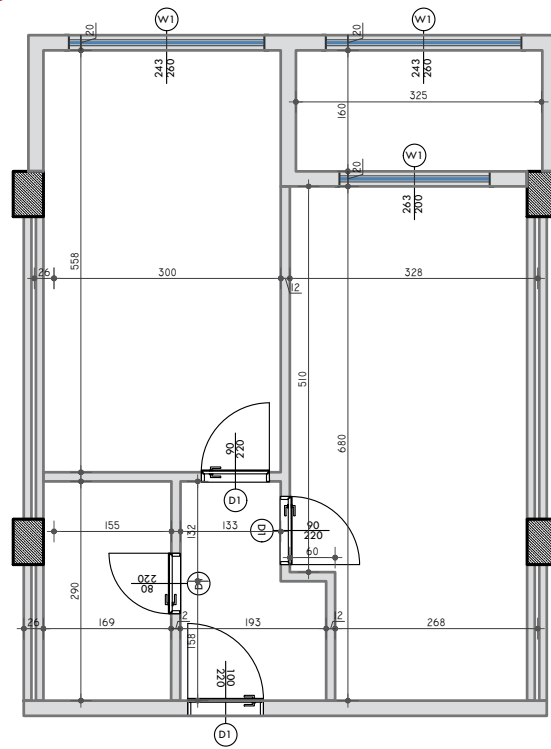

PLANIMETRIA E APARTAMENTIT - PERMASIM

SHKALLA 1:100

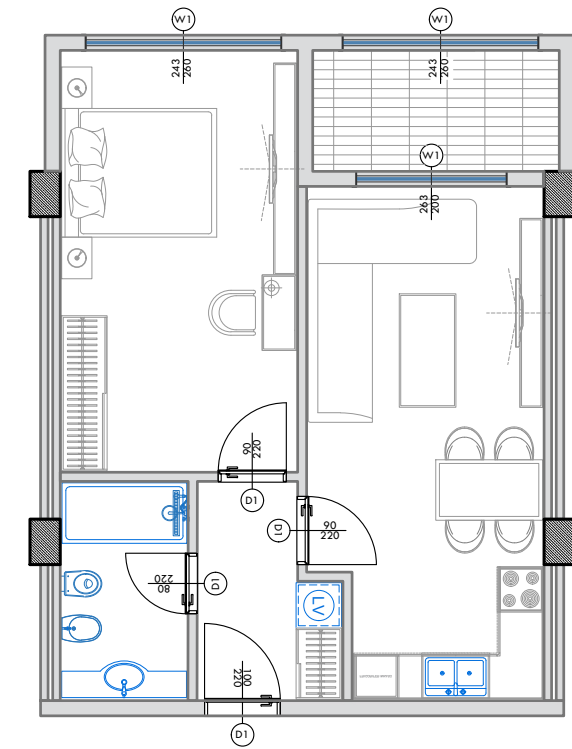

PLANIMETRIA E APARTAMENTIT - MOBILIM

SHKALLA 1:100

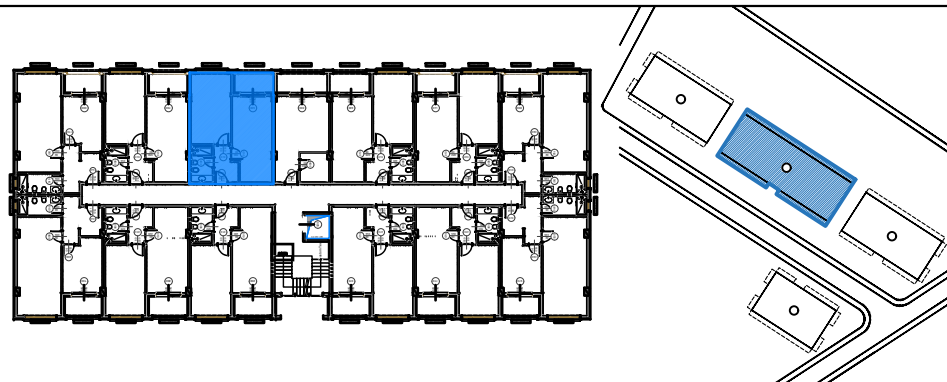

POZICIONI I APARTAMENTIT NE PLANIMETRINE E KATIT



POZICIONI I APARTAMENTIT NE ALTIMETRI - FASADA VERIORE



PAMJE 3 DIMENSIONALE E APARTAMENTIT

NR.1



PAMJE 3 DIMENSIONALE E APARTAMENTIT

NR.2

“4 GODINA BANIMI DHE SHËRBIMI 5 KATE DHE 1 KAT PARKIM NËNTOKË”
Adresa: Pavarsia e Kosovës, Golem - Bashkia Kavajë

INVESTITOR DHE SUBJEKT NDERTUES:

"LOREDIS" Sh.p.k
NIPT: M32202503U
Kavajë / Albania
Tel: +355694080880

PROJEKTUES:

VAEKU STUDIO
NIPT: M11319016N
Adresa: "Kompleksi Magnet",
Njësia Lyra 2018_1
Njësia Administrative Nr.7
Tiranë/Albania
E-mail: u.hoxha@vaeku.studio
Tel: +355674088492



APARTAMENTI NR:

22

Objekti Nr :

2

Kati :

2

Orientimi :

VERI

Siperfaqe Apartamenti :

61.0 m²

Ambjente te perbashketa:

6.5 m²

Siperfaqe totale:

67.5 m²



P.T

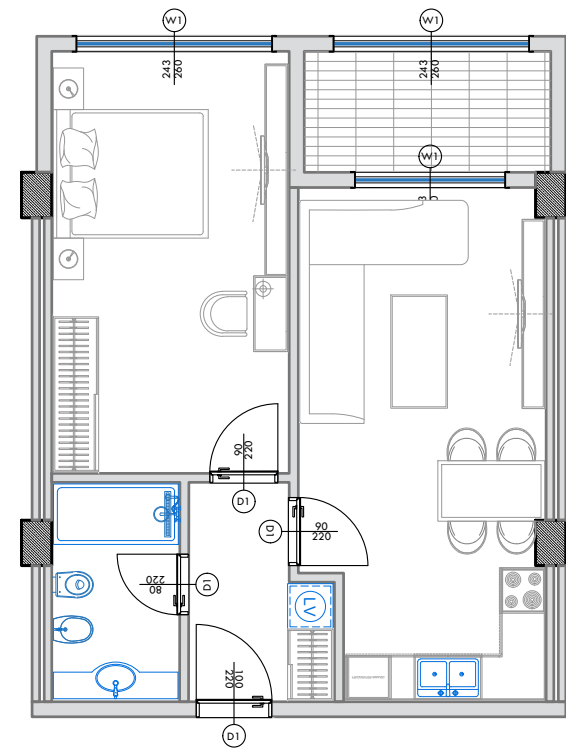
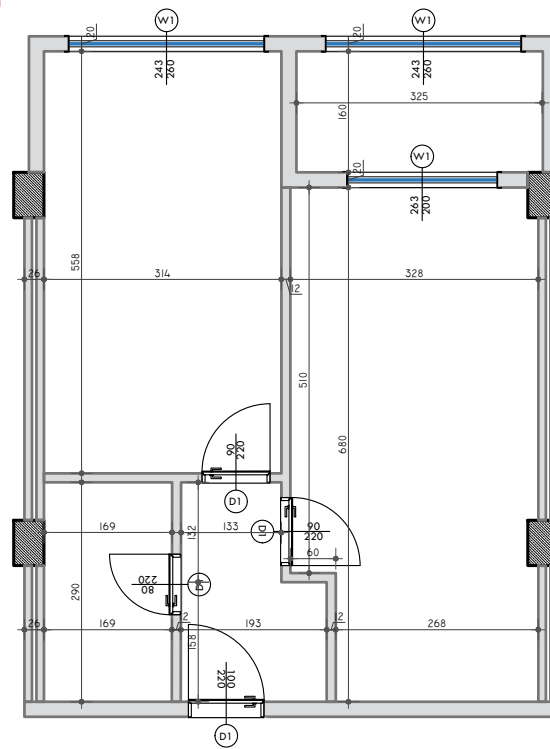

PLANIMETRIA E APARTAMENTIT - PERMASIM

SHKALLA 1:100

PLANIMETRIA E APARTAMENTIT - MOBILIM

SHKALLA 1:100

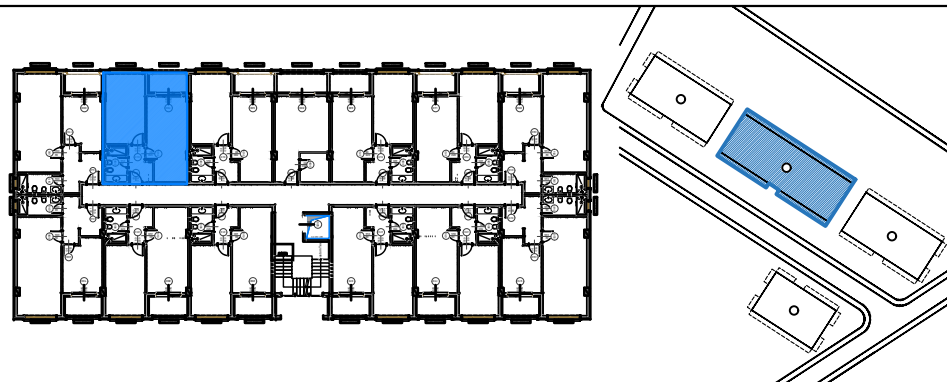

POZICIONI I APARTAMENTIT NE PLANIMETRINE E KATIT



POZICIONI I APARTAMENTIT NE ALTIMETRI - FASADA VERIORE



PAMJE 3 DIMENSIONALE E APARTAMENTIT

NR.1



PAMJE 3 DIMENSIONALE E APARTAMENTIT

NR.2

“4 GODINA BANIMI DHE SHËRBIMI 5 KATE DHE 1 KAT PARKIM NËNTOKË”
Adresa: Pavarsia e Kosovës, Golem - Bashkia Kavajë

INVESTITOR DHE SUBJEKT NDERTUES:

"LOREDIS" Sh.p.k
NIPT: M32202503U
Kavajë / Albania
Tel: +355694080880

PROJEKTUES:

VAEKU STUDIO
NIPT: M11319016N
Adresa: "Kompleksi Magnet",
Njësia Lyra 2018_1
Njësia Administrative Nr.7
Tiranë/Albania
E-mail: u.hoxha@vaeku.studio
Tel: +355674088492



APARTAMENTI NR:

24

Objekti Nr :

2

Kati :

2

Orientimi :

JUG

Siperfaqe Apartamenti :

67.4 m²

Ambjente te perbashketa:

7.2 m²

Siperfaqe totale:

74.6 m²



P.T

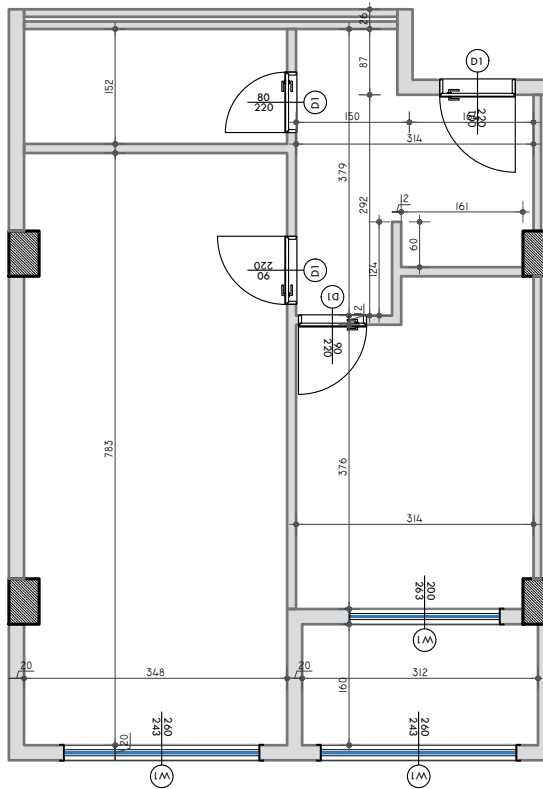

PLANIMETRIA E APARTAMENTIT - PERMASIM

SHKALLA 1:100

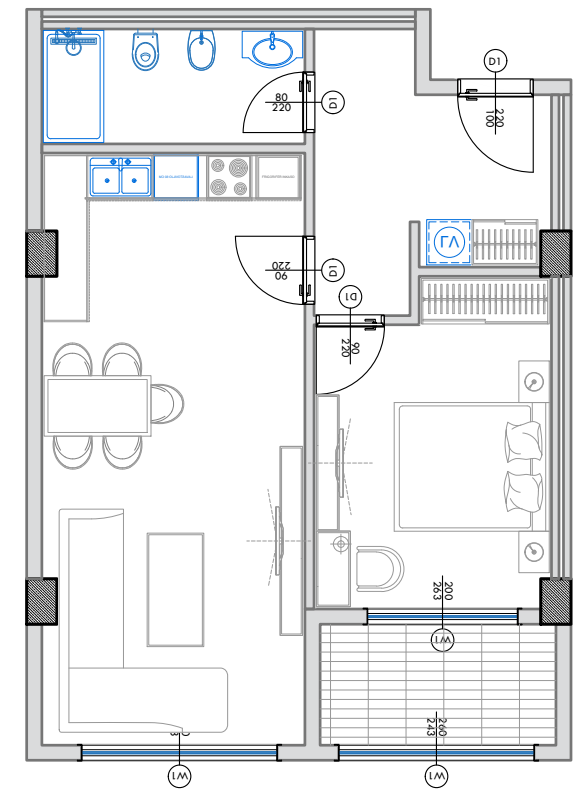

PLANIMETRIA E APARTAMENTIT - MOBILIM

SHKALLA 1:100

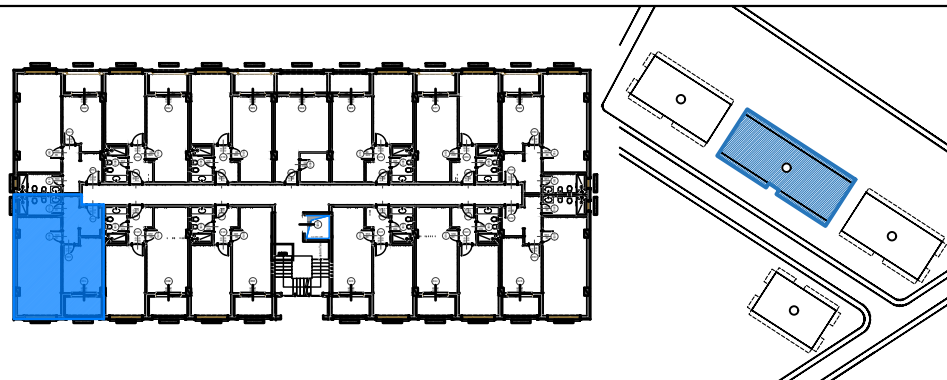

POZICIONI I APARTAMENTIT NE PLANIMETRINE E KATIT



POZICIONI I APARTAMENTIT NE ALTIMETRI - FASADA JUGORE



PAMJE 3 DIMENSIONALE E APARTAMENTIT

NR.1



PAMJE 3 DIMENSIONALE E APARTAMENTIT

NR.2

“4 GODINA BANIMI DHE SHËRBIMI 5 KATE DHE 1 KAT PARKIM NËNTOKË”
Adresa: Pavarsia e Kosovës, Golem - Bashkia Kavajë

INVESTITOR DHE SUBJEKT NDERTUES:

"LOREDIS" Sh.p.k
NIPT: M32202503U
Kavajë / Albania
Tel: +355694080880

PROJEKTUES:

VAEKU STUDIO
NIPT: M11319016N
Adresa: "Kompleksi Magnet",
Njësia Lyra 2018_1
Njësia Administrative Nr.7
Tiranë/Albania
E-mail: u.hoxha@vaeku.studio
Tel: +355674088492



P.T

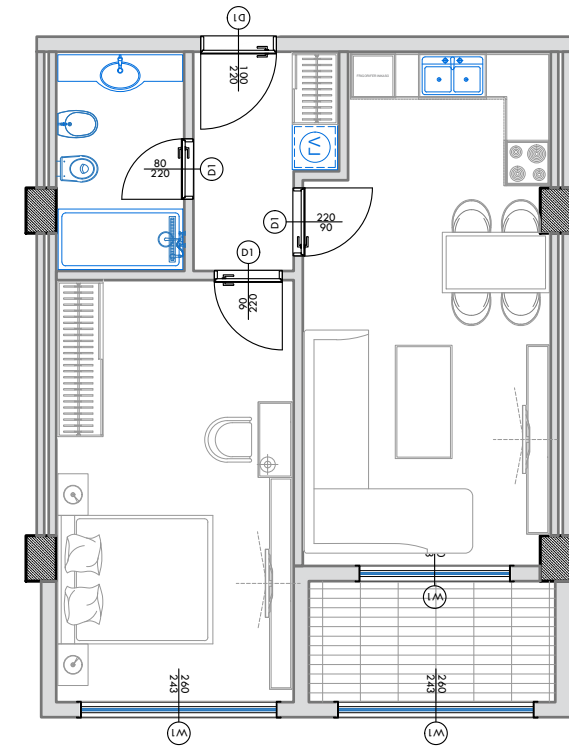
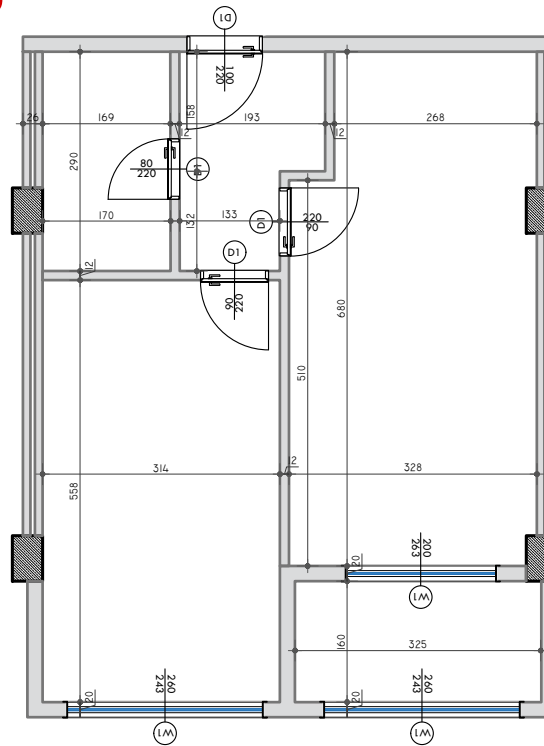

APARTAMENTI NR:	25
Objekti Nr :	2
Kati :	2
Orientimi :	JUG
Siperfaqe Apartamenti :	61.0 m ²
Ambjente te perbashketa:	6.5 m ²
Siperfaqe totale:	67.5 m ²



PLANIMETRIA E APARTAMENTIT - PERMASIM

SHKALLA 1:100

PLANIMETRIA E APARTAMENTIT - MOBILIM

SHKALLA 1:100

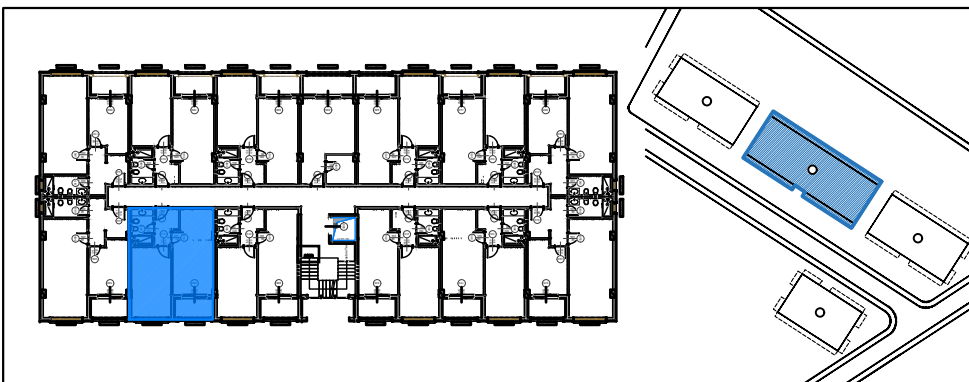

POZICIONI I APARTAMENTIT NE PLANIMETRINE E KATIT



POZICIONI I APARTAMENTIT NE ALTIMETRI - FASADA JUGORE



PAMJE 3 DIMENSIONALE E APARTAMENTIT

NR.1



PAMJE 3 DIMENSIONALE E APARTAMENTIT

NR.2

“4 GODINA BANIMI DHE SHËRBIMI 5 KATE DHE 1 KAT PARKIM NËNTOKË”
Adresa: Pavarsia e Kosovës, Golem - Bashkia Kavajë

INVESTITOR DHE SUBJEKT NDERTUES:

"LOREDIS" Sh.p.k
NIPT: M32202503U
Kavajë / Albania
Tel: +355694080880

PROJEKTUES:

VAEKU STUDIO
NIPT: M11319016N
Adresa: "Kompleksi Magnet",
Njësia Lyra 2018_1
Njësia Administrative Nr.7
Tiranë/Albania
E-mail: u.hoxha@vaeku.studio
Tel: +355674088492



P.T

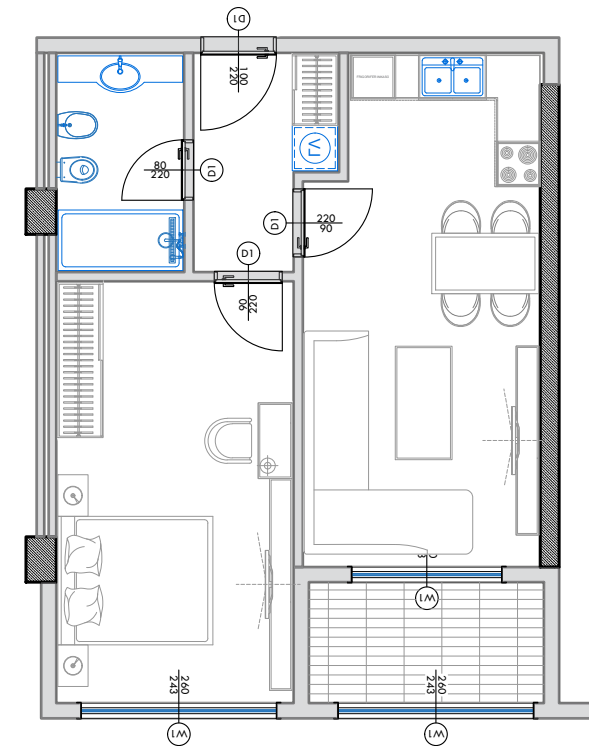
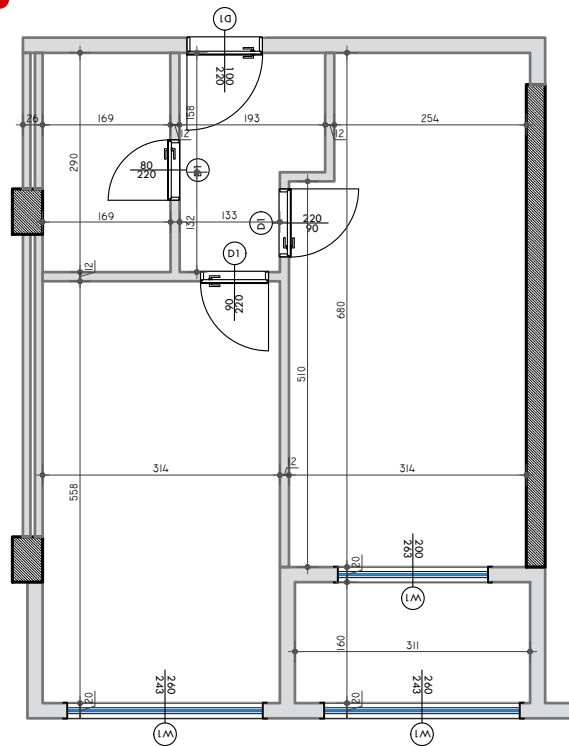

PLANIMETRIA E APARTAMENTIT - PERMASIM

SHKALLA 1:100

PLANIMETRIA E APARTAMENTIT - MOBILIM

SHKALLA 1:100

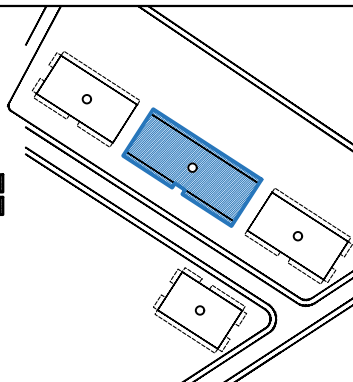

POZICIONI I APARTAMENTIT NE PLANIMETRINE E KATIT



POZICIONI I APARTAMENTIT NE ALTIMETRI - FASADA JUGORE



PAMJE 3 DIMENSIONALE E APARTAMENTIT

NR.1



PAMJE 3 DIMENSIONALE E APARTAMENTIT

NR.2

“4 GODINA BANIMI DHE SHËRBIMI 5 KATE DHE 1 KAT PARKIM NËNTOKË”
Adresa: Pavarsia e Kosovës, Golem - Bashkia Kavajë

INVESTITOR DHE SUBJEKT NDERTUES:

"LOREDIS" Sh.p.k
NIPT: M32202503U
Kavajë / Albania
Tel: +355694080880

PROJEKTUES:

VAEKU STUDIO
NIPT: M11319016N
Adresa: "Kompleksi Magnet",
Njësia Lyra 2018_1
Njësia Administrative Nr.7
Tiranë/Albania
E-mail: u.hoxha@vaeku.studio
Tel: +355674088492



APARTAMENTI NR:

27

Objekti Nr :

2

Kati :

3

Orientimi :

JUG

Siperfaqe Apartamenti :

61.0 m²

Ambjente te perbashketa:

6.5 m²

Siperfaqe totale:

67.5 m²



P.T

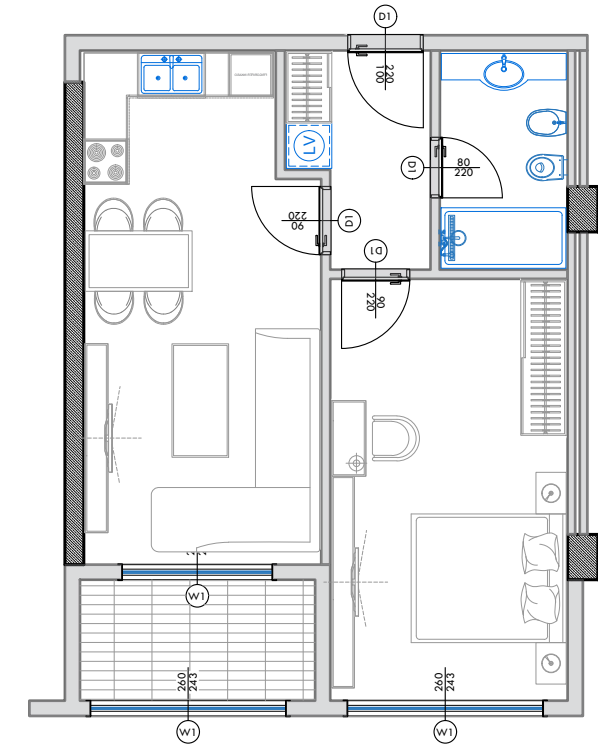
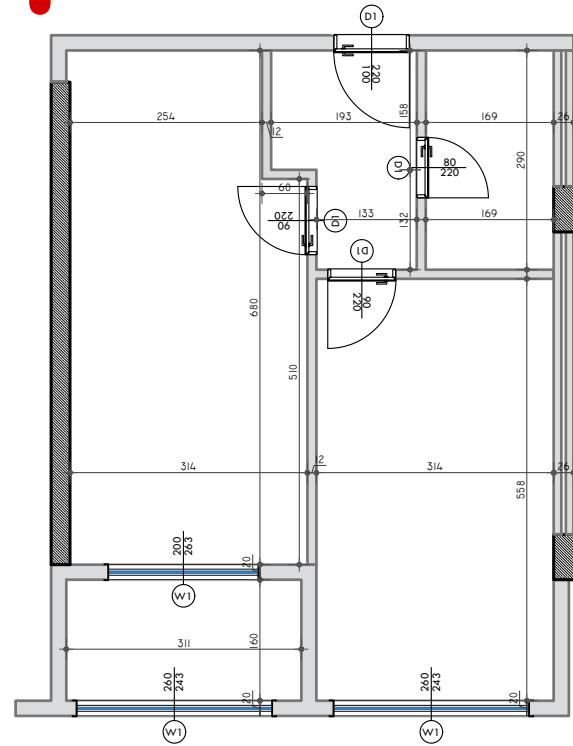

PLANIMETRIA E APARTAMENTIT - PERMASIM

SHKALLA 1:100

PLANIMETRIA E APARTAMENTIT - MOBILIM

SHKALLA 1:100

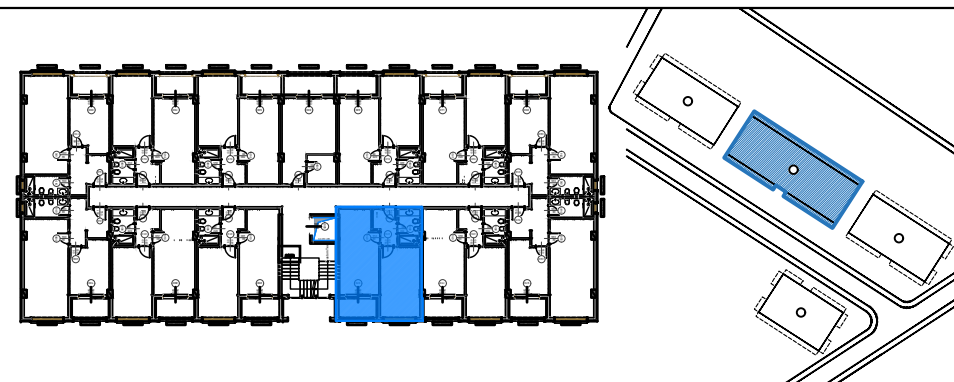

POZICIONI I APARTAMENTIT NE PLANIMETRINE E KATIT



PAMJE 3 DIMENSIONALE E APARTAMENTIT

NR.1



PAMJE 3 DIMENSIONALE E APARTAMENTIT

NR.2



POZICIONI I APARTAMENTIT NE ALTIMETRI - FASADA JUGORE

“4 GODINA BANIMI DHE SHËRBIMI 5 KATE DHE 1 KAT PARKIM NËNTOKË”
Adresa: Pavarsia e Kosovës, Golem - Bashkia Kavajë

INVESTITOR DHE SUBJEKT NDERTUES:

"LOREDIS" Sh.p.k
NIPT: M32202503U
Kavajë / Albania
Tel: +355694080880

PROJEKTUES:

VAEKU STUDIO
NIPT: M11319016N
Adresa: "Kompleksi Magnet",
Njësia Lyra 2018_1
Njësia Administrative Nr.7
Tiranë/Albania
E-mail: u.hoxha@vaeku.studio
Tel: +355674088492



P.T

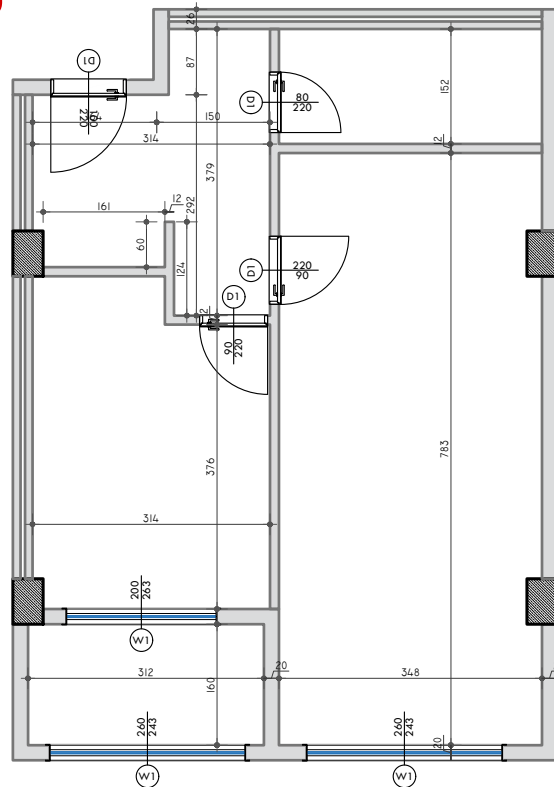

PLANIMETRIA E APARTAMENTIT - PERMASIM

SHKALLA 1:100

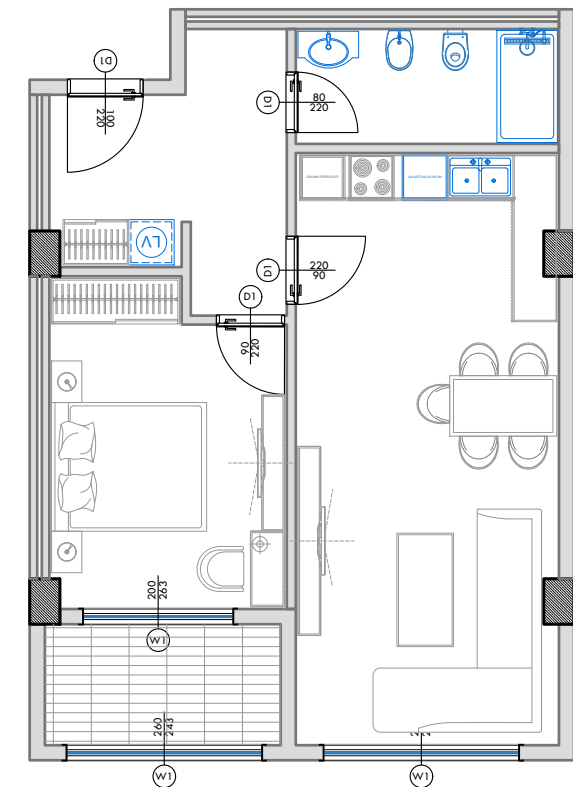

PLANIMETRIA E APARTAMENTIT - MOBILIM

SHKALLA 1:100

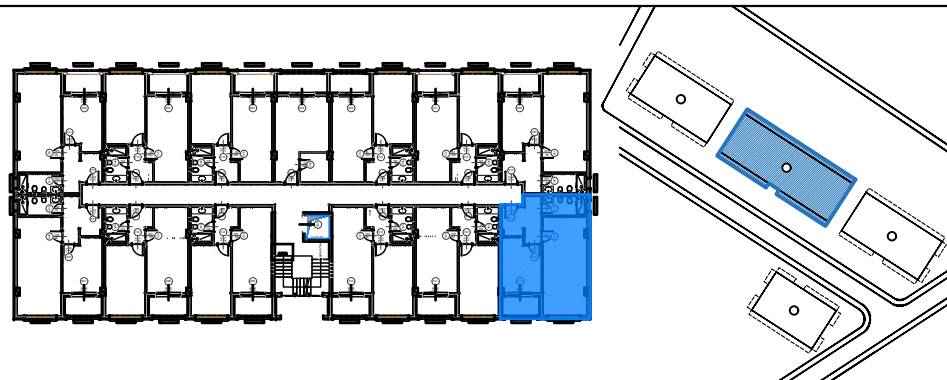

POZICIONI I APARTAMENTIT NE PLANIMETRINE E KATIT



POZICIONI I APARTAMENTIT NE ALTIMETRI - FASADA JUGORE



PAMJE 3 DIMENSIONALE E APARTAMENTIT

NR.1



PAMJE 3 DIMENSIONALE E APARTAMENTIT

NR.2

“4 GODINA BANIMI DHE SHËRBIMI 5 KATE DHE 1 KAT PARKIM NËNTOKË”
Adresa: Pavarsia e Kosovës, Golem - Bashkia Kavajë

INVESTITOR DHE SUBJEKT NDERTUES:

"LOREDIS" Sh.p.k
NIPT: M32202503U
Kavajë / Albania
Tel: +355694080880

PROJEKTUES:

VAEKU STUDIO
NIPT: M11319016N
Adresa: "Kompleksi Magnet",
Njësia Lyra 2018_1
Njësia Administrative Nr.7
Tiranë/Albania
E-mail: u.hoxha@vaeku.studio
Tel: +355674088492



APARTAMENTI NR:

30

Objekti Nr :

2

Kati :

3

Orientimi :

VERI

Siperfaqe Apartamenti :

67.4 m²

Ambjente te perbashketa:

7.2 m²

Siperfaqe totale:

74.6 m²



P.T

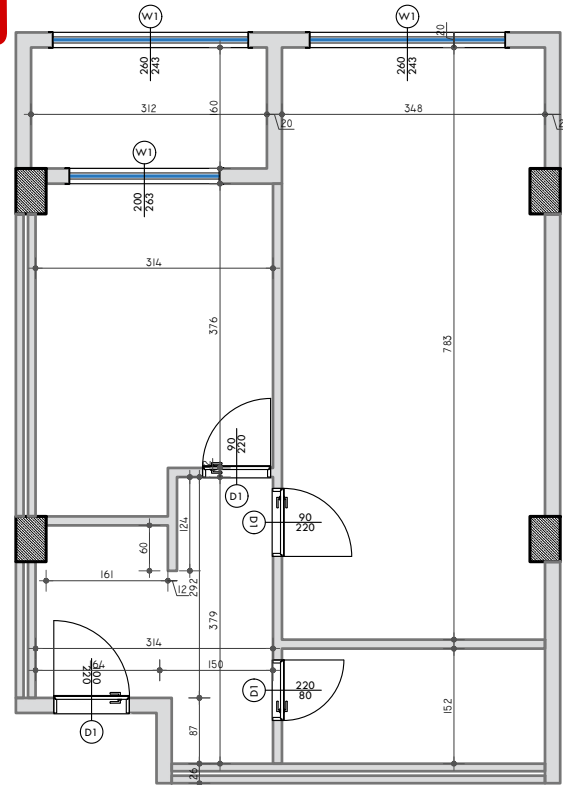

PLANIMETRIA E APARTAMENTIT - PERMASIM

SHKALLA 1:100

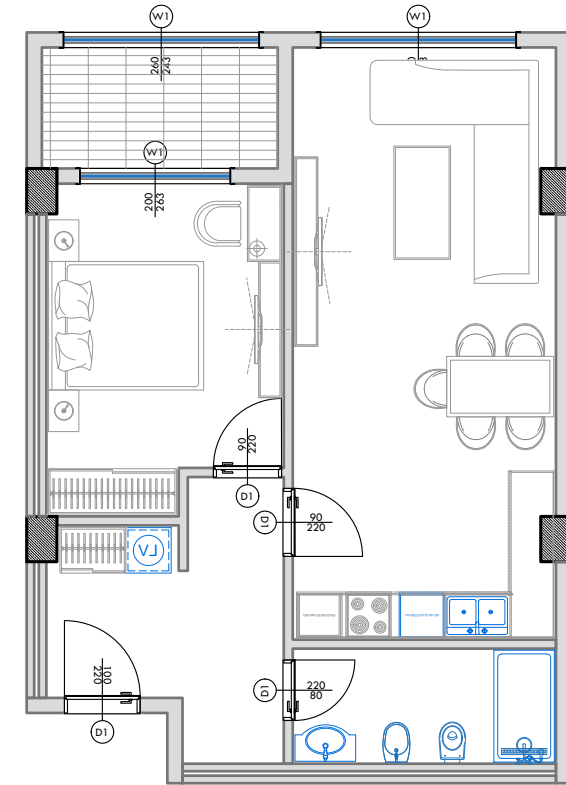

PLANIMETRIA E APARTAMENTIT - MOBILIM

SHKALLA 1:100

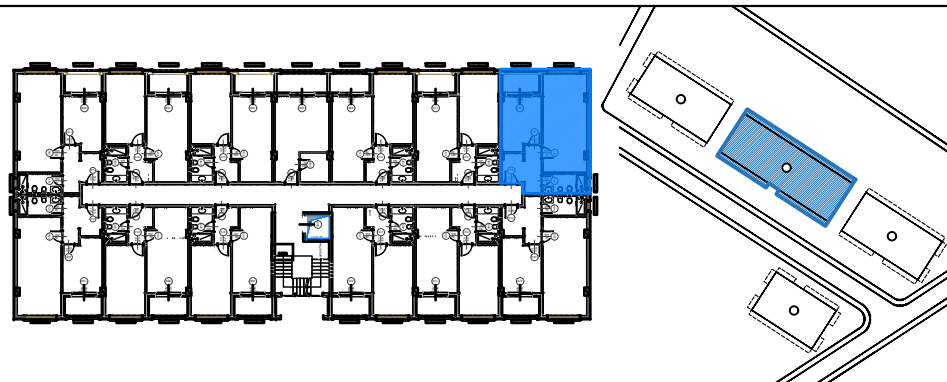

POZICIONI I APARTAMENTIT NE PLANIMETRINE E KATIT



POZICIONI I APARTAMENTIT NE ALTIMETRI - FASADA VERIORE



PAMJE 3 DIMENSIONALE E APARTAMENTIT

NR.1



PAMJE 3 DIMENSIONALE E APARTAMENTIT

NR.2

“4 GODINA BANIMI DHE SHËRBIMI 5 KATE DHE 1 KAT PARKIM NËNTOKË”
Adresa: Pavarsia e Kosovës, Golem - Bashkia Kavajë

INVESTITOR DHE SUBJEKT NDERTUES:

"LOREDIS" Sh.p.k
NIPT: M32202503U
Kavajë / Albania
Tel: +355694080880

PROJEKTUES:

VAEKU STUDIO
NIPT: M11319016N
Adresa: "Kompleksi Magnet",
Njësia Lyra 2018_1
Njësia Administrative Nr.7
Tiranë/Albania
E-mail: u.hoxha@vaeku.studio
Tel: +355674088492



P.T

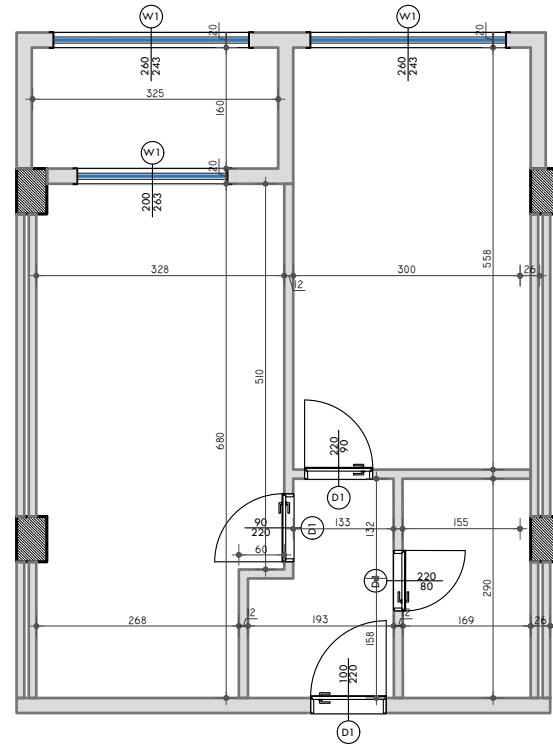

PLANIMETRIA E APARTAMENTIT - PERMASIM

SHKALLA 1:100

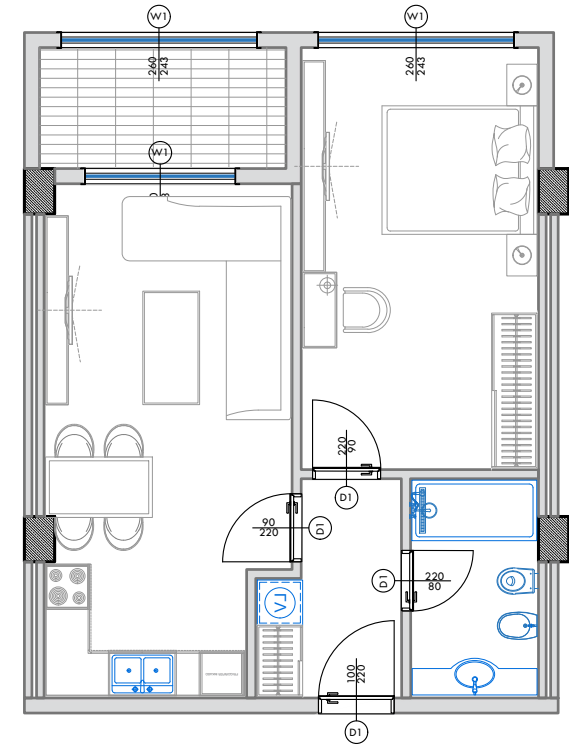

PLANIMETRIA E APARTAMENTIT - MOBILIM

SHKALLA 1:100

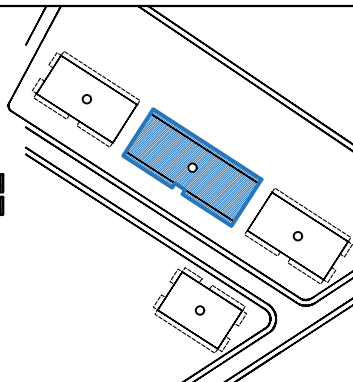

POZICIONI I APARTAMENTIT NE PLANIMETRINE E KATIT



POZICIONI I APARTAMENTIT NE ALTIMETRI - FASADA VERIORE



PAMJE 3 DIMENSIONALE E APARTAMENTIT

NR.1



PAMJE 3 DIMENSIONALE E APARTAMENTIT

NR.2

“4 GODINA BANIMI DHE SHËRBIMI 5 KATE DHE 1 KAT PARKIM NËNTOKË”
Adresa: Pavarsia e Kosovës, Golem - Bashkia Kavajë

INVESTITOR DHE SUBJEKT NDERTUES:

"LOREDIS" Sh.p.k
NIPT: M32202503U
Kavajë / Albania
Tel: +355694080880

PROJEKTUES:

VAEKU STUDIO
NIPT: M11319016N
Adresa: "Kompleksi Magnet",
Njësia Lyra 2018_1
Njësia Administrative Nr.7
Tiranë/Albania
E-mail: u.hoxha@vaeku.studio
Tel: +355674088492



P.T

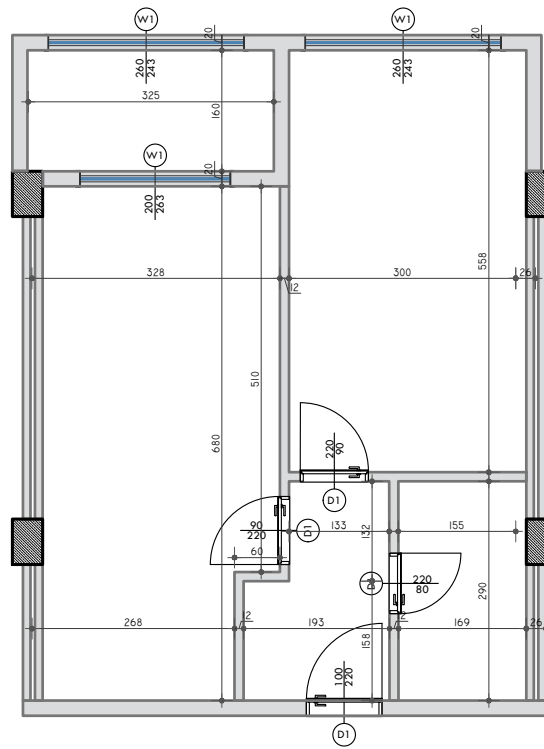

PLANIMETRIA E APARTAMENTIT - PERMASIM

SHKALLA 1:100

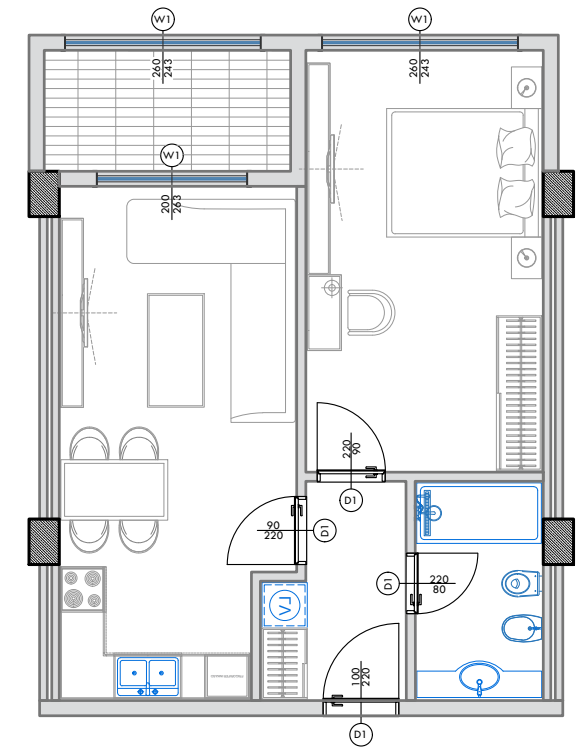

PLANIMETRIA E APARTAMENTIT - MOBILIM

SHKALLA 1:100

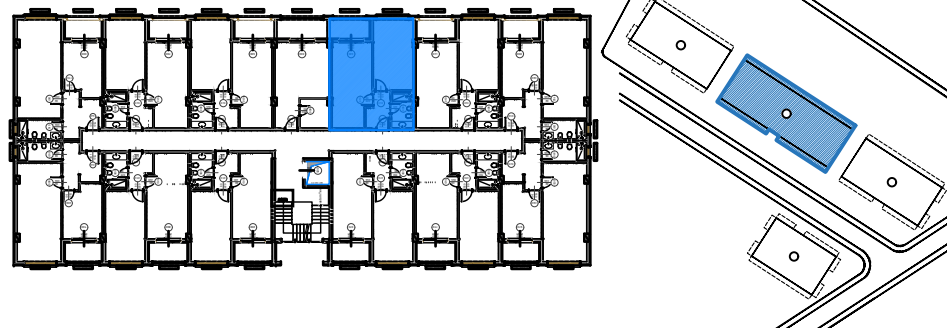

POZICIONI I APARTAMENTIT NE PLANIMETRINE E KATIT



POZICIONI I APARTAMENTIT NE ALTIMETRI - FASADA VERIORE



PAMJE 3 DIMENSIONALE E APARTAMENTIT

NR.1



PAMJE 3 DIMENSIONALE E APARTAMENTIT

NR.2

“4 GODINA BANIMI DHE SHËRBIMI 5 KATE DHE 1 KAT PARKIM NËNTOKË”
Adresa: Pavarsia e Kosovës, Golem - Bashkia Kavajë

INVESTITOR DHE SUBJEKT NDERTUES:

"LOREDIS" Sh.p.k
NIPT: M32202503U
Kavajë / Albania
Tel: +355694080880

PROJEKTUES:

VAEKU STUDIO
NIPT: M11319016N
Adresa: "Kompleksi Magnet",
Njësia Lyra 2018_1
Njësia Administrative Nr.7
Tiranë/Albania
E-mail: u.hoxha@vaeku.studio
Tel: +355674088492



APARTAMENTI NR:	34
Objekti Nr :	2
Kati :	3
Orientimi :	VERI
Siperfaqe Apartamenti :	61.0 m ²
Ambjente te perbashketa:	6.5 m ²
Siperfaqe totale:	67.5 m ²



P.T

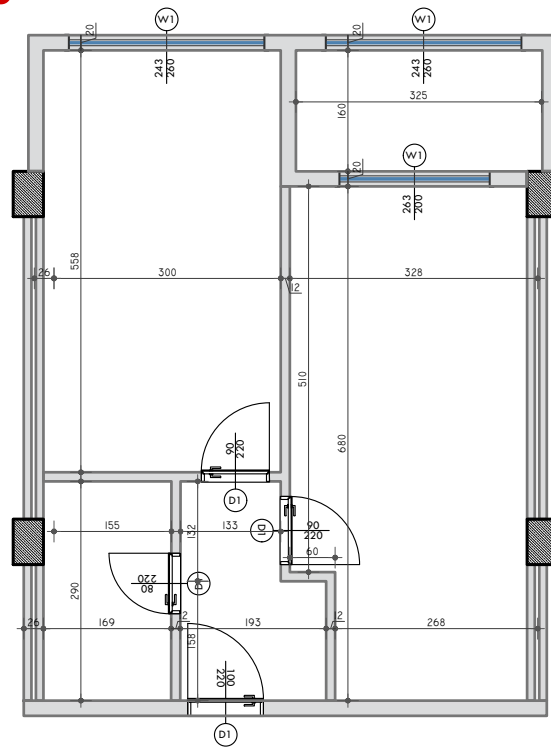

PLANIMETRIA E APARTAMENTIT - PERMASIM

SHKALLA 1:100

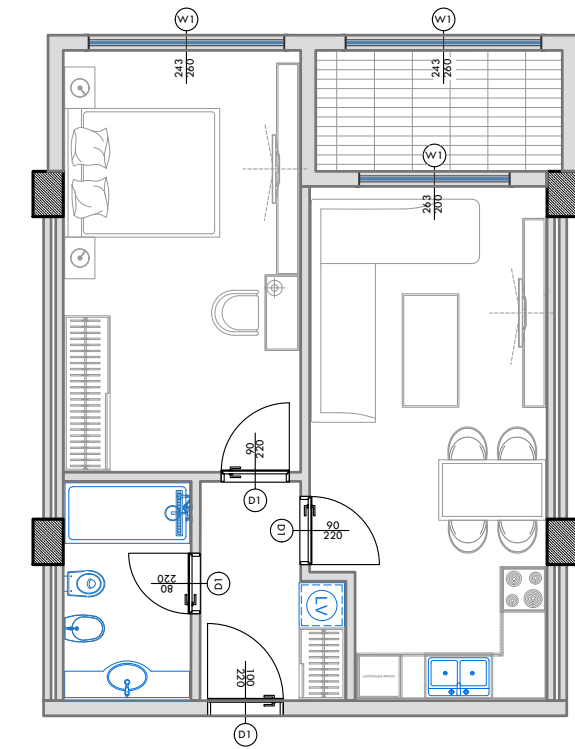

PLANIMETRIA E APARTAMENTIT - MOBILIM

SHKALLA 1:100

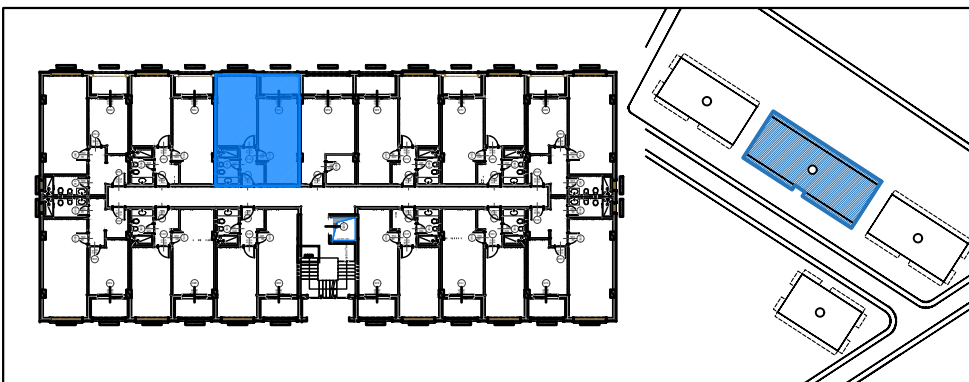

POZICIONI I APARTAMENTIT NE PLANIMETRINE E KATIT



POZICIONI I APARTAMENTIT NE ALTIMETRI - FASADA VERIORE



PAMJE 3 DIMENSIONALE E APARTAMENTIT

NR.1



PAMJE 3 DIMENSIONALE E APARTAMENTIT

NR.2

“4 GODINA BANIMI DHE SHËRBIMI 5 KATE DHE 1 KAT PARKIM NËNTOKË”
Adresa: Pavarsia e Kosovës, Golem - Bashkia Kavajë

INVESTITOR DHE SUBJEKT NDERTUES:

"LOREDIS" Sh.p.k
NIPT: M32202503U
Kavajë / Albania
Tel: +355694080880

PROJEKTUES:

VAEKU STUDIO
NIPT: M11319016N
Adresa: "Kompleksi Magnet",
Njësia Lyra 2018_1
Njësia Administrative Nr.7
Tiranë/Albania
E-mail: u.hoxha@vaeku.studio
Tel: +355674088492



P.T

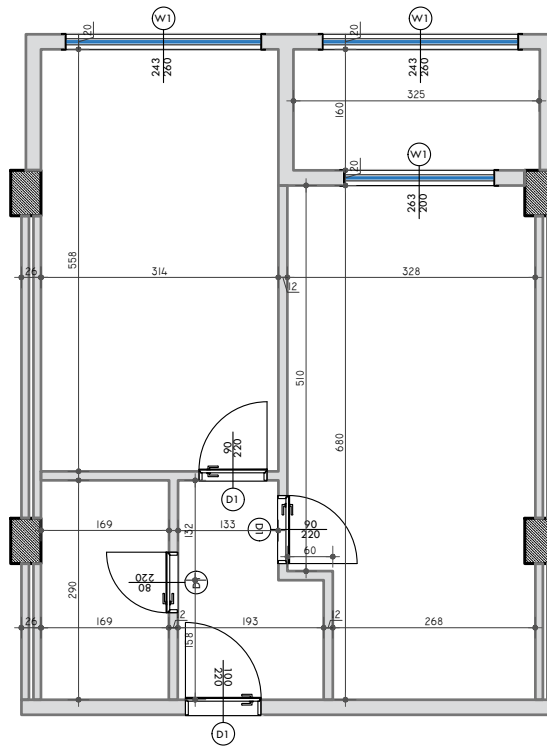

PLANIMETRIA E APARTAMENTIT - PERMASIM

SHKALLA 1:100

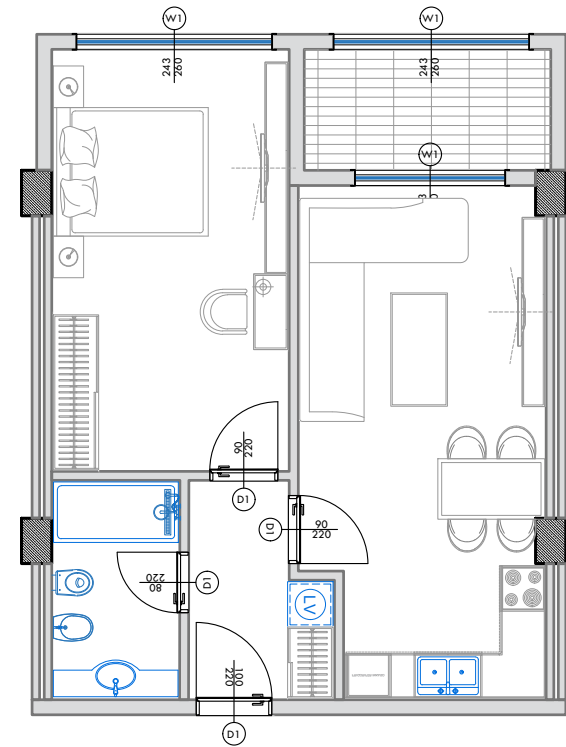

PLANIMETRIA E APARTAMENTIT - MOBILIM

SHKALLA 1:100

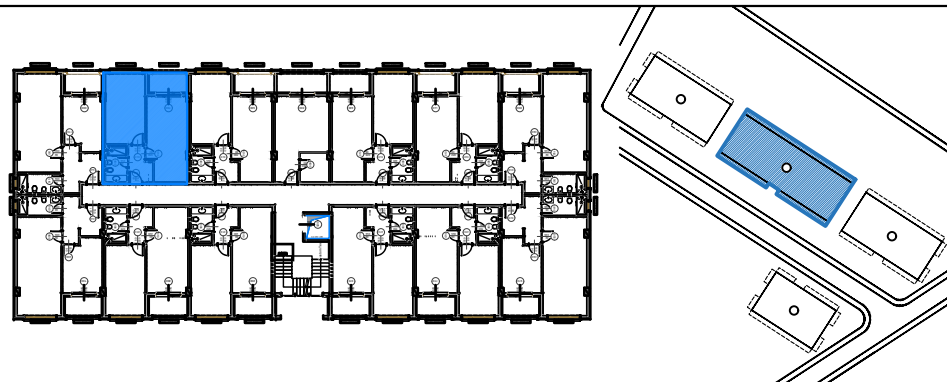

POZICIONI I APARTAMENTIT NE PLANIMETRINE E KATIT



POZICIONI I APARTAMENTIT NE ALTIMETRI - FASADA VERIORE



PAMJE 3 DIMENSIONALE E APARTAMENTIT

NR.1



PAMJE 3 DIMENSIONALE E APARTAMENTIT

NR.2

“4 GODINA BANIMI DHE SHËRBIMI 5 KATE DHE 1 KAT PARKIM NËNTOKË”
Adresa: Pavarsia e Kosovës, Golem - Bashkia Kavajë

INVESTITOR DHE SUBJEKT NDERTUES:

"LOREDIS" Sh.p.k
NIPT: M32202503U
Kavajë / Albania
Tel: +355694080880

PROJEKTUES:

VAEKU STUDIO
NIPT: M11319016N
Adresa: "Kompleksi Magnet",
Njësia Lyra 2018_1
Njësia Administrative Nr.7
Tiranë/Albania
E-mail: u.hoxha@vaeku.studio
Tel: +355674088492



APARTAMENTI NR:

37

Objekti Nr :

2

Kati :

3

Orientimi :

JUG

Siperfaqe Apartamenti :

67.4 m²

Ambjente te perbashketa:

7.2 m²

Siperfaqe totale:

74.6 m²



P.T

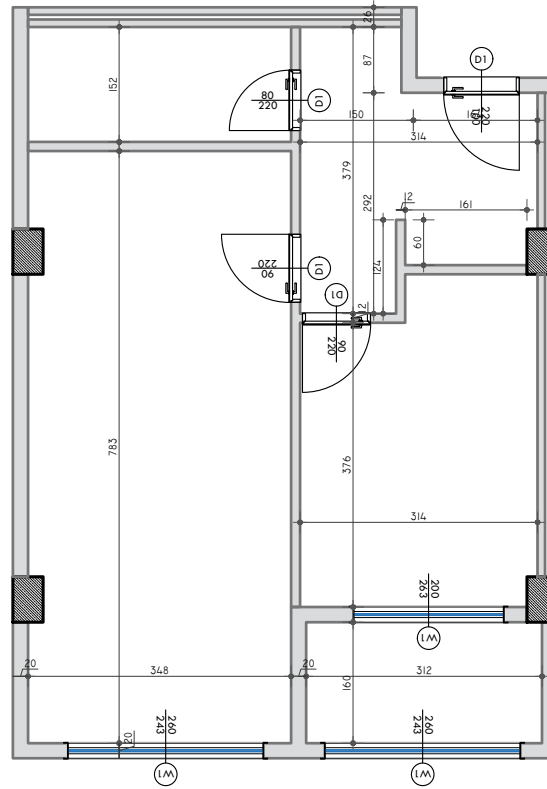

PLANIMETRIA E APARTAMENTIT - PERMASIM

SHKALLA 1:100

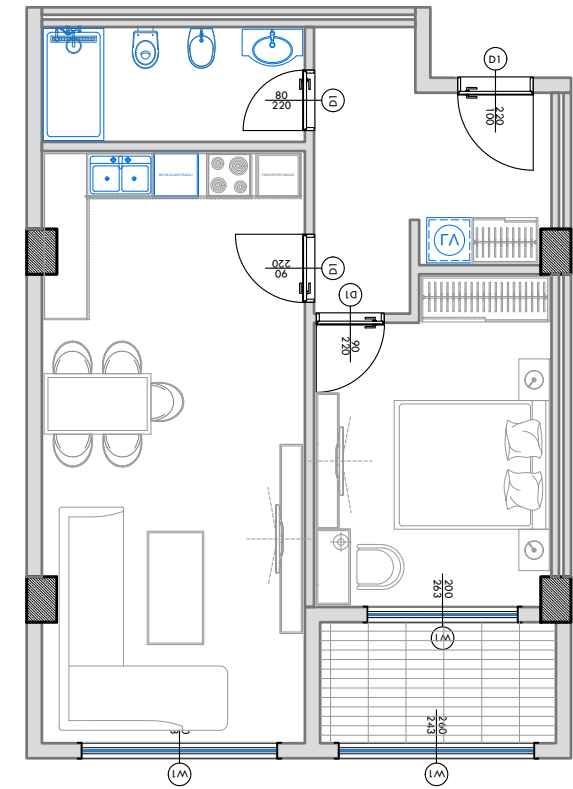

PLANIMETRIA E APARTAMENTIT - MOBILIM

SHKALLA 1:100

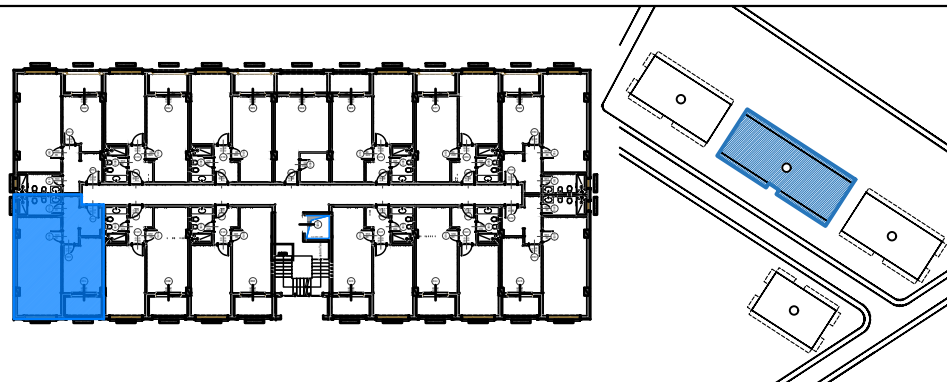

POZICIONI I APARTAMENTIT NE PLANIMETRINE E KATIT



POZICIONI I APARTAMENTIT NE ALTIMETRI - FASADA JUGORE



PAMJE 3 DIMENSIONALE E APARTAMENTIT

NR.1



PAMJE 3 DIMENSIONALE E APARTAMENTIT

NR.2

“4 GODINA BANIMI DHE SHËRBIMI 5 KATE DHE 1 KAT PARKIM NËNTOKË”
Adresa: Pavarsia e Kosovës, Golem - Bashkia Kavajë

INVESTITOR DHE SUBJEKT NDERTUES:

"LOREDIS" Sh.p.k
NIPT: M32202503U
Kavajë / Albania
Tel: +355694080880

PROJEKTUES:

VAEKU STUDIO
NIPT: M11319016N
Adresa: "Kompleksi Magnet",
Njësia Lyra 2018_1
Njësia Administrative Nr.7
Tiranë/Albania
E-mail: u.hoxha@vaeku.studio
Tel: +355674088492



APARTAMENTI NR:

38

Objekti Nr :

2

Kati :

3

Orientimi :

JUG

Siperfaqe Apartamenti :

61.0 m²

Ambjente te perbashketa:

6.5 m²

Siperfaqe totale:

67.5 m²



P.T

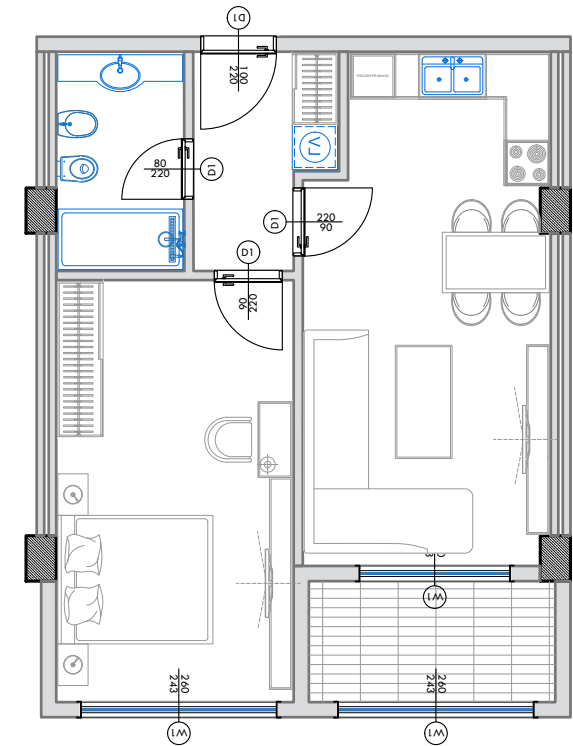
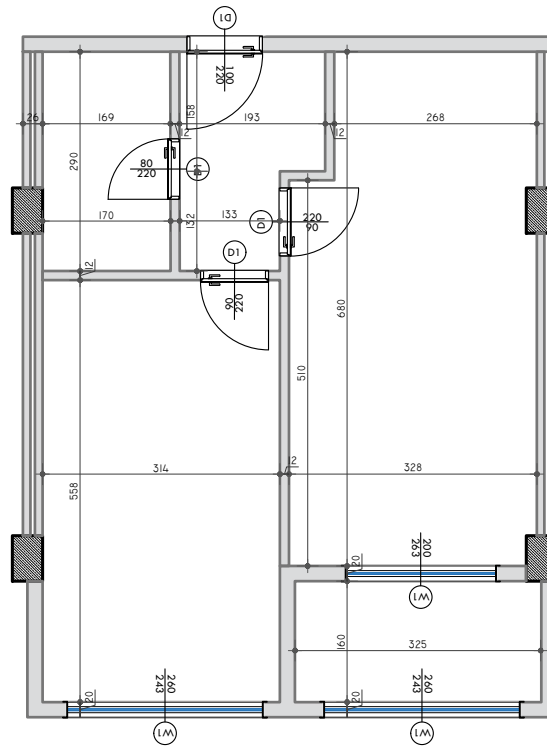

PLANIMETRIA E APARTAMENTIT - PERMASIM

SHKALLA 1:100

PLANIMETRIA E APARTAMENTIT - MOBILIM

SHKALLA 1:100

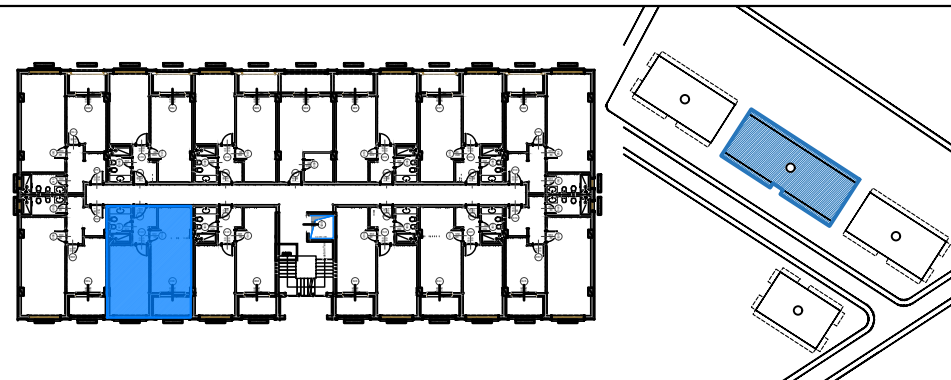

POZICIONI I APARTAMENTIT NE PLANIMETRINE E KATIT



POZICIONI I APARTAMENTIT NE ALTIMETRI - FASADA JUGORE



PAMJE 3 DIMENSIONALE E APARTAMENTIT

NR.1



PAMJE 3 DIMENSIONALE E APARTAMENTIT

NR.2

“4 GODINA BANIMI DHE SHËRBIMI 5 KATE DHE 1 KAT PARKIM NËNTOKË”
Adresa: Pavarsia e Kosovës, Golem - Bashkia Kavajë

INVESTITOR DHE SUBJEKT NDERTUES:

"LOREDIS" Sh.p.k
NIPT: M32202503U
Kavajë / Albania
Tel: +355694080880

PROJEKTUES:

VAEKU STUDIO
NIPT: M11319016N
Adresa: "Kompleksi Magnet",
Njësia Lyra 2018_1
Njësia Administrative Nr.7
Tiranë/Albania
E-mail: u.hoxha@vaeku.studio
Tel: +355674088492



APARTAMENTI NR:

39

Objekti Nr :

2

Kati :

3

Orientimi :

JUG

Siperfaqe Apartamenti :

61.0 m²

Ambjente te perbashketa:

6.5 m²

Siperfaqe totale:

67.5 m²



P.T

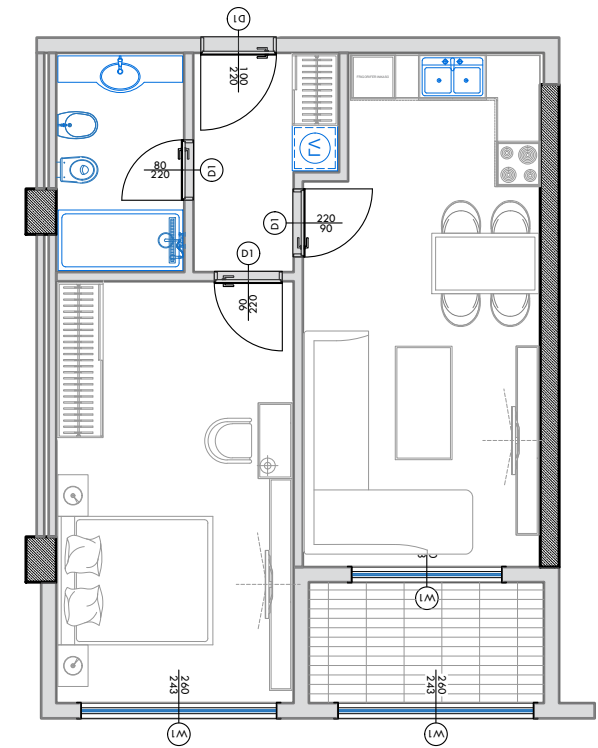
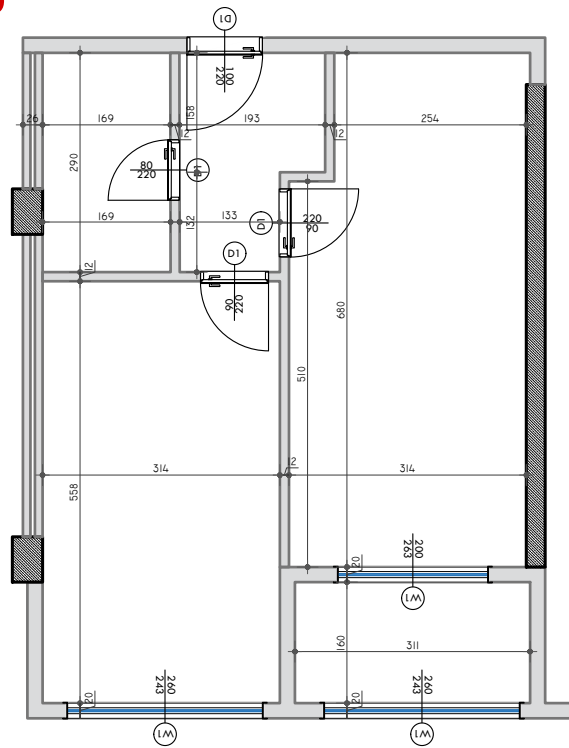

PLANIMETRIA E APARTAMENTIT - PERMASIM

SHKALLA 1:100

PLANIMETRIA E APARTAMENTIT - MOBILIM

SHKALLA 1:100

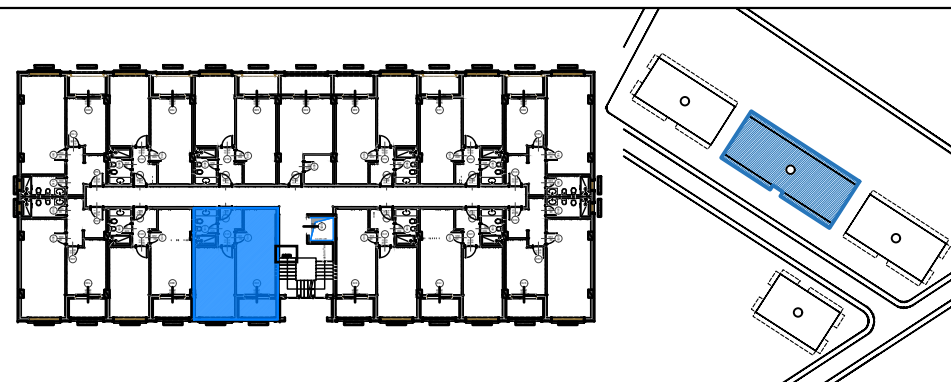

POZICIONI I APARTAMENTIT NE PLANIMETRINE E KATIT



POZICIONI I APARTAMENTIT NE ALTIMETRI - FASADA JUGORE



PAMJE 3 DIMENSIONALE E APARTAMENTIT

NR.1



PAMJE 3 DIMENSIONALE E APARTAMENTIT

NR.2

“4 GODINA BANIMI DHE SHËRBIMI 5 KATE DHE 1 KAT PARKIM NËNTOKË”
Adresa: Pavarsia e Kosovës, Golem - Bashkia Kavajë

INVESTITOR DHE SUBJEKT NDERTUES:

"LOREDIS" Sh.p.k
NIPT: M32202503U
Kavajë / Albania
Tel: +355694080880

PROJEKTUES:

VAEKU STUDIO
NIPT: M11319016N
Adresa: "Kompleksi Magnet",
Njësia Lyra 2018_1
Njësia Administrative Nr.7
Tiranë/Albania
E-mail: u.hoxha@vaeku.studio
Tel: +355674088492



P.T

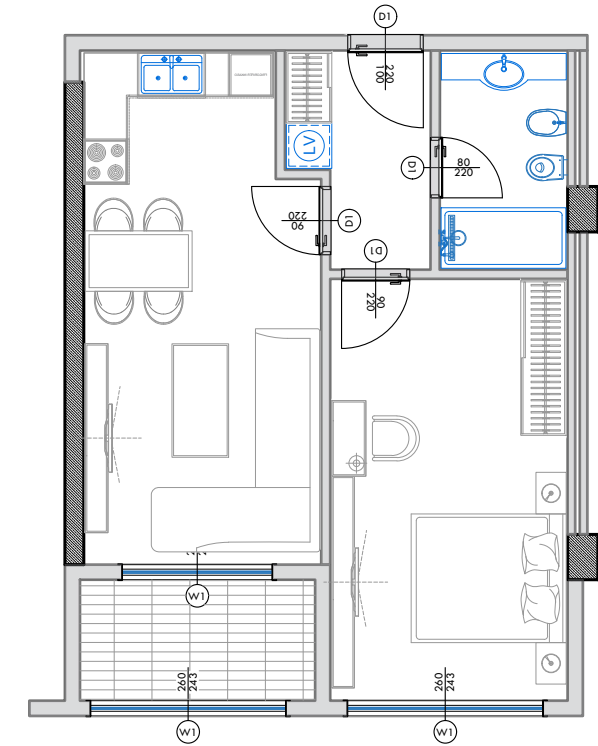
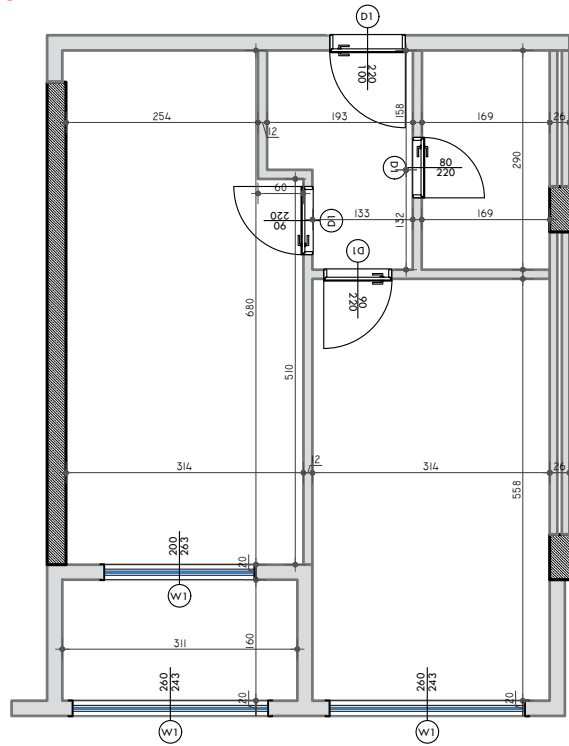

PLANIMETRIA E APARTAMENTIT - PERMASIM

SHKALLA 1:100

PLANIMETRIA E APARTAMENTIT - MOBILIM

SHKALLA 1:100

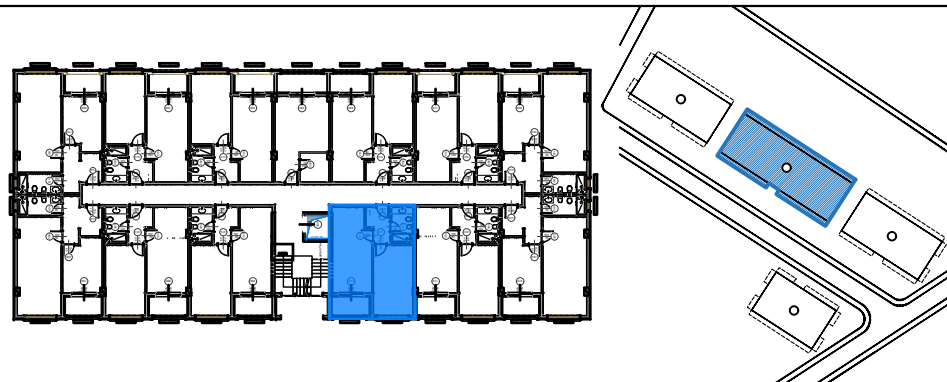

POZICIONI I APARTAMENTIT NE PLANIMETRINE E KATIT



POZICIONI I APARTAMENTIT NE ALTIMETRI - FASADA JUGORE



PAMJE 3 DIMENSIONALE E APARTAMENTIT

NR.1



PAMJE 3 DIMENSIONALE E APARTAMENTIT

NR.2

“4 GODINA BANIMI DHE SHËRBIMI 5 KATE DHE 1 KAT PARKIM NËNTOKË”
Adresa: Pavarsia e Kosovës, Golem - Bashkia Kavajë

INVESTITOR DHE SUBJEKT NDERTUES:

"LOREDIS" Sh.p.k
NIPT: M32202503U
Kavajë / Albania
Tel: +355694080880

PROJEKTUES:

VAEKU STUDIO
NIPT: M11319016N
Adresa: "Kompleksi Magnet",
Njësia Lyra 2018_1
Njësia Administrative Nr.7
Tiranë/Albania
E-mail: u.hoxha@vaeku.studio
Tel: +355674088492



APARTAMENTI NR:

42

Objekti Nr :

2

Kati :

4

Orientimi :

JUG

Siperfaqe Apartamenti :

67.4 m²

Ambjente te perbashketa:

7.2 m²

Siperfaqe totale:

74.6 m²



P.T

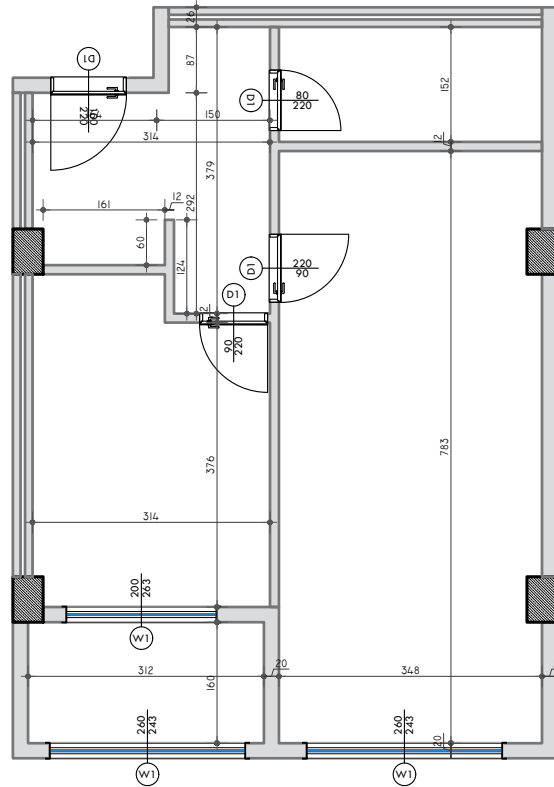

PLANIMETRIA E APARTAMENTIT - PERMASIM

SHKALLA 1:100

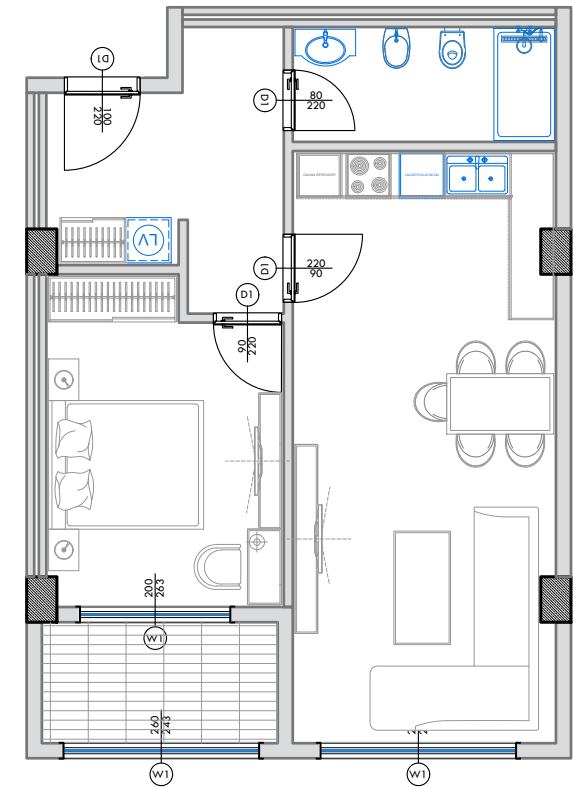

PLANIMETRIA E APARTAMENTIT - MOBILIM

SHKALLA 1:100

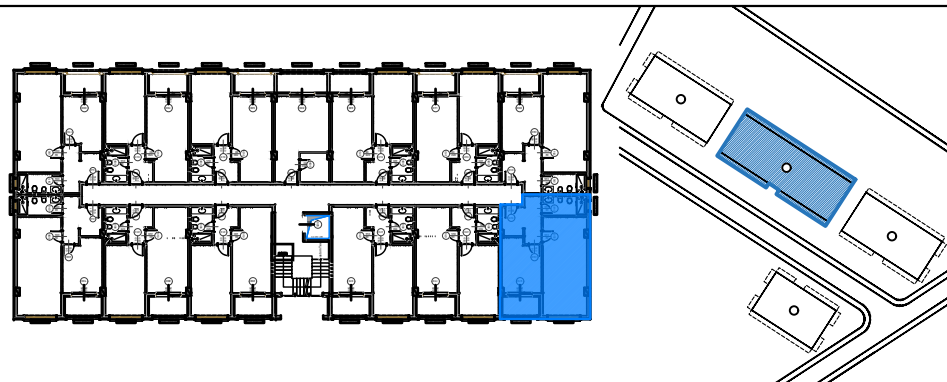

POZICIONI I APARTAMENTIT NE PLANIMETRINE E KATIT



POZICIONI I APARTAMENTIT NE ALTIMETRI - FASADA JUGORE



PAMJE 3 DIMENSIONALE E APARTAMENTIT

NR.1



PAMJE 3 DIMENSIONALE E APARTAMENTIT

NR.2

“4 GODINA BANIMI DHE SHËRBIMI 5 KATE DHE 1 KAT PARKIM NËNTOKË”
Adresa: Pavarsia e Kosovës, Golem - Bashkia Kavajë

INVESTITOR DHE SUBJEKT NDERTUES:

"LOREDIS" Sh.p.k
NIPT: M32202503U
Kavajë / Albania
Tel: +355694080880

PROJEKTUES:

VAEKU STUDIO
NIPT: M11319016N
Adresa: "Kompleksi Magnet",
Njësia Lyra 2018_1
Njësia Administrative Nr.7
Tiranë/Albania
E-mail: u.hoxha@vaeku.studio
Tel: +355674088492



APARTAMENTI NR:

43

Objekti Nr :

2

Kati :

4

Orientimi :

VERI

Siperfaqe Apartamenti :

67.4 m²

Ambjente te perbashketa:

7.2 m²

Siperfaqe totale:

74.6 m²



P.T

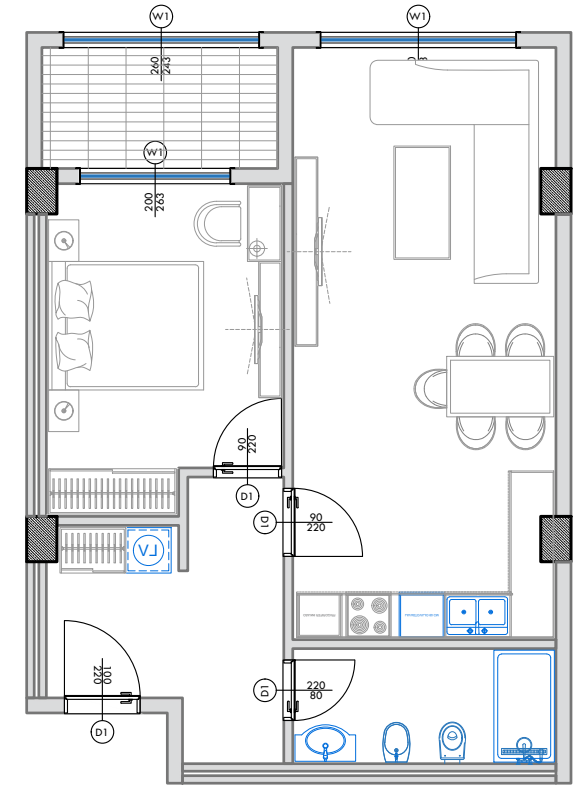
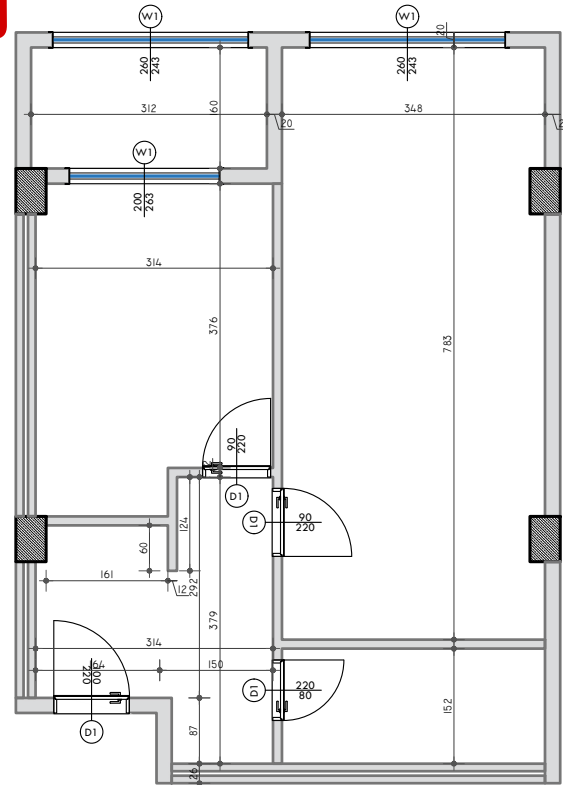

PLANIMETRIA E APARTAMENTIT - PERMASIM

SHKALLA 1:100

PLANIMETRIA E APARTAMENTIT - MOBILIM

SHKALLA 1:100

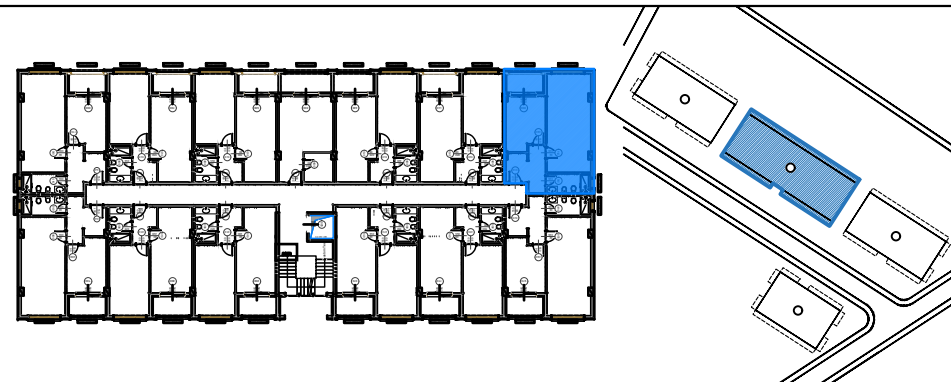

POZICIONI I APARTAMENTIT NE PLANIMETRINE E KATIT



POZICIONI I APARTAMENTIT NE ALTIMETRI - FASADA VERIORE



PAMJE 3 DIMENSIONALE E APARTAMENTIT

NR.1



PAMJE 3 DIMENSIONALE E APARTAMENTIT

NR.2

“4 GODINA BANIMI DHE SHËRBIMI 5 KATE DHE 1 KAT PARKIM NËNTOKË”
Adresa: Pavarsia e Kosovës, Golem - Bashkia Kavajë

INVESTITOR DHE SUBJEKT NDERTUES:

"LOREDIS" Sh.p.k
NIPT: M32202503U
Kavajë / Albania
Tel: +355694080880

PROJEKTUES:

VAEKU STUDIO
NIPT: M11319016N
Adresa: "Kompleksi Magnet",
Njësia Lyra 2018_1
Njësia Administrative Nr.7
Tiranë/Albania
E-mail: u.hoxha@vaeku.studio
Tel: +355674088492



P.T

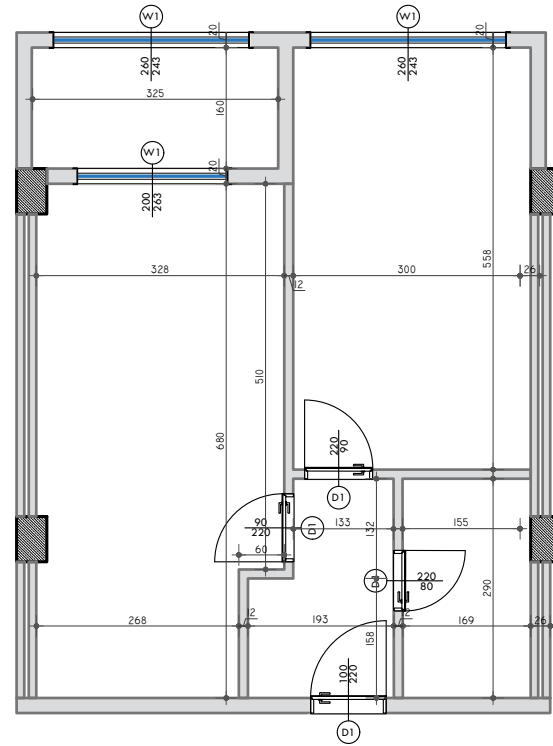

PLANIMETRIA E APARTAMENTIT - PERMASIM

SHKALLA 1:100

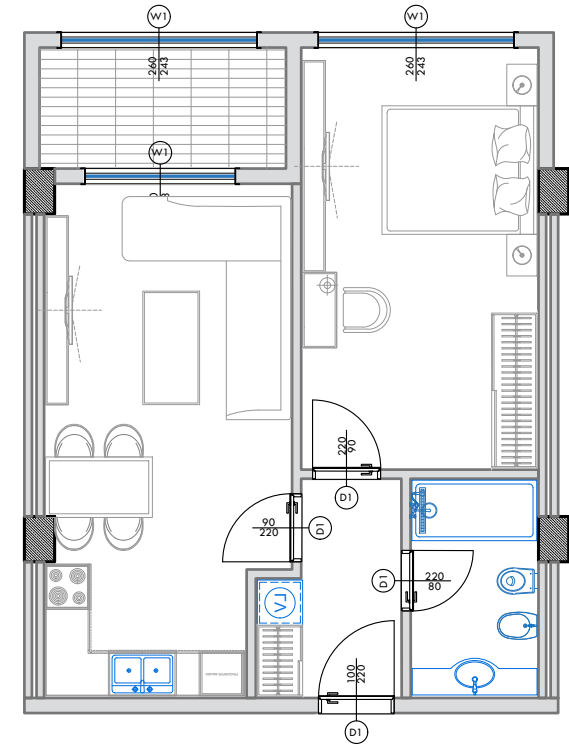

PLANIMETRIA E APARTAMENTIT - MOBILIM

SHKALLA 1:100

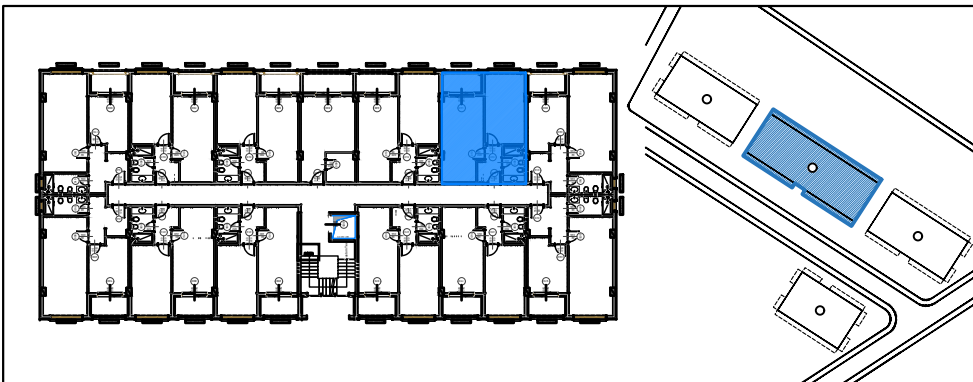

POZICIONI I APARTAMENTIT NE PLANIMETRINE E KATIT



POZICIONI I APARTAMENTIT NE ALTIMETRI - FASADA VERIORE



PAMJE 3 DIMENSIONALE E APARTAMENTIT

NR.1



PAMJE 3 DIMENSIONALE E APARTAMENTIT

NR.2

“4 GODINA BANIMI DHE SHËRBIMI 5 KATE DHE 1 KAT PARKIM NËNTOKË”
Adresa: Pavarsia e Kosovës, Golem - Bashkia Kavajë

INVESTITOR DHE SUBJEKT NDERTUES:

"LOREDIS" Sh.p.k
NIPT: M32202503U
Kavajë / Albania
Tel: +355694080880

PROJEKTUES:

VAEKU STUDIO
NIPT: M11319016N
Adresa: "Kompleksi Magnet",
Njësia Lyra 2018_1
Njësia Administrative Nr.7
Tiranë/Albania
E-mail: u.hoxha@vaeku.studio
Tel: +355674088492



P.T

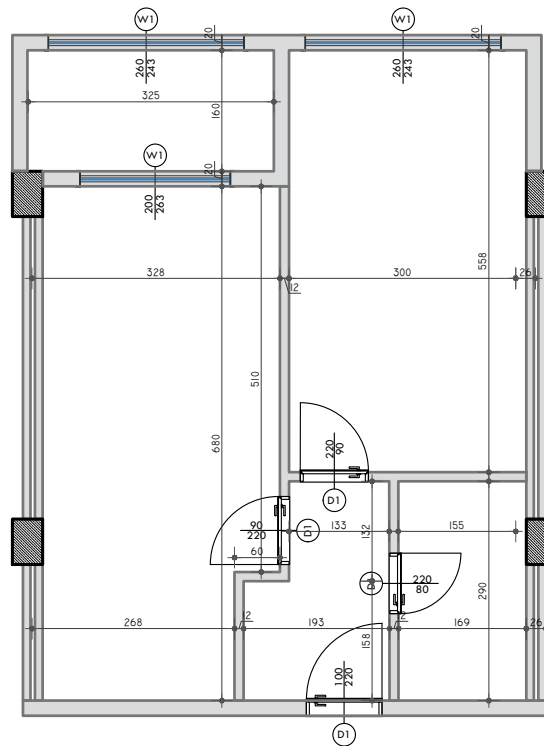

PLANIMETRIA E APARTAMENTIT - PERMASIM

SHKALLA 1:100

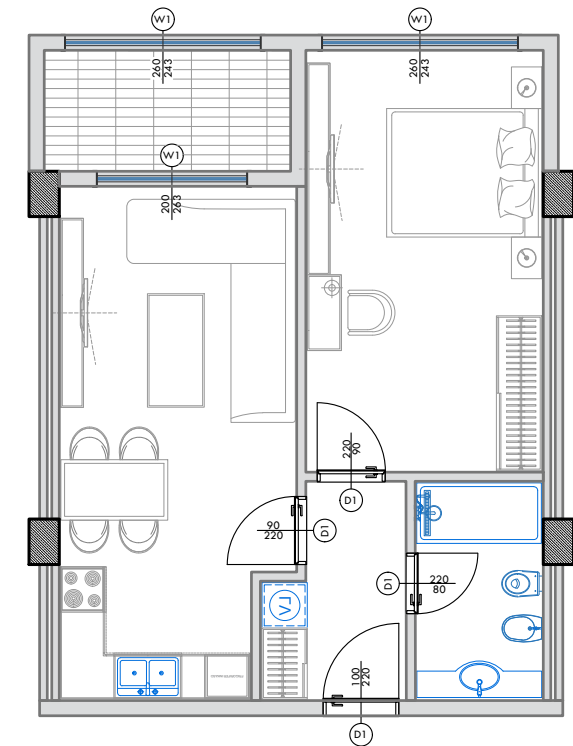

PLANIMETRIA E APARTAMENTIT - MOBILIM

SHKALLA 1:100

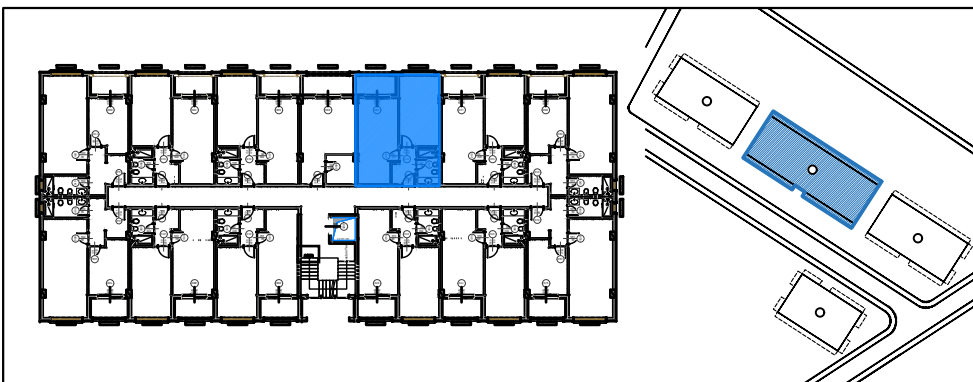

POZICIONI I APARTAMENTIT NE PLANIMETRINE E KATIT



POZICIONI I APARTAMENTIT NE ALTIMETRI - FASADA VERIORE



PAMJE 3 DIMENSIONALE E APARTAMENTIT

NR.1



PAMJE 3 DIMENSIONALE E APARTAMENTIT

NR.2

“4 GODINA BANIMI DHE SHËRBIMI 5 KATE DHE 1 KAT PARKIM NËNTOKË”
Adresa: Pavarsia e Kosovës, Golem - Bashkia Kavajë

INVESTITOR DHE SUBJEKT NDERTUES:

"LOREDIS" Sh.p.k
NIPT: M32202503U
Kavajë / Albania
Tel: +355694080880

PROJEKTUES:

VAEKU STUDIO
NIPT: M11319016N
Adresa: "Kompleksi Magnet",
Njësia Lyra 2018_1
Njësia Administrative Nr.7
Tiranë/Albania
E-mail: u.hoxha@vaeku.studio
Tel: +355674088492



P.T

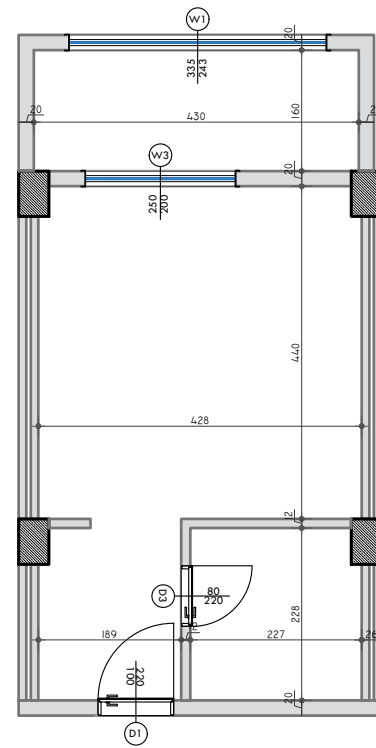

PLANIMETRIA E APARTAMENTIT - PERMASIM

SHKALLA 1:100

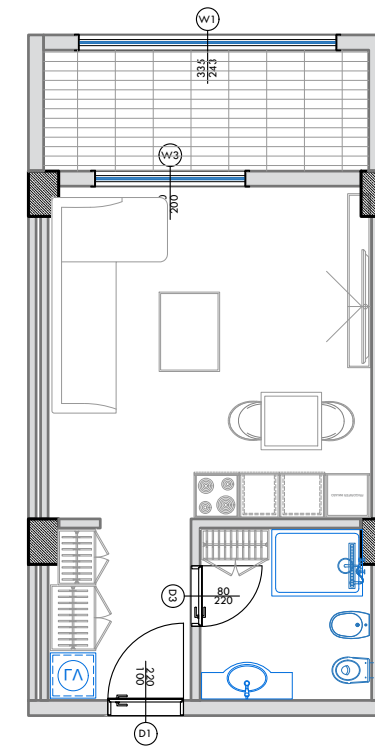

PLANIMETRIA E APARTAMENTIT - MOBILIM

SHKALLA 1:100

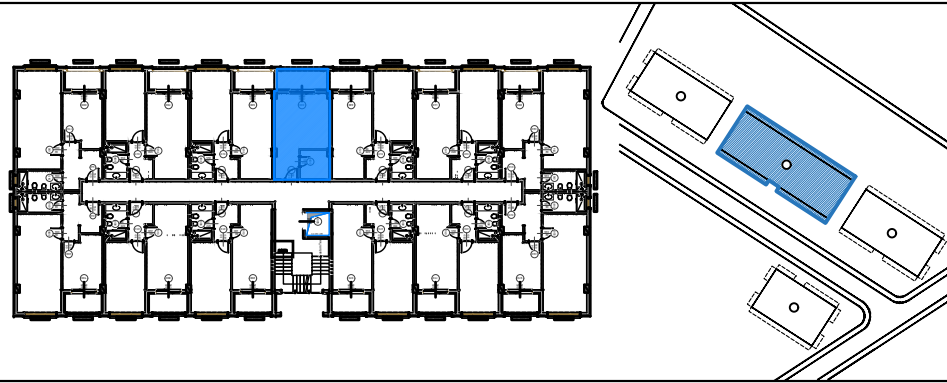

POZICIONI I APARTAMENTIT NE PLANIMETRINE E KATIT

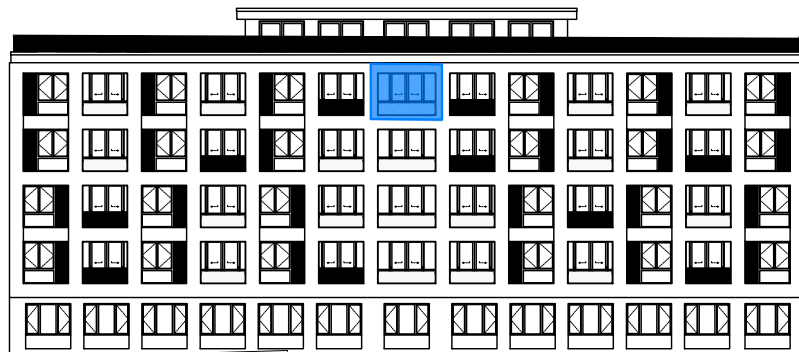

POZICIONI I APARTAMENTIT NE ALTIMETRI - FASADA VERIORE



PAMJE 3 DIMENSIONALE E APARTAMENTIT

NR.1



PAMJE 3 DIMENSIONALE E APARTAMENTIT

NR.2

“4 GODINA BANIMI DHE SHËRBIMI 5 KATE DHE 1 KAT PARKIM NËNTOKË”
Adresa: Pavarsia e Kosovës, Golem - Bashkia Kavajë

INVESTITOR DHE SUBJEKT NDERTUES:

"LOREDIS" Sh.p.k
NIPT: M32202503U
Kavajë / Albania
Tel: +355694080880

PROJEKTUES:

VAEKU STUDIO
NIPT: M11319016N
Adresa: "Kompleksi Magnet",
Njësia Lyra 2018_1
Njësia Administrative Nr.7
Tiranë/Albania
E-mail: u.hoxha@vaeku.studio
Tel: +355674088492



P.T

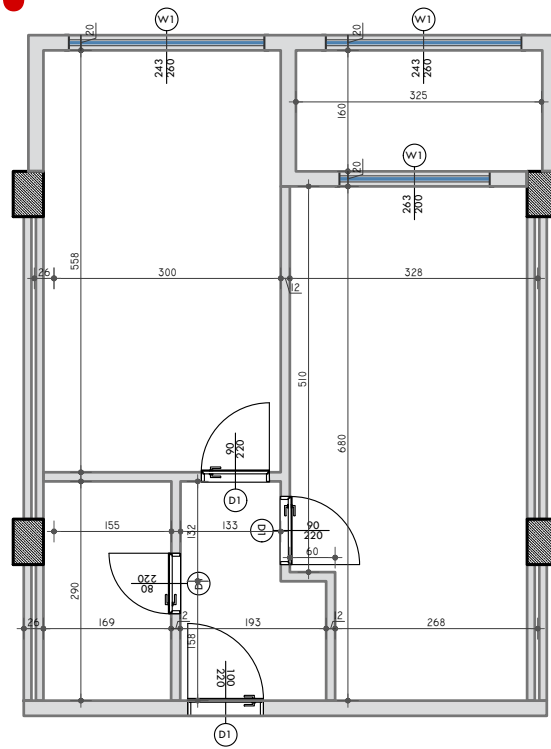

PLANIMETRIA E APARTAMENTIT - PERMASIM

SHKALLA 1:100

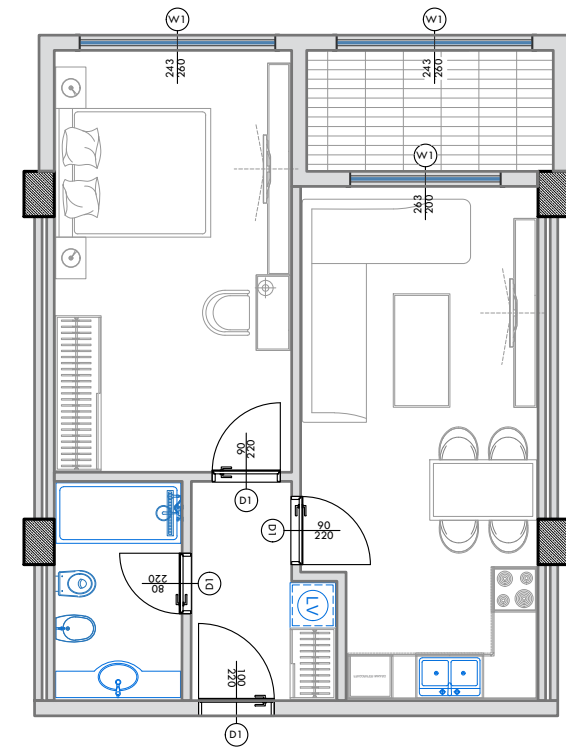

PLANIMETRIA E APARTAMENTIT - MOBILIM

SHKALLA 1:100

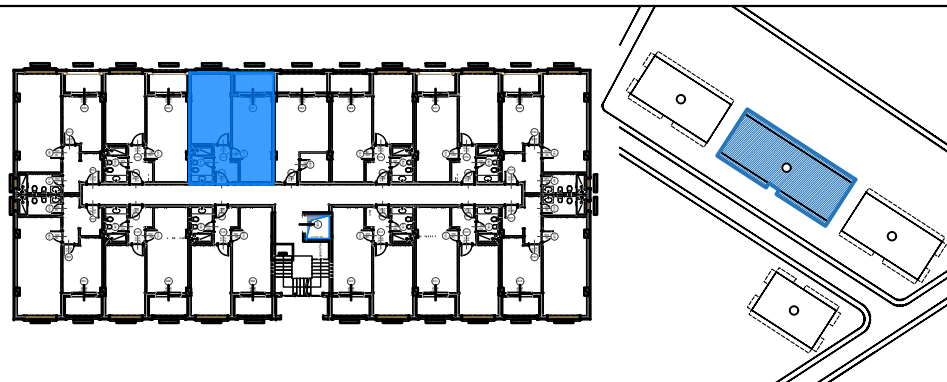

POZICIONI I APARTAMENTIT NE PLANIMETRINE E KATIT



POZICIONI I APARTAMENTIT NE ALTIMETRI - FASADA VERIORE



PAMJE 3 DIMENSIONALE E APARTAMENTIT

NR.1



PAMJE 3 DIMENSIONALE E APARTAMENTIT

NR.2

“4 GODINA BANIMI DHE SHËRBIMI 5 KATE DHE 1 KAT PARKIM NËNTOKË”
Adresa: Pavarsia e Kosovës, Golem - Bashkia Kavajë

INVESTITOR DHE SUBJEKT NDERTUES:

"LOREDIS" Sh.p.k
NIPT: M32202503U
Kavajë / Albania
Tel: +355694080880

PROJEKTUES:

VAEKU STUDIO
NIPT: M11319016N
Adresa: "Kompleksi Magnet",
Njësia Lyra 2018_1
Njësia Administrative Nr.7
Tiranë/Albania
E-mail: u.hoxha@vaeku.studio
Tel: +355674088492



APARTAMENTI NR:

48

Objekti Nr :

2

Kati :

4

Orientimi :

VERI

Siperfaqe Apartamenti :

61.0m²

Ambjente te perbashketa:

6.5 m²

Siperfaqe totale:

67.5 m²



P.T

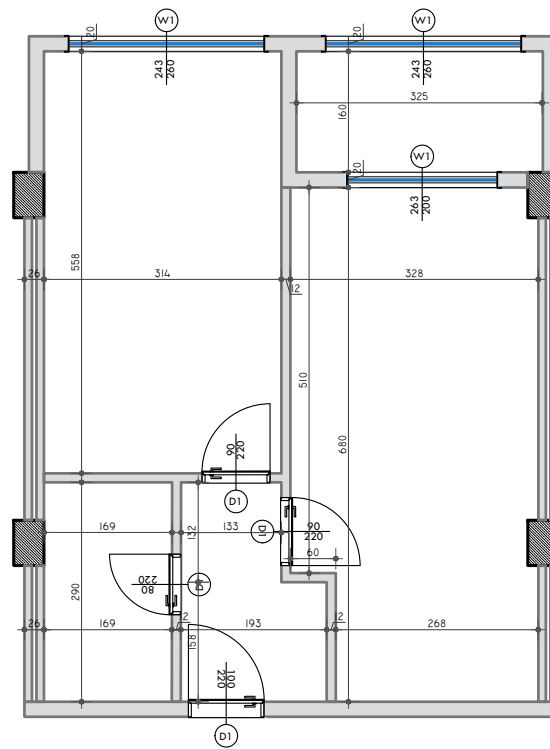

PLANIMETRIA E APARTAMENTIT - PERMASIM

SHKALLA 1:100

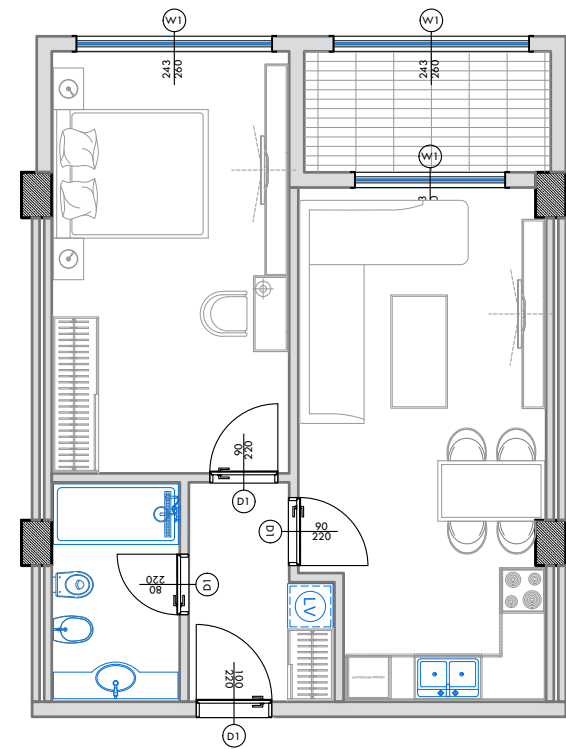

PLANIMETRIA E APARTAMENTIT - MOBILIM

SHKALLA 1:100

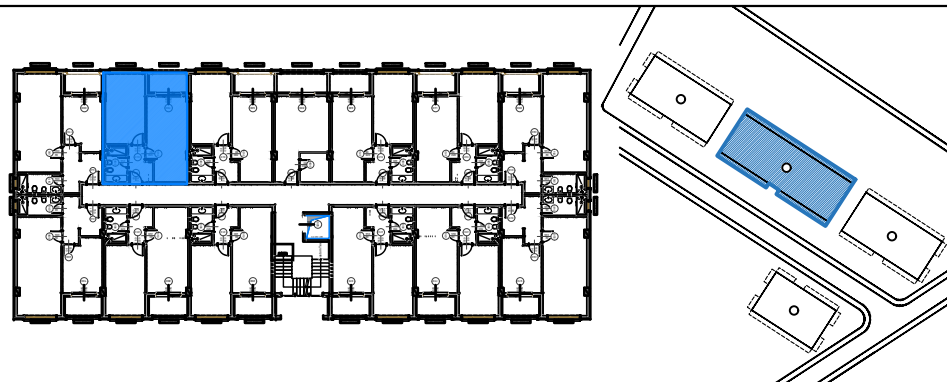

POZICIONI I APARTAMENTIT NE PLANIMETRINE E KATIT



POZICIONI I APARTAMENTIT NE ALTIMETRI - FASADA VERIORE



PAMJE 3 DIMENSIONALE E APARTAMENTIT

NR.1



PAMJE 3 DIMENSIONALE E APARTAMENTIT

NR.2

“4 GODINA BANIMI DHE SHËRBIMI 5 KATE DHE 1 KAT PARKIM NËNTOKË”
Adresa: Pavarsia e Kosovës, Golem - Bashkia Kavajë

INVESTITOR DHE SUBJEKT NDERTUES:

"LOREDIS" Sh.p.k
NIPT: M32202503U
Kavajë / Albania
Tel: +355694080880

PROJEKTUES:

VAEKU STUDIO
NIPT: M11319016N
Adresa: "Kompleksi Magnet",
Njësia Lyra 2018_1
Njësia Administrative Nr.7
Tiranë/Albania
E-mail: u.hoxha@vaeku.studio
Tel: +355674088492



APARTAMENTI NR:

50

Objekti Nr :

2

Kati :

4

Orientimi :

JUG

Siperfaqe Apartamenti :

67.4 m²

Ambjente te perbashketa:

7.2 m²

Siperfaqe totale:

74.6 m²



P.T

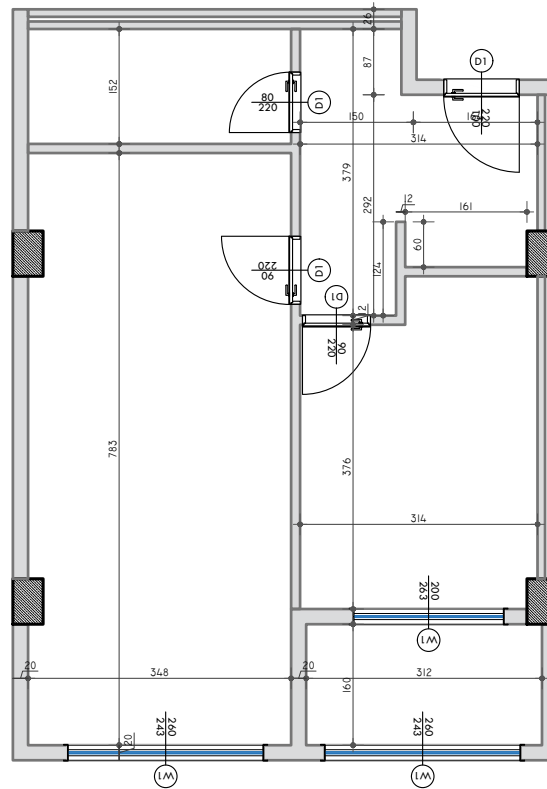

PLANIMETRIA E APARTAMENTIT - PERMASIM

SHKALLA 1:100

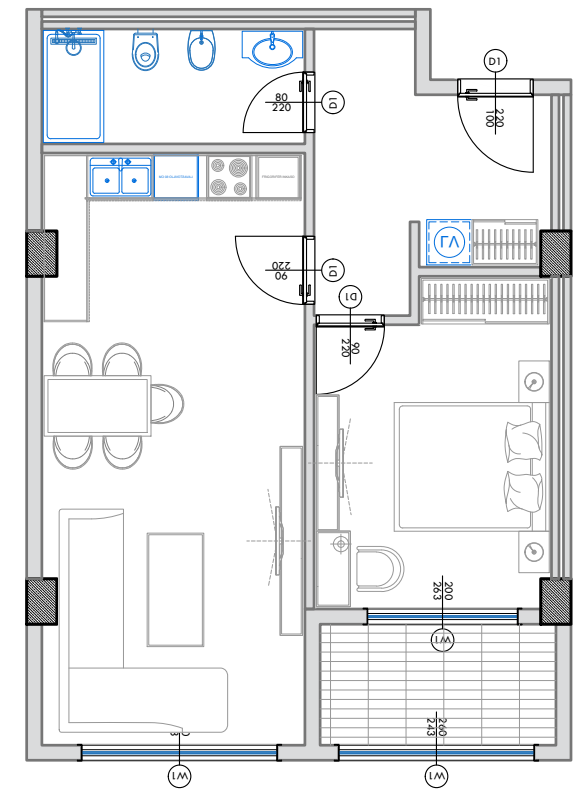

PLANIMETRIA E APARTAMENTIT - MOBILIM

SHKALLA 1:100

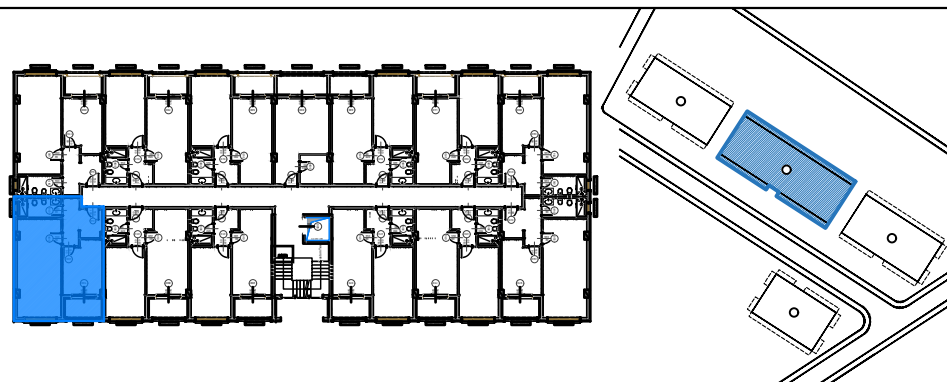

POZICIONI I APARTAMENTIT NE PLANIMETRINE E KATIT



POZICIONI I APARTAMENTIT NE ALTIMETRI - FASADA JUGORE



PAMJE 3 DIMENSIONALE E APARTAMENTIT

NR.1



PAMJE 3 DIMENSIONALE E APARTAMENTIT

NR.2

“4 GODINA BANIMI DHE SHËRBIMI 5 KATE DHE 1 KAT PARKIM NËNTOKË”
Adresa: Pavarsia e Kosovës, Golem - Bashkia Kavajë

INVESTITOR DHE SUBJEKT NDERTUES:

“LOREDIS” Sh.p.k
NIPT: M32202503U
Kavajë / Albania
Tel: +355694080880

PROJEKTUES:

VAEKU STUDIO
NIPT: M11319016N
Adresa: “Kompleksi Magnet”,
Njësia Lyra 2018_1
Njësia Administrative Nr.7
Tiranë/Albania
E-mail: u.hoxha@vaeku.studio
Tel: +355674088492



P.T

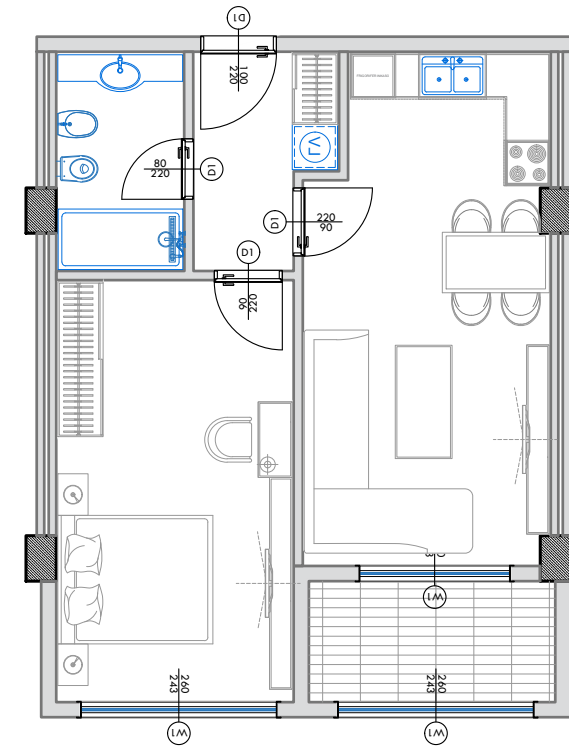
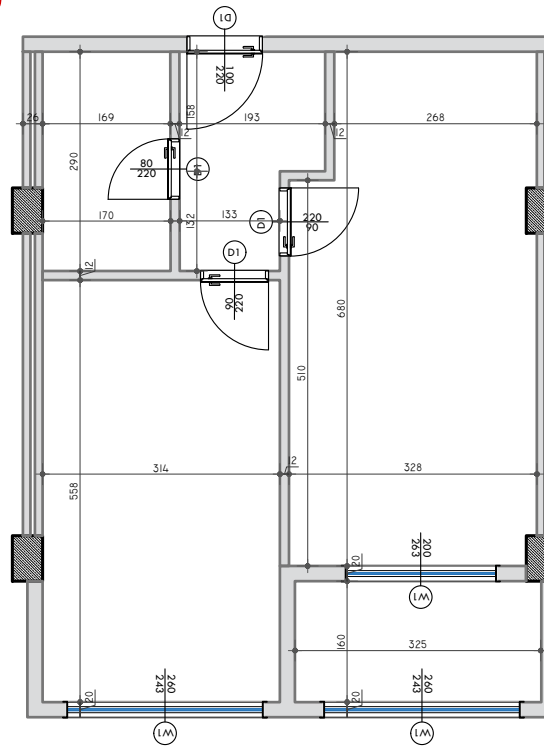

APARTAMENTI NR:	51
Objekti Nr :	2
Kati :	4
Orientimi :	JUG
Siperfaqe Apartamenti :	61.0 m ²
Ambjente te perbashketa:	6.5 m ²
Siperfaqe totale:	67.5 m ²



PLANIMETRIA E APARTAMENTIT - PERMASIM

SHKALLA 1:100

PLANIMETRIA E APARTAMENTIT - MOBILIM

SHKALLA 1:100

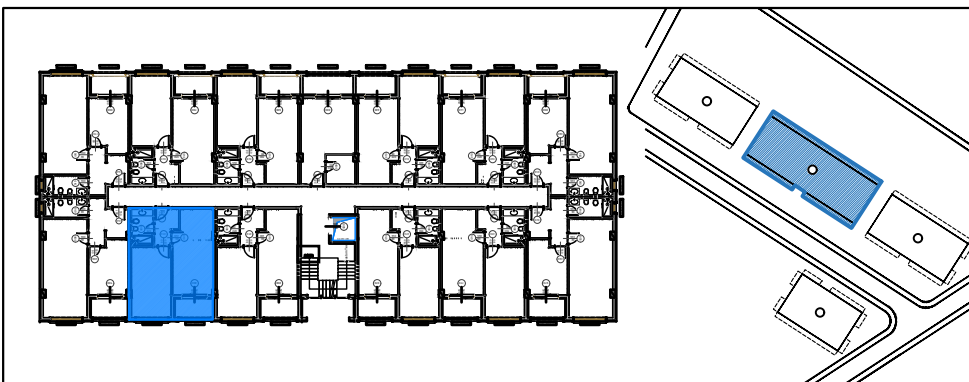

POZICIONI I APARTAMENTIT NE PLANIMETRINE E KATIT



POZICIONI I APARTAMENTIT NE ALTIMETRI - FASADA JUGORE



PAMJE 3 DIMENSIONALE E APARTAMENTIT

NR.1



PAMJE 3 DIMENSIONALE E APARTAMENTIT

NR.2

“4 GODINA BANIMI DHE SHËRBIMI 5 KATE DHE 1 KAT PARKIM NËNTOKË”
Adresa: Pavarsia e Kosovës, Golem - Bashkia Kavajë

INVESTITOR DHE SUBJEKT NDERTUES:

"LOREDIS" Sh.p.k
NIPT: M32202503U
Kavajë / Albania
Tel: +355694080880

PROJEKTUES:

VAEKU STUDIO
NIPT: M11319016N
Adresa: "Kompleksi Magnet",
Njësia Lyra 2018_1
Njësia Administrative Nr.7
Tiranë/Albania
E-mail: u.hoxha@vaeku.studio
Tel: +355674088492



P.T

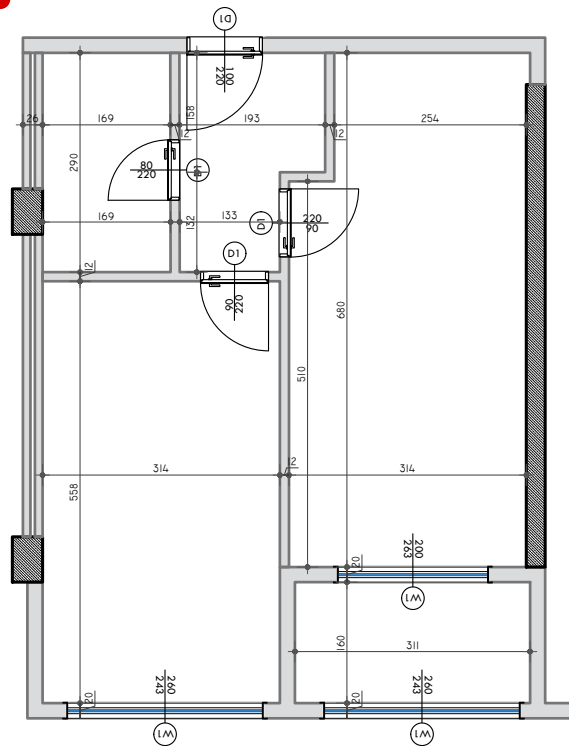

PLANIMETRIA E APARTAMENTIT - PERMASIM

SHKALLA 1:100

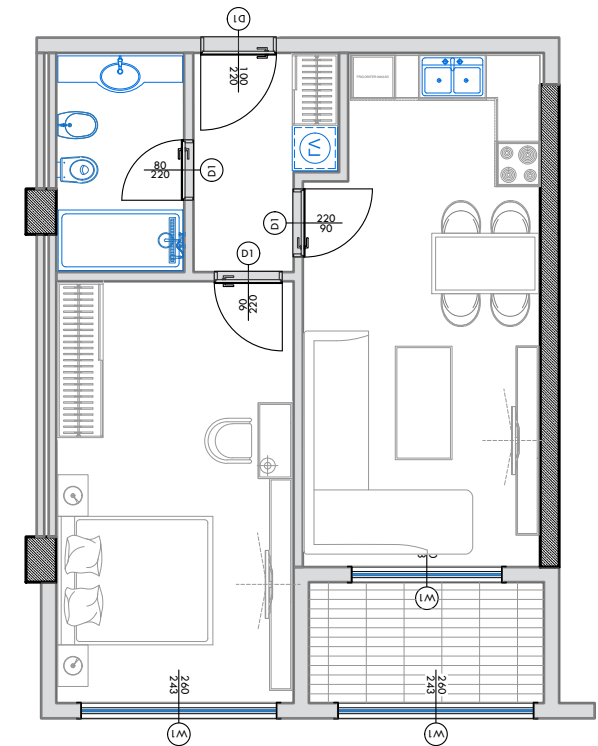

PLANIMETRIA E APARTAMENTIT - MOBILIM

SHKALLA 1:100

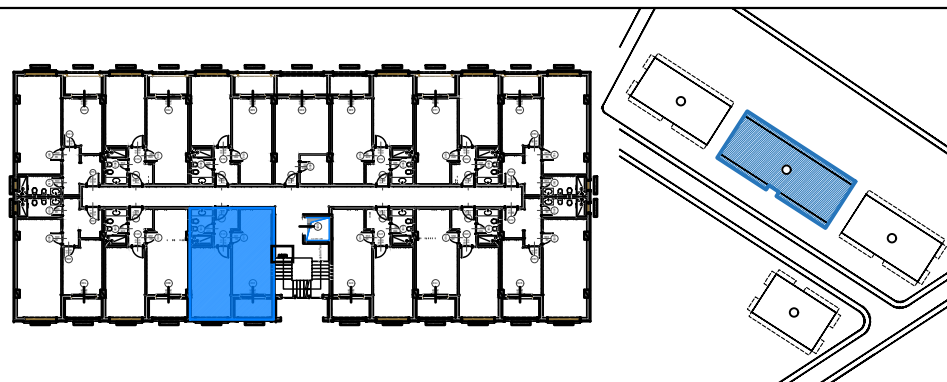

POZICIONI I APARTAMENTIT NE PLANIMETRINE E KATIT



POZICIONI I APARTAMENTIT NE ALTIMETRI - FASADA JUGORE



PAMJE 3 DIMENSIONALE E APARTAMENTIT

NR.1



PAMJE 3 DIMENSIONALE E APARTAMENTIT

NR.2