

# ALBUM

# SHITJESH

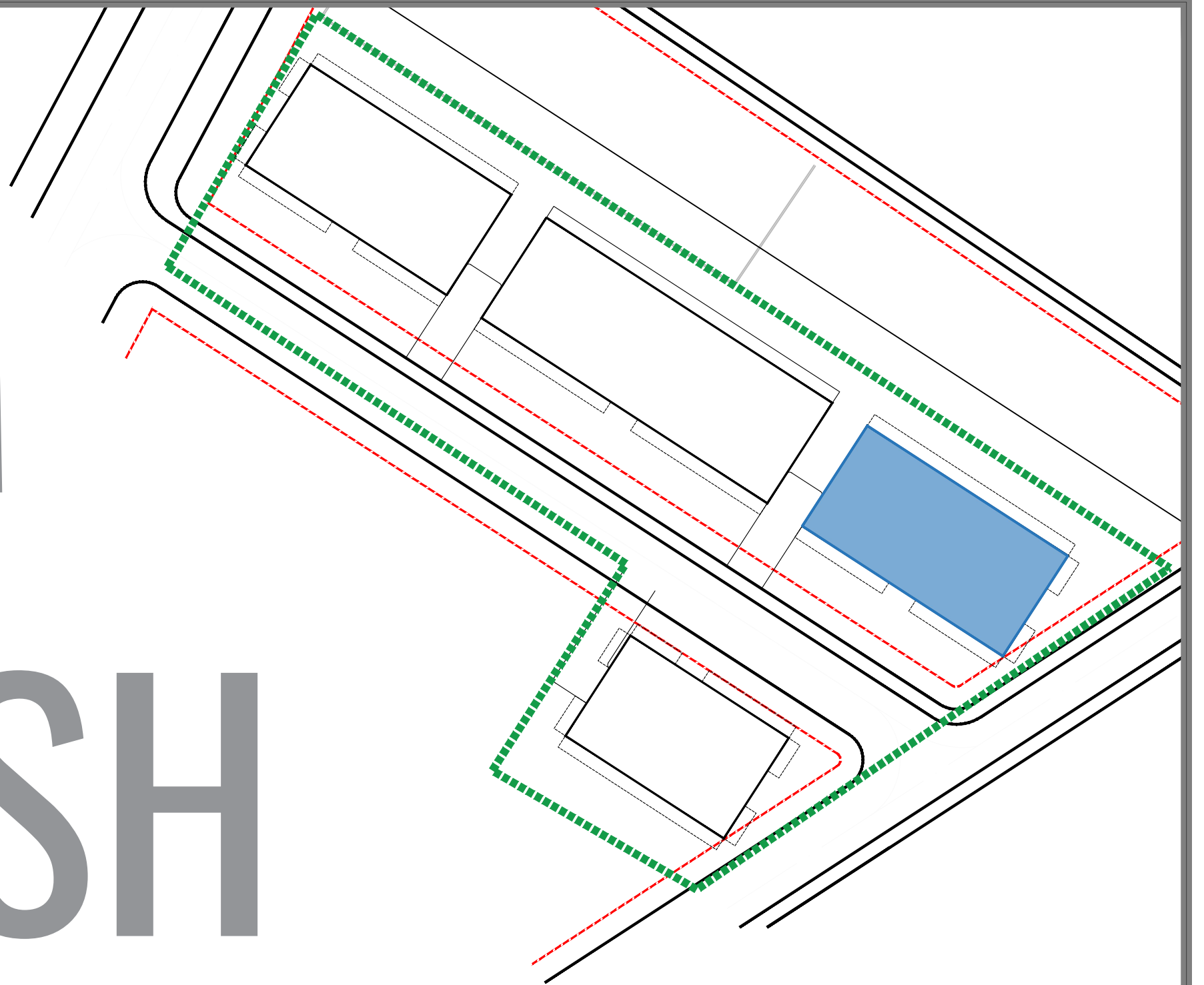

**“4 GODINA BANIMI DHE SHËRBIMI 5 KATE DHE 1 KAT PARKIM NËNTOKË”**

## OBJEKTI 3

**“4 GODINA BANIMI DHE SHËRBIMI 5 KATE DHE 1 KAT PARKIM NËNTOKË”**  
**Adresa: Pavarsia e Kosovës, Golem - Bashkia Kavajë**

**INVESTITOR DHE SUBJEKT NDERTUES:**

**"LOREDIS" Sh.p.k**  
**NIPT: M32202503U**  
**Kavajë / Albania**  
**Tel: +355694080880**

**PROJEKTUES:**

**VAEKU STUDIO**  
**NIPT: M11319016N**  
**Adresa: "Kompleksi Magnet",**  
**Njësia Lyra 2018\_1**  
**Njësia Administrative Nr.7**  
**Tiranë/Albania**  
**E-mail: u.hoxha@vaeu.studio**  
**Tel: +355674088492**



**APARTAMENTI NR:**

**P1**

**Objekti Nr :**

**3**

**Kati :**

**0**

**Orientimi :**

**JUG**

**Siperfaqe Apartamenti :**

**49.0 m<sup>2</sup>**

**Ambjente te perbashketa:**

**5.3 m<sup>2</sup>**

**Siperfaqe totale:**

**54.3 m<sup>2</sup>**

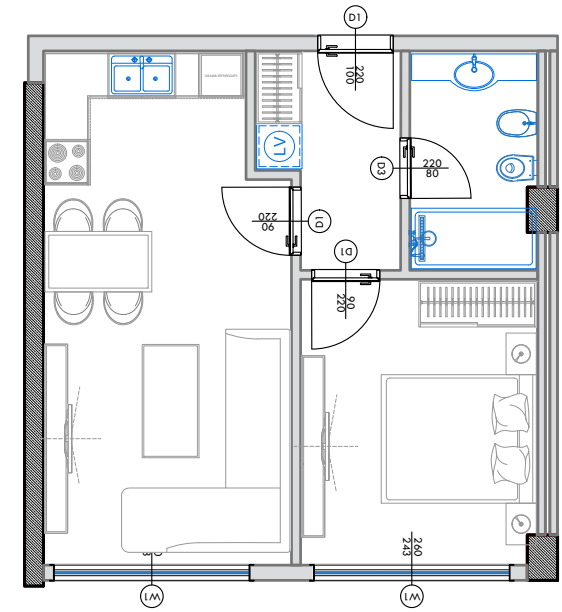
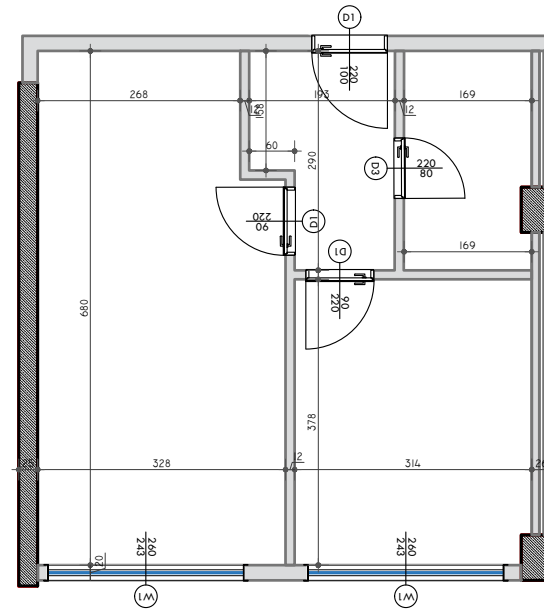

**PLANIMETRIA E APARTAMENTIT - PERMASIM**

**SHKALLA 1:100**

**PLANIMETRIA E APARTAMENTIT - MOBILIM**

**SHKALLA 1:100**

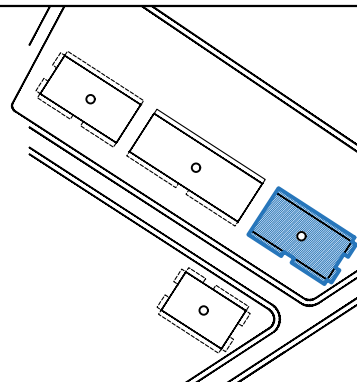

**POZICIONI I APARTAMENTIT NE PLANIMETRINE E KATIT**



**POZICIONI I APARTAMENTIT NE ALTIMETRI - FASADA JUGORE**



**PAMJE 3 DIMENSIONALE E APARTAMENTIT**

**NR.1**



**PAMJE 3 DIMENSIONALE E APARTAMENTIT**

**NR.2**

**“4 GODINA BANIMI DHE SHËRBIMI 5 KATE DHE 1 KAT PARKIM NËNTOKË”**  
**Adresa: Pavarsia e Kosovës, Golem - Bashkia Kavajë**

**INVESTITOR DHE SUBJEKT NDERTUES:**

**"LOREDIS" Sh.p.k**  
**NIPT: M32202503U**  
**Kavajë / Albania**  
**Tel: +355694080880**

**PROJEKTUES:**

**VAEKU STUDIO**  
**NIPT: M11319016N**  
**Adresa: "Kompleksi Magnet",**  
**Njësia Lyra 2018\_1**  
**Njësia Administrative Nr.7**  
**Tiranë/Albania**  
**E-mail: u.hoxha@vaeku.studio**  
**Tel: +355674088492**



**APARTAMENTI NR:**

**P2**

**Objekti Nr :**

**3**

**Kati :**

**0**

**Orientimi :**

**JUG**

**Siperfaqe Apartamenti :**

**55.2 m<sup>2</sup>**

**Ambjente te perbashketa:**

**5.9 m<sup>2</sup>**

**Siperfaqe totale:**

**61.1 m<sup>2</sup>**

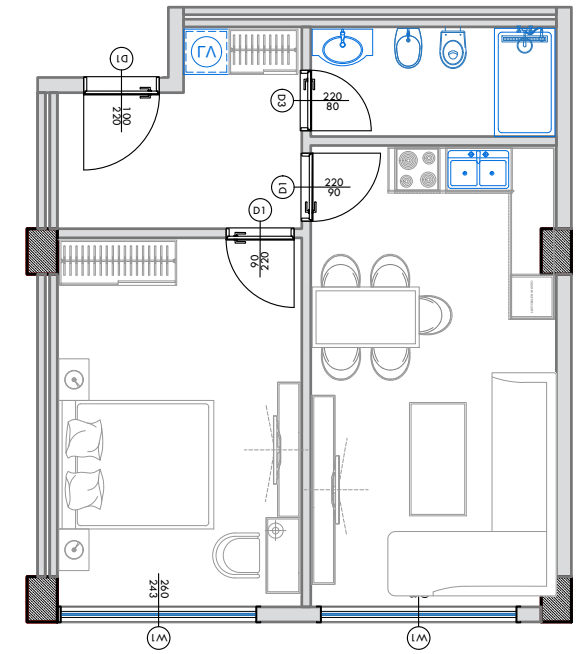
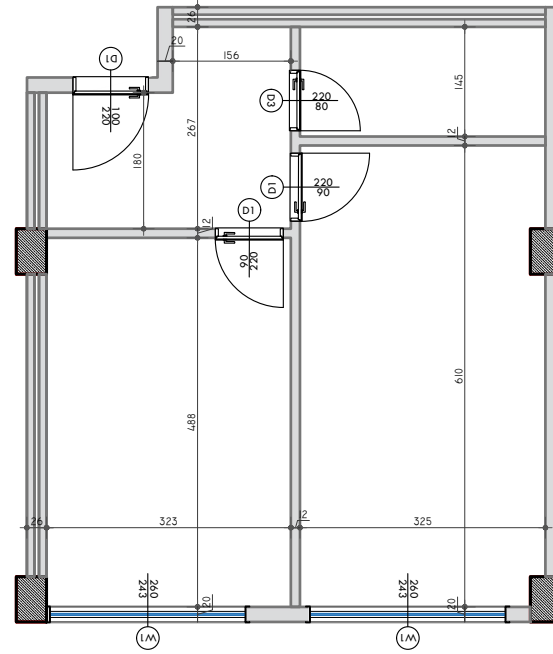

**PLANIMETRIA E APARTAMENTIT - PERMASIM**

**SHKALLA 1:100**

**PLANIMETRIA E APARTAMENTIT - MOBILIM**

**SHKALLA 1:100**

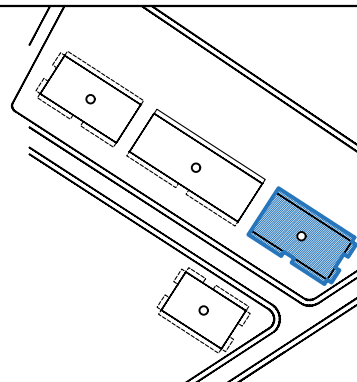

**POZICIONI I APARTAMENTIT NE PLANIMETRINE E KATIT**



**POZICIONI I APARTAMENTIT NE ALTIMETRI - FASADA JUGORE**

**PAMJE 3 DIMENSIONALE E APARTAMENTIT**

**NR.1**

**PAMJE 3 DIMENSIONALE E APARTAMENTIT**

**NR.2**

**“4 GODINA BANIMI DHE SHËRBIMI 5 KATE DHE 1 KAT PARKIM NËNTOKË”**  
**Adresa: Pavarsia e Kosovës, Golem - Bashkia Kavajë**

**INVESTITOR DHE SUBJEKT NDERTUES:**

**"LOREDIS" Sh.p.k**  
**NIPT: M32202503U**  
**Kavajë / Albania**  
**Tel: +355694080880**

**PROJKTUES:**

**VAEKU STUDIO**  
**NIPT: M11319016N**  
**Adresa: "Kompleksi Magnet",**  
**Njësia Lyra 2018\_1**  
**Njësia Administrative Nr.7**  
**Tiranë/Albania**  
**E-mail: u.hoxha@vaeku.studio**  
**Tel: +355674088492**



**APARTAMENTI NR:**

**P3**

**Objekti Nr :**

**3**

**Kati :**

**0**

**Orientimi :**

**VERI**

**Siperfaqe Apartamenti :**

**55.2 m<sup>2</sup>**

**Ambjente te perbashketa:**

**5.9 m<sup>2</sup>**

**Siperfaqe totale:**

**61.1 m<sup>2</sup>**

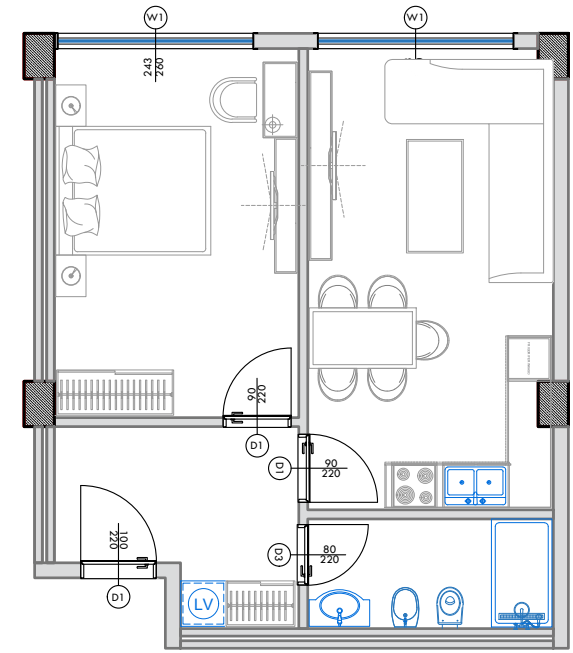
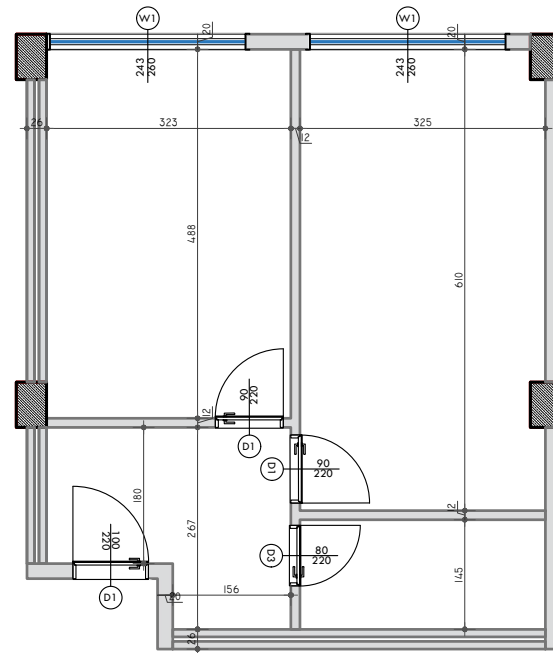

**PLANIMETRIA E APARTAMENTIT - PERMASIM**

**SHKALLA 1:100**

**PLANIMETRIA E APARTAMENTIT - MOBILIM**

**SHKALLA 1:100**

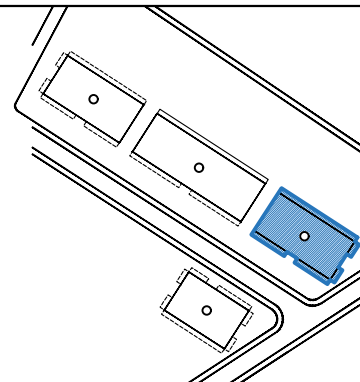

**POZICIONI I APARTAMENTIT NE PLANIMETRINE E KATIT**

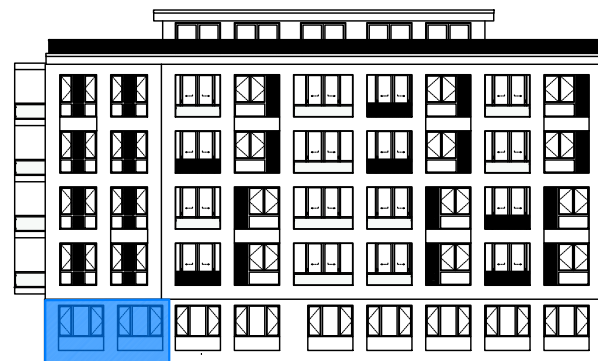

**POZICIONI I APARTAMENTIT NE ALTIMETRI - FASADA VERIORE**



**PAMJE 3 DIMENSIONALE E APARTAMENTIT**

**NR.1**



**PAMJE 3 DIMENSIONALE E APARTAMENTIT**

**NR.2**

**“4 GODINA BANIMI DHE SHËRBIMI 5 KATE DHE 1 KAT PARKIM NËNTOKË”**  
**Adresa: Pavarsia e Kosovës, Golem - Bashkia Kavajë**

**INVESTITOR DHE SUBJEKT NDERTUES:**

**"LOREDIS" Sh.p.k**  
**NIPT: M32202503U**  
**Kavajë / Albania**  
**Tel: +355694080880**

**PROJEKTUES:**

**VAEKU STUDIO**  
**NIPT: M11319016N**  
**Adresa: "Kompleksi Magnet",**  
**Njësia Lyra 2018\_1**  
**Njësia Administrative Nr.7**  
**Tiranë/Albania**  
**E-mail: u.hoxha@vaeku.studio**  
**Tel: +355674088492**



**APARTAMENTI NR:**

**P4**

**Objekti Nr :**

**3**

**Kati :**

**0**

**Orientimi :**

**VERI**

**Siperfaqe Apartamenti :**

**49.0 m<sup>2</sup>**

**Ambjente te perbashketa:**

**5.3 m<sup>2</sup>**

**Siperfaqe totale:**

**54.3 m<sup>2</sup>**

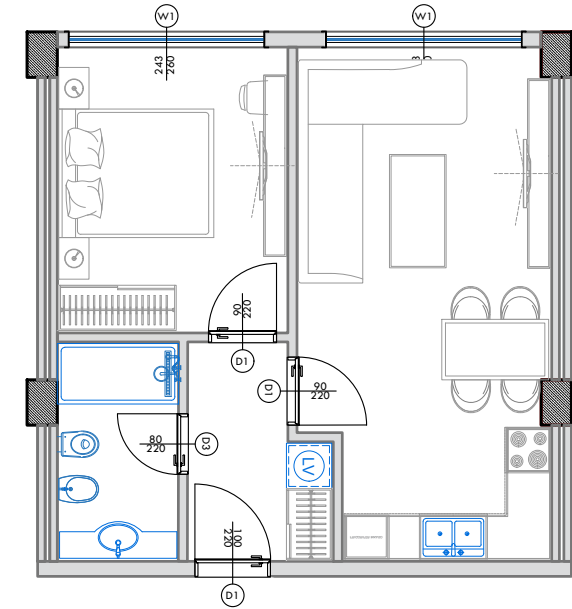
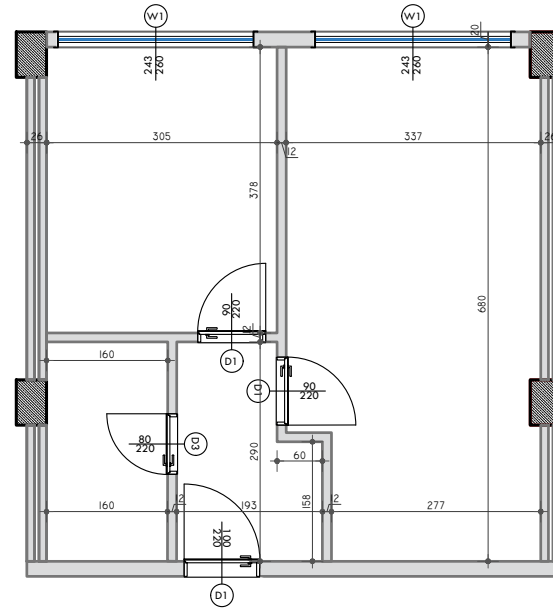

**PLANIMETRIA E APARTAMENTIT - PERMASIM**

**SHKALLA 1:100**

**PLANIMETRIA E APARTAMENTIT - MOBILIM**

**SHKALLA 1:100**

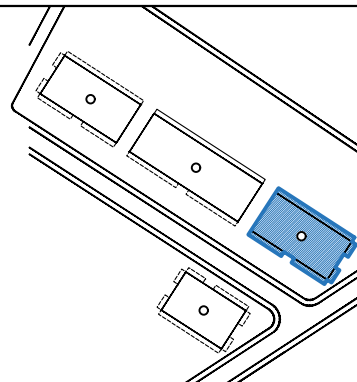

**POZICIONI I APARTAMENTIT NE PLANIMETRINE E KATIT**

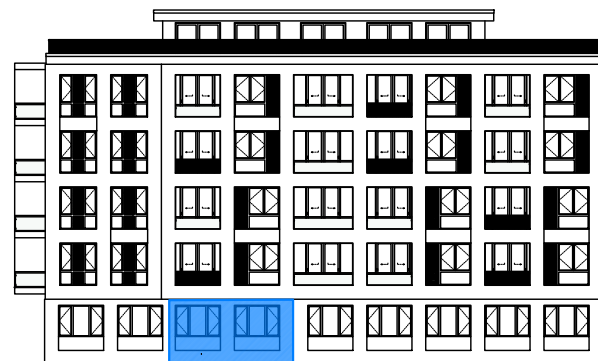

**POZICIONI I APARTAMENTIT NE ALTIMETRI - FASADA VERIORE**



**PAMJE 3 DIMENSIONALE E APARTAMENTIT**

**NR.1**



**PAMJE 3 DIMENSIONALE E APARTAMENTIT**

**NR.2**



**“4 GODINA BANIMI DHE SHËRBIMI 5 KATE DHE 1 KAT PARKIM NËNTOKË”**  
**Adresa: Pavarsia e Kosovës, Golem - Bashkia Kavajë**

**INVESTITOR DHE SUBJEKT NDERTUES:**

**"LOREDIS" Sh.p.k**  
**NIPT: M32202503U**  
**Kavajë / Albania**  
**Tel: +355694080880**

**PROJEKTUES:**

**VAEKU STUDIO**  
**NIPT: M11319016N**  
**Adresa: "Kompleksi Magnet",**  
**Njësia Lyra 2018\_1**  
**Njësia Administrative Nr.7**  
**Tiranë/Albania**  
**E-mail: u.hoxha@vaeuku.studio**  
**Tel: +355674088492**



**APARTAMENTI NR:**

**P6**

**Objekti Nr :**

**3**

**Kati :**

**0**

**Orientimi :**

**VERI**

**Siperfaqe Apartamenti :**

**49.0 m<sup>2</sup>**

**Ambjente te perbashketa:**

**5.3 m<sup>2</sup>**

**Siperfaqe totale:**

**54.3 m<sup>2</sup>**

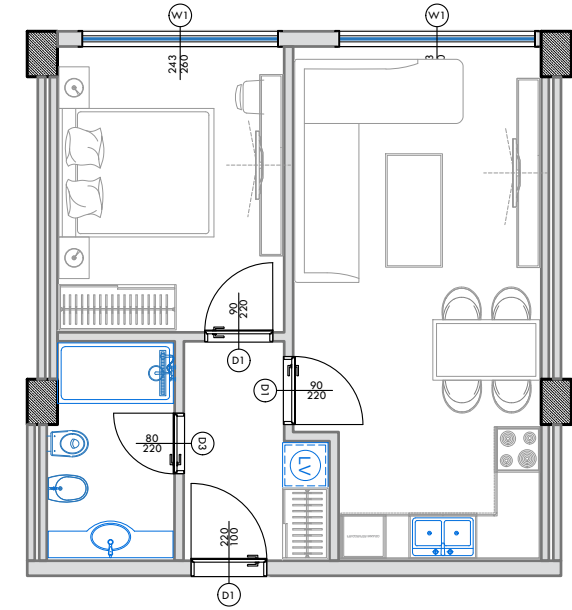
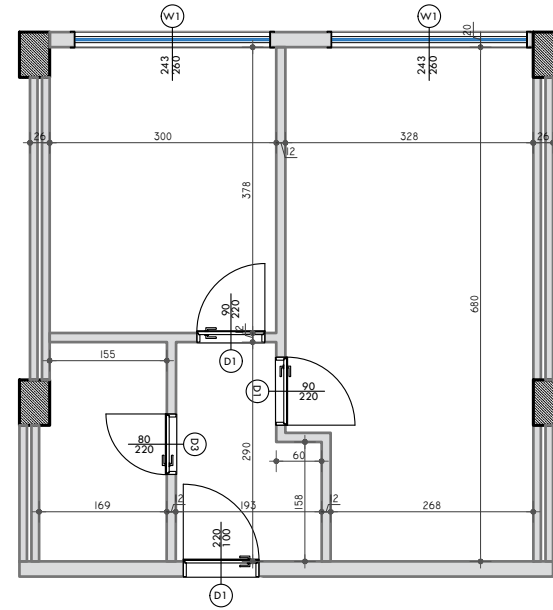

**PLANIMETRIA E APARTAMENTIT - PERMASIM**

**SHKALLA 1:100**

**PLANIMETRIA E APARTAMENTIT - MOBILIM**

**SHKALLA 1:100**

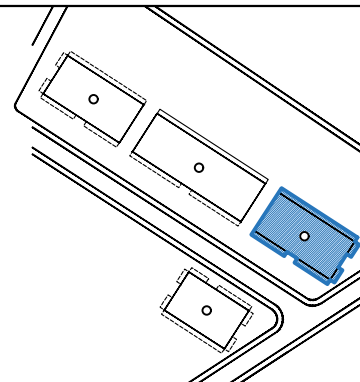

**POZICIONI I APARTAMENTIT NE PLANIMETRINE E KATIT**

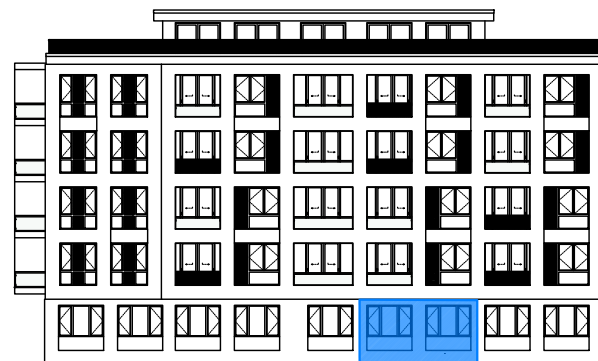

**POZICIONI I APARTAMENTIT NE ALTIMETRI - FASADA VERIORE**



**PAMJE 3 DIMENSIONALE E APARTAMENTIT**

**NR.1**



**PAMJE 3 DIMENSIONALE E APARTAMENTIT**

**NR.2**

**“4 GODINA BANIMI DHE SHËRBIMI 5 KATE DHE 1 KAT PARKIM NËNTOKË”**  
**Adresa: Pavarsia e Kosovës, Golem - Bashkia Kavajë**

**INVESTITOR DHE SUBJEKT NDERTUES:**

**"LOREDIS" Sh.p.k**  
**NIPT: M32202503U**  
**Kavajë / Albania**  
**Tel: +355694080880**

**PROJEKTUES:**

**VAEKU STUDIO**  
**NIPT: M11319016N**  
**Adresa: "Kompleksi Magnet",**  
**Njësia Lyra 2018\_1**  
**Njësia Administrative Nr.7**  
**Tiranë/Albania**  
**E-mail: u.hoxha@vaeku.studio**  
**Tel: +355674088492**



**APARTAMENTI NR:**

**P7**

**Objekti Nr :**

**3**

**Kati :**

**0**

**Orientimi :**

**VERI**

**Siperfaqe Apartamenti :**

**55.2 m<sup>2</sup>**

**Ambjente te perbashketa:**

**5.9 m<sup>2</sup>**

**Siperfaqe totale:**

**61.1 m<sup>2</sup>**

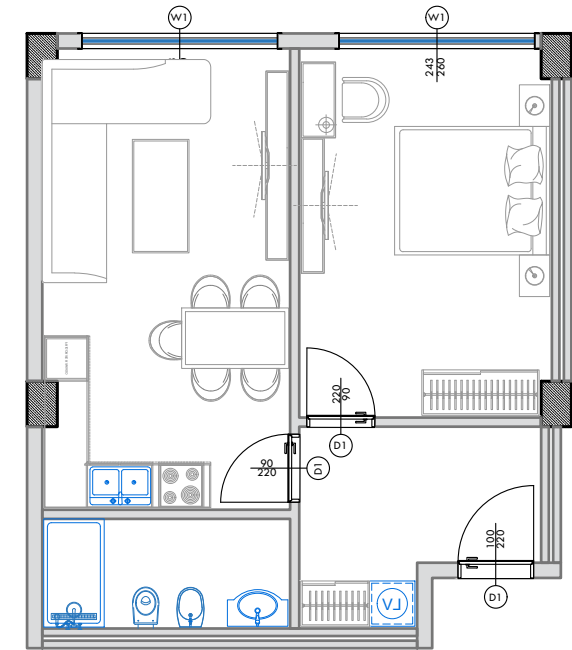
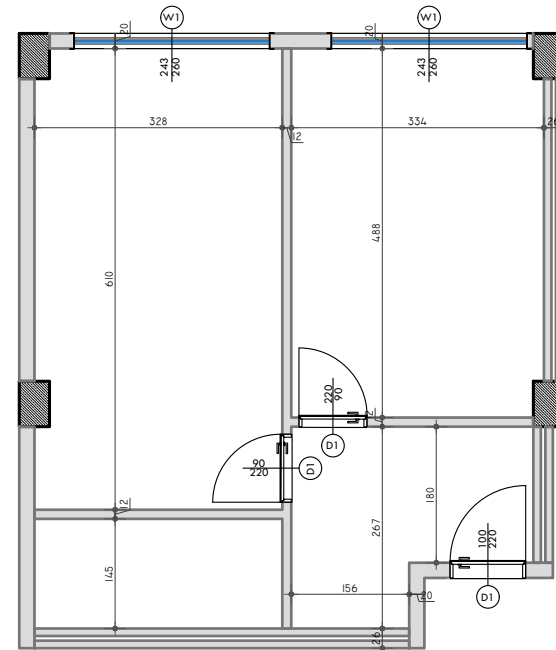

**PLANIMETRIA E APARTAMENTIT - PERMASIM**

**SHKALLA 1:100**

**PLANIMETRIA E APARTAMENTIT - MOBILIM**

**SHKALLA 1:100**

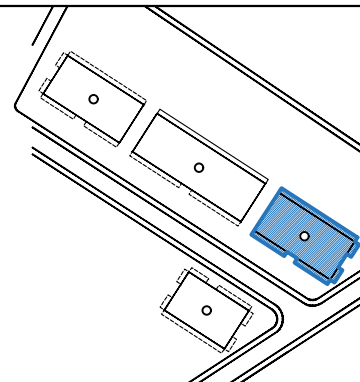

**POZICIONI I APARTAMENTIT NE PLANIMETRINE E KATIT**



**PAMJE 3 DIMENSIONALE E APARTAMENTIT**

**NR.1**



**PAMJE 3 DIMENSIONALE E APARTAMENTIT**

**NR.2**



**POZICIONI I APARTAMENTIT NE ALTIMETRI - FASADA VERIORE**





**“4 GODINA BANIMI DHE SHËRBIMI 5 KATE DHE 1 KAT PARKIM NËNTOKË”**  
**Adresa: Pavarsia e Kosovës, Golem - Bashkia Kavajë**

**INVESTITOR DHE SUBJEKT NDERTUES:**

**"LOREDIS" Sh.p.k**  
**NIPT: M32202503U**  
**Kavajë / Albania**  
**Tel: +355694080880**

**PROJEKTUES:**

**VAEKU STUDIO**  
**NIPT: M11319016N**  
**Adresa: "Kompleksi Magnet",**  
**Njësia Lyra 2018\_1**  
**Njësia Administrative Nr.7**  
**Tiranë/Albania**  
**E-mail: u.hoxha@vaeku.studio**  
**Tel: +355674088492**



**APARTAMENTI NR:**

**P9**

**Objekti Nr :**

**3**

**Kati :**

**0**

**Orientimi :**

**JUG**

**Siperfaqe Apartamenti :**

**49.0 m<sup>2</sup>**

**Ambjente te perbashketa:**

**5.3 m<sup>2</sup>**

**Siperfaqe totale:**

**54.3 m<sup>2</sup>**

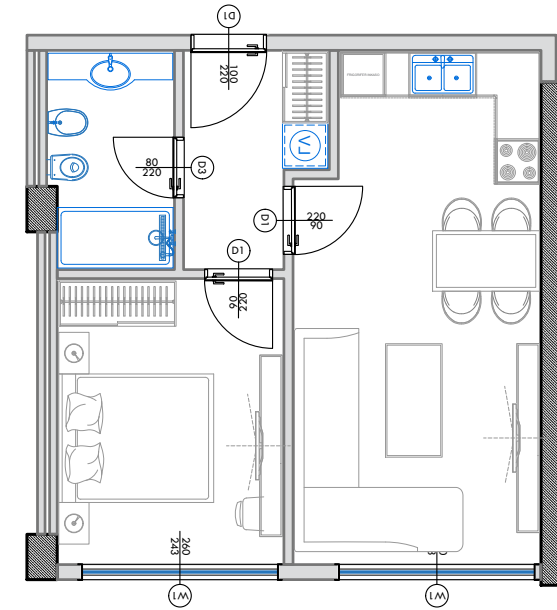
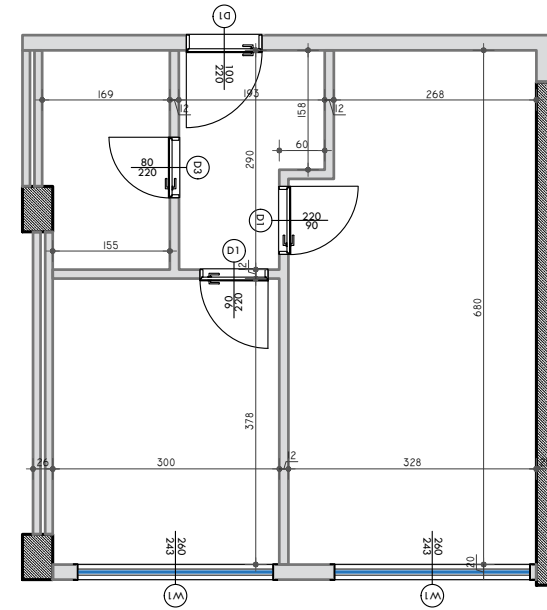

**PLANIMETRIA E APARTAMENTIT - PERMASIM**

**SHKALLA 1:100**

**PLANIMETRIA E APARTAMENTIT - MOBILIM**

**SHKALLA 1:100**

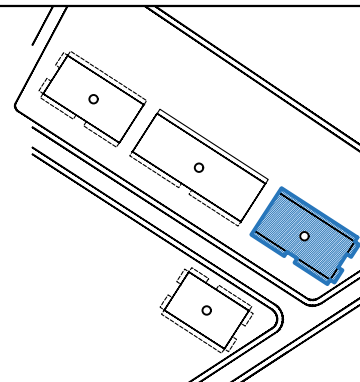

**POZICIONI I APARTAMENTIT NE PLANIMETRINE E KATIT**



**POZICIONI I APARTAMENTIT NE ALTIMETRI - FASADA JUGORE**

**PAMJE 3 DIMENSIONALE E APARTAMENTIT**

**NR.1**

**PAMJE 3 DIMENSIONALE E APARTAMENTIT**

**NR.2**

**“4 GODINA BANIMI DHE SHËRBIMI 5 KATE DHE 1 KAT PARKIM NËNTOKË”**  
**Adresa: Pavarsia e Kosovës, Golem - Bashkia Kavajë**

**INVESTITOR DHE SUBJEKT NDERTUES:**

**"LOREDIS" Sh.p.k**  
**NIPT: M32202503U**  
**Kavajë / Albania**  
**Tel: +355694080880**

**PROJEKTUES:**

**VAEKU STUDIO**  
**NIPT: M11319016N**  
**Adresa: "Kompleksi Magnet",**  
**Njësia Lyra 2018\_1**  
**Njësia Administrative Nr.7**  
**Tiranë/Albania**  
**E-mail: u.hoxha@vaeku.studio**  
**Tel: +355674088492**



**APARTAMENTI NR:**

**01**

**Objekti Nr :**

**3**

**Kati :**

**1**

**Orientimi :**

**JUG**

**Siperfaqe Apartamenti :**

**61.0 m<sup>2</sup>**

**Ambjente te perbashketa:**

**6.5 m<sup>2</sup>**

**Siperfaqe totale:**

**67.5 m<sup>2</sup>**

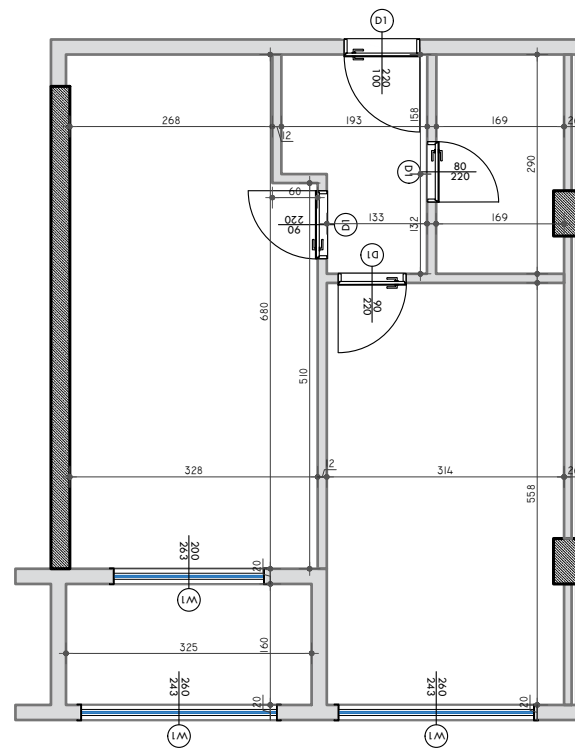

**PLANIMETRIA E APARTAMENTIT - PERMASIM**

**SHKALLA 1:100**

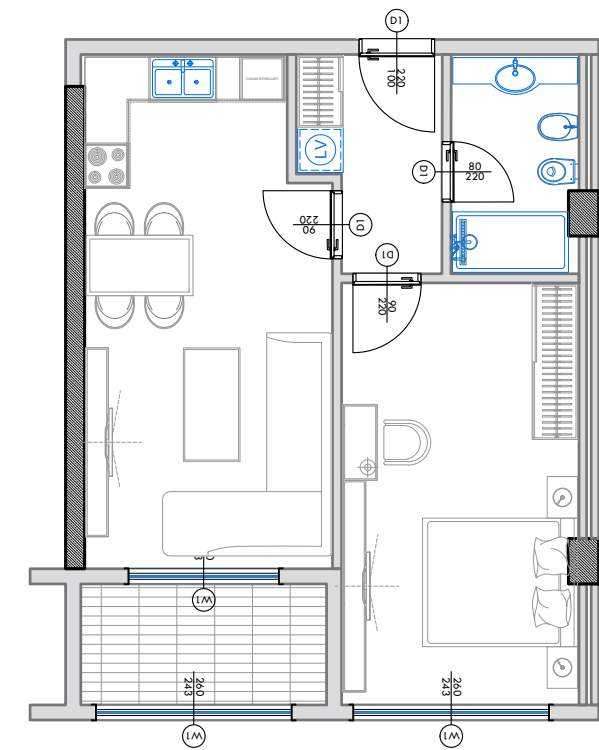

**PLANIMETRIA E APARTAMENTIT - MOBILIM**

**SHKALLA 1:100**

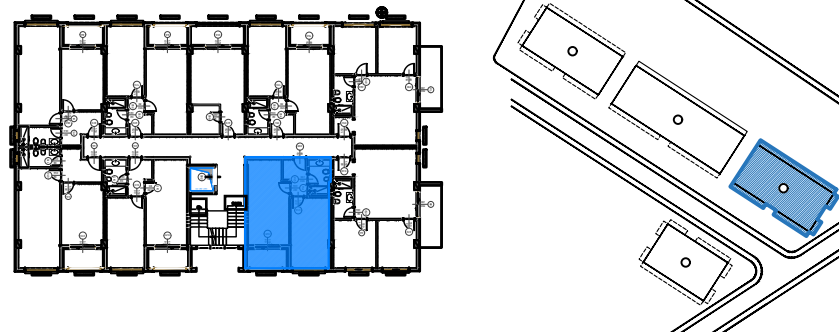

**POZICIONI I APARTAMENTIT NE PLANIMETRINE E KATIT**



**POZICIONI I APARTAMENTIT NE ALTIMETRI -JUGORE**



**PAMJE 3 DIMENSIONALE E APARTAMENTIT**

**NR.1**



**PAMJE 3 DIMENSIONALE E APARTAMENTIT**

**NR.2**

**“4 GODINA BANIMI DHE SHËRBIMI 5 KATE DHE 1 KAT PARKIM NËNTOKË”**  
**Adresa: Pavarsia e Kosovës, Golem - Bashkia Kavajë**

**INVESTITOR DHE SUBJEKT NDERTUES:**

**"LOREDIS" Sh.p.k**  
**NIPT: M32202503U**  
**Kavajë / Albania**  
**Tel: +355694080880**

**PROJEKTUES:**

**VAEKU STUDIO**  
**NIPT: M11319016N**  
**Adresa: "Kompleksi Magnet",**  
**Njësia Lyra 2018\_1**  
**Njësia Administrative Nr.7**  
**Tiranë/Albania**  
**E-mail: u.hoxha@vaeku.studio**  
**Tel: +355674088492**



**APARTAMENTI NR:**

**02**

**Objekti Nr :**

**3**

**Kati :**

**1**

**Orientimi :**

**JUG**

**Siperfaqe Apartamenti :**

**67.4 m<sup>2</sup>**

**Ambjente te perbashketa:**

**7.2 m<sup>2</sup>**

**Siperfaqe totale:**

**74.6 m<sup>2</sup>**

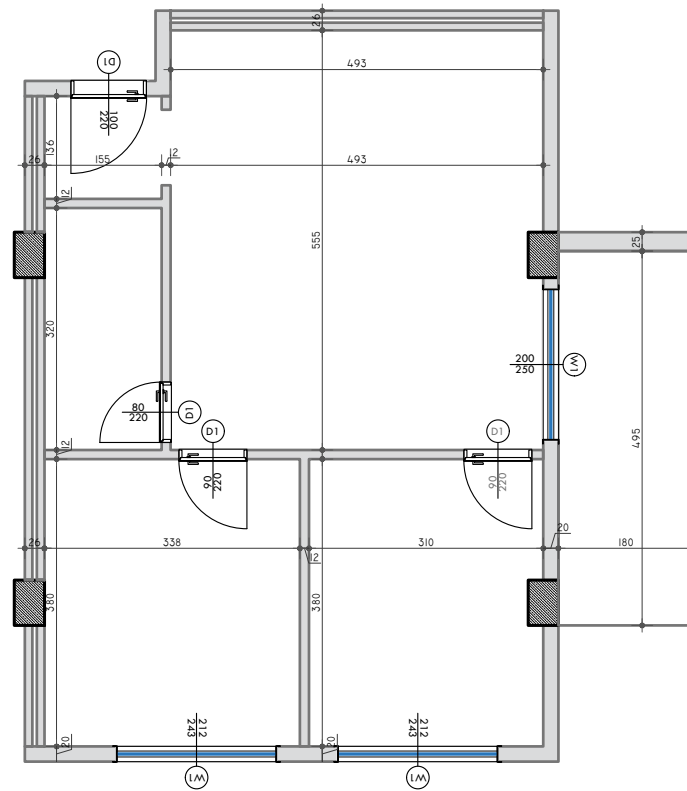

**PLANIMETRIA E APARTAMENTIT - PERMASIM**

**SHKALLA 1:100**

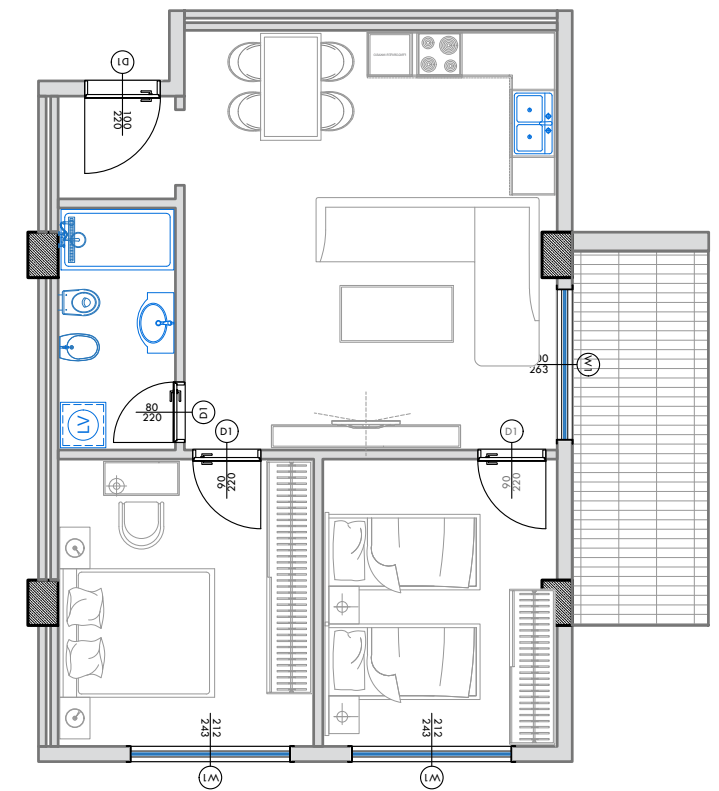

**PLANIMETRIA E APARTAMENTIT - MOBILIM**

**SHKALLA 1:100**

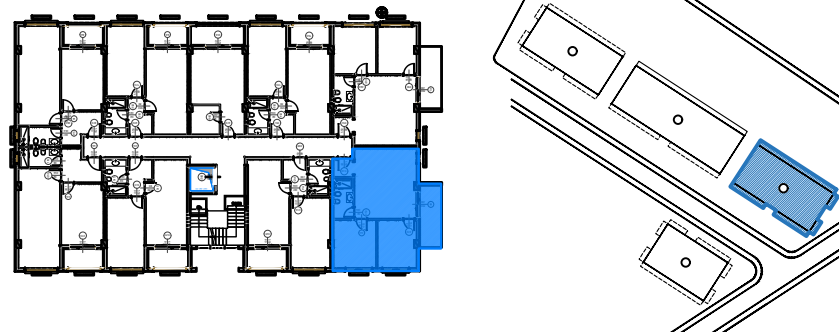

**POZICIONI I APARTAMENTIT NE PLANIMETRINE E KATIT**



**POZICIONI I APARTAMENTIT NE ALTIMETRI - FASADA JUGORE**



**PAMJE 3 DIMENSIONALE E APARTAMENTIT**

**NR.1**



**PAMJE 3 DIMENSIONALE E APARTAMENTIT**

**NR.2**



**“4 GODINA BANIMI DHE SHËRBIMI 5 KATE DHE 1 KAT PARKIM NËNTOKË”**  
**Adresa: Pavarsia e Kosovës, Golem - Bashkia Kavajë**

**INVESTITOR DHE SUBJEKT NDERTUES:**

**"LOREDIS" Sh.p.k**  
**NIPT: M32202503U**  
**Kavajë / Albania**  
**Tel: +355694080880**

**PROJEKTUES:**

**VAEKU STUDIO**  
**NIPT: M11319016N**  
**Adresa: "Kompleksi Magnet",**  
**Njësia Lyra 2018\_1**  
**Njësia Administrative Nr.7**  
**Tiranë/Albania**  
**E-mail: u.hoxha@vaeku.studio**  
**Tel: +355674088492**



**APARTAMENTI NR:**

**04**

**Objekti Nr :**

**3**

**Kati :**

**1**

**Orientimi :**

**VERI**

**Siperfaqe Apartamenti :**

**61.0 m<sup>2</sup>**

**Ambjente te perbashketa:**

**6.5 m<sup>2</sup>**

**Siperfaqe totale:**

**67.5 m<sup>2</sup>**

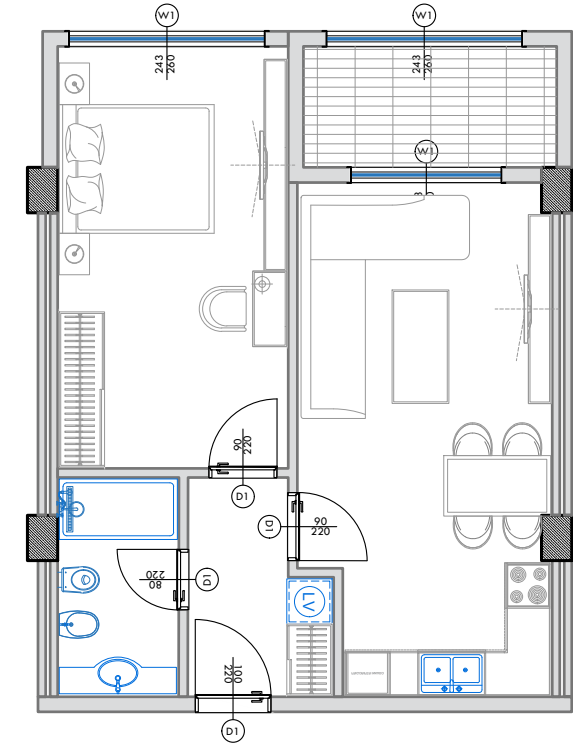
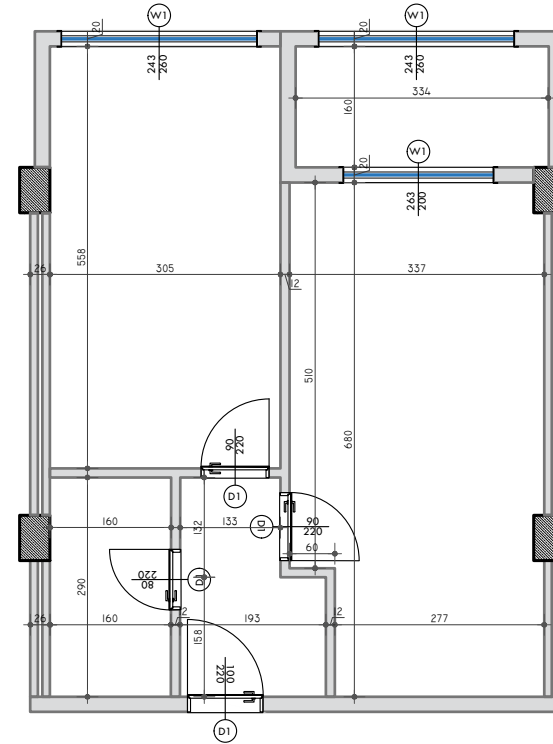

**PLANIMETRIA E APARTAMENTIT - PERMASIM**

**SHKALLA 1:100**

**PLANIMETRIA E APARTAMENTIT - MOBILIM**

**SHKALLA 1:100**

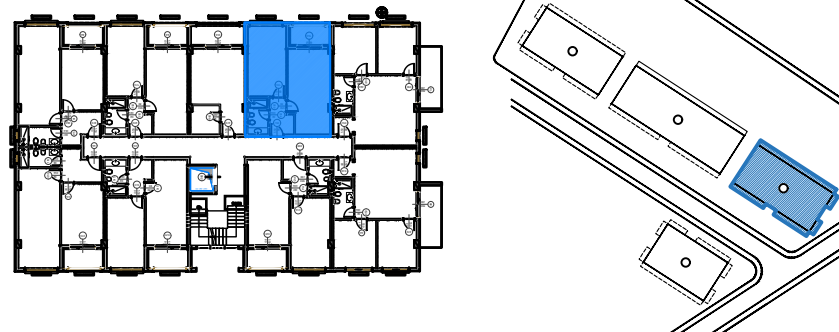

**POZICIONI I APARTAMENTIT NE PLANIMETRINE E KATIT**



**POZICIONI I APARTAMENTIT NE ALTIMETRI - FASADA VERIORE**



**PAMJE 3 DIMENSIONALE E APARTAMENTIT**

**NR.1**



**PAMJE 3 DIMENSIONALE E APARTAMENTIT**

**NR.2**

**“4 GODINA BANIMI DHE SHËRBIMI 5 KATE DHE 1 KAT PARKIM NËNTOKË”**  
**Adresa: Pavarsia e Kosovës, Golem - Bashkia Kavajë**

**INVESTITOR DHE SUBJEKT NDERTUES:**

**"LOREDIS" Sh.p.k**  
**NIPT: M32202503U**  
**Kavajë / Albania**  
**Tel: +355694080880**

**PROJEKTUES:**

**VAEKU STUDIO**  
**NIPT: M11319016N**  
**Adresa: "Kompleksi Magnet",**  
**Njësia Lyra 2018\_1**  
**Njësia Administrative Nr.7**  
**Tiranë/Albania**  
**E-mail: u.hoxha@vaeku.studio**  
**Tel: +355674088492**



# SHITUR B

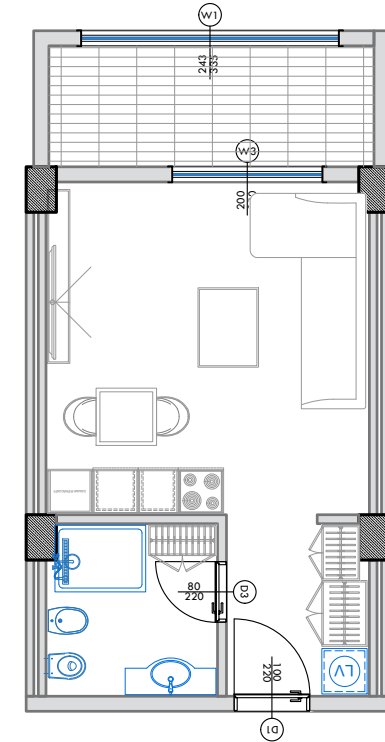
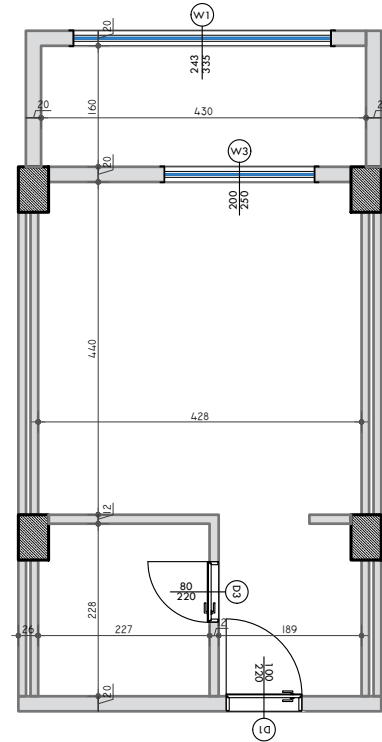

APARTAMENTI NR:	<b>05</b>
Objekti Nr :	3
Kati :	1
Orientimi :	VERI
Siperfaqe Apartamenti :	40.5 m <sup>2</sup>
Ambjente te perbashketa:	4.4 m <sup>2</sup>
Siperfaqe totale:	44.9 m <sup>2</sup>



**PLANIMETRIA E APARTAMENTIT - PERMASIM**

**SHKALLA 1:100**

**PLANIMETRIA E APARTAMENTIT - MOBILIM**

**SHKALLA 1:100**

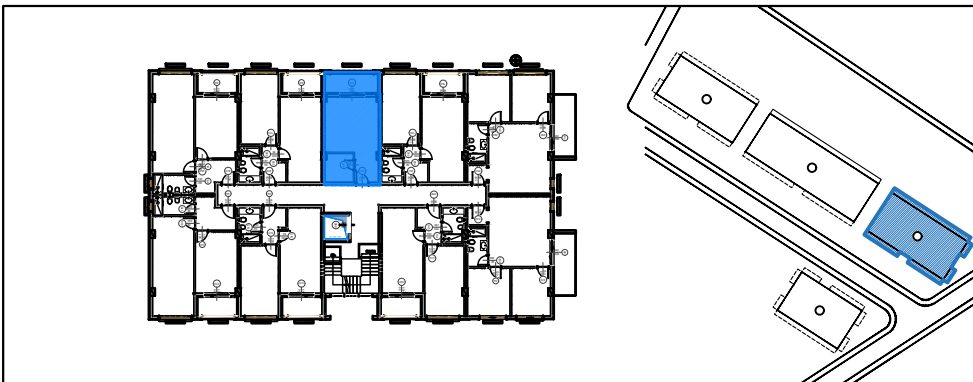

**POZICIONI I APARTAMENTIT NE PLANIMETRINE E KATIT**

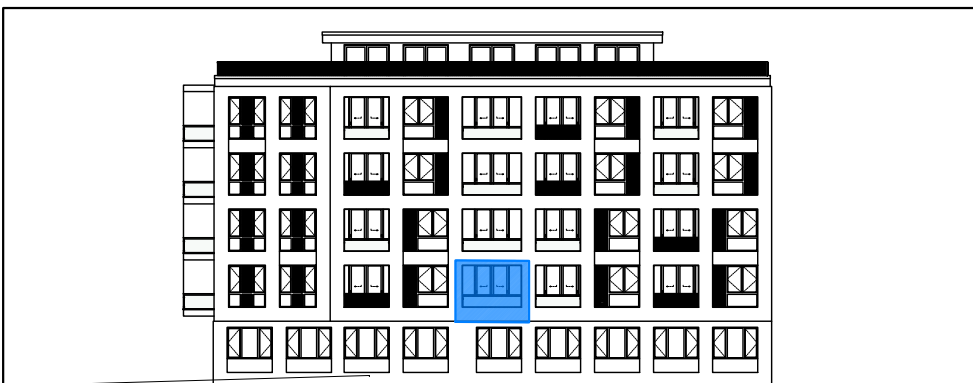

**POZICIONI I APARTAMENTIT NE ALTIMETRI - FASADA VERIORE**

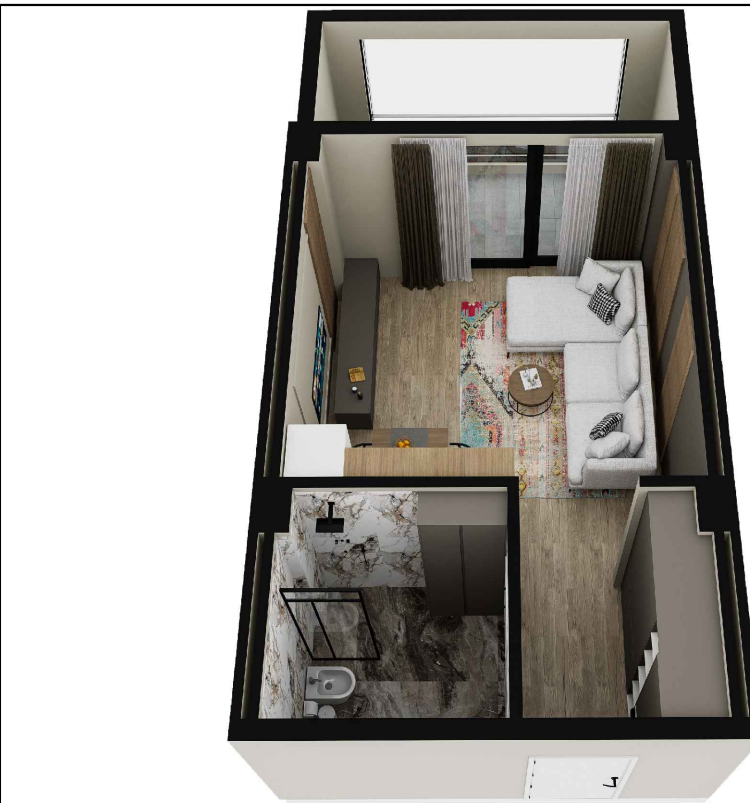

**PAMJE 3 DIMENSIONALE E APARTAMENTIT**

**NR.1**



**PAMJE 3 DIMENSIONALE E APARTAMENTIT**

**NR.2**

**“4 GODINA BANIMI DHE SHËRBIMI 5 KATE DHE 1 KAT PARKIM NËNTOKË”**  
**Adresa: Pavarsia e Kosovës, Golem - Bashkia Kavajë**

**INVESTITOR DHE SUBJEKT NDERTUES:**

**"LOREDIS" Sh.p.k**  
**NIPT: M32202503U**  
**Kavajë / Albania**  
**Tel: +355694080880**

**PROJEKTUES:**

**VAEKU STUDIO**  
**NIPT: M11319016N**  
**Adresa: "Kompleksi Magnet",**  
**Njësia Lyra 2018\_1**  
**Njësia Administrative Nr.7**  
**Tiranë/Albania**  
**E-mail: u.hoxha@vaeku.studio**  
**Tel: +355674088492**



**APARTAMENTI NR:**

**06**

**Objekti Nr :**

**3**

**Kati :**

**1**

**Orientimi :**

**VERI**

**Siperfaqe Apartamenti :**

**61.0 m<sup>2</sup>**

**Ambjente te perbashketa:**

**6.5 m<sup>2</sup>**

**Siperfaqe totale:**

**67.5 m<sup>2</sup>**

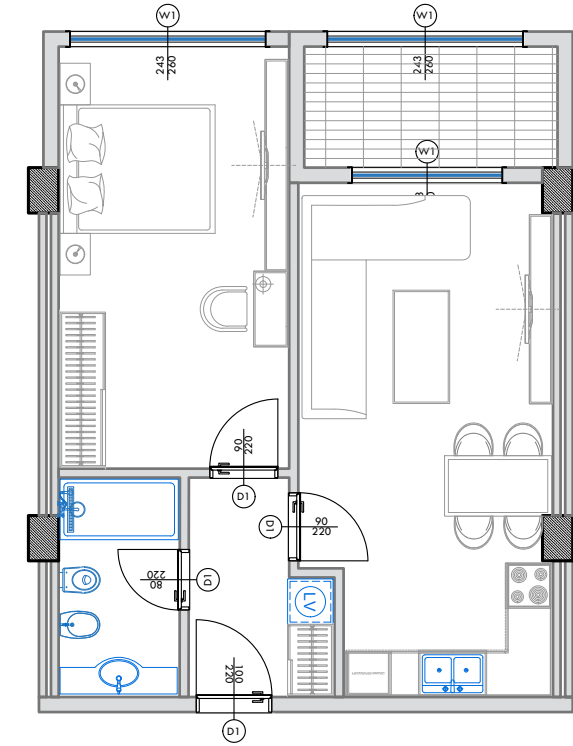
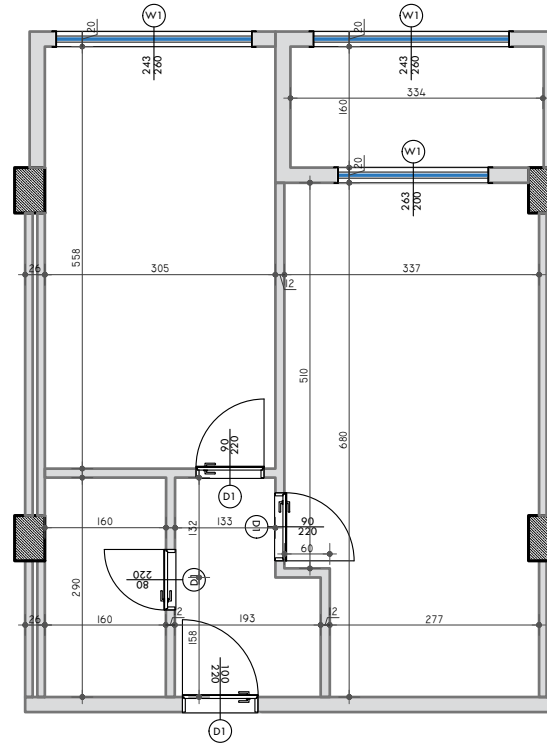

**PLANIMETRIA E APARTAMENTIT - PERMASIM**

**SHKALLA 1:100**

**PLANIMETRIA E APARTAMENTIT - MOBILIM**

**SHKALLA 1:100**

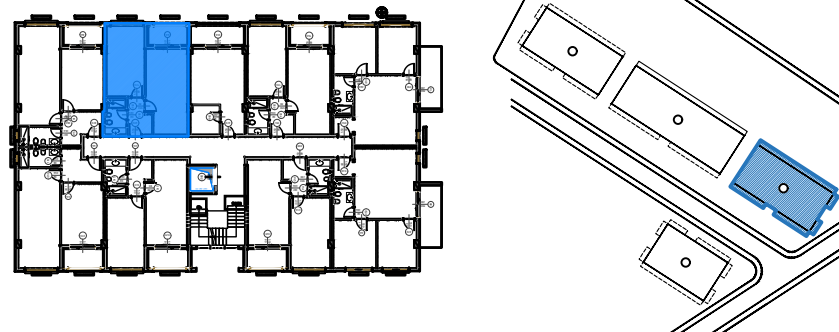

**POZICIONI I APARTAMENTIT NE PLANIMETRINE E KATIT**



**POZICIONI I APARTAMENTIT NE ALTIMETRI - FASADA VERIORE**



**PAMJE 3 DIMENSIONALE E APARTAMENTIT**

**NR.1**



**PAMJE 3 DIMENSIONALE E APARTAMENTIT**

**NR.2**





**“4 GODINA BANIMI DHE SHËRBIMI 5 KATE DHE 1 KAT PARKIM NËNTOKË”**  
**Adresa: Pavarsia e Kosovës, Golem - Bashkia Kavajë**

**INVESTITOR DHE SUBJEKT NDERTUES:**

**"LOREDIS" Sh.p.k**  
**NIPT: M32202503U**  
**Kavajë / Albania**  
**Tel: +355694080880**

**PROJEKTUES:**

**VAEKU STUDIO**  
**NIPT: M11319016N**  
**Adresa: "Kompleksi Magnet",**  
**Njësia Lyra 2018\_1**  
**Njësia Administrative Nr.7**  
**Tiranë/Albania**  
**E-mail: u.hoxha@vaeku.studio**  
**Tel: +355674088492**



**APARTAMENTI NR:**

**08**

**Objekti Nr :**

**3**

**Kati :**

**1**

**Orientimi :**

**JUG**

**Siperfaqe Apartamenti :**

**67.4 m<sup>2</sup>**

**Ambjente te perbashketa:**

**7.2 m<sup>2</sup>**

**Siperfaqe totale:**

**74.6 m<sup>2</sup>**

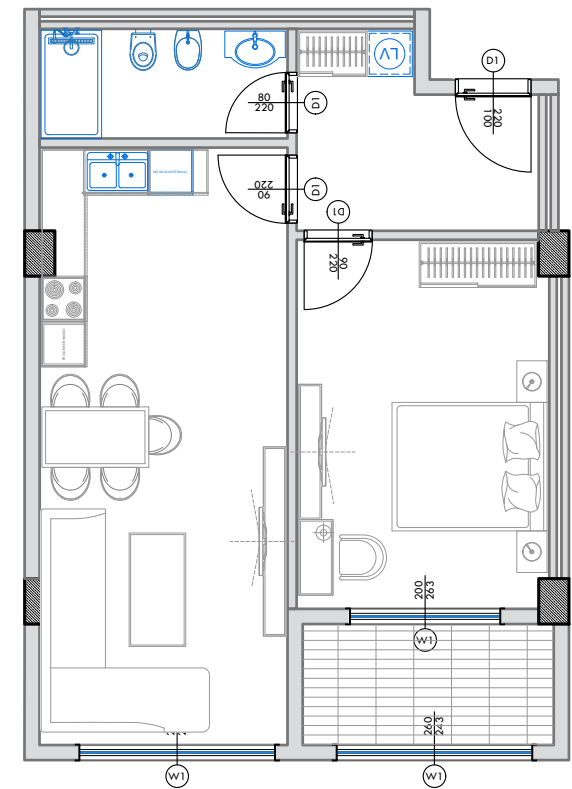
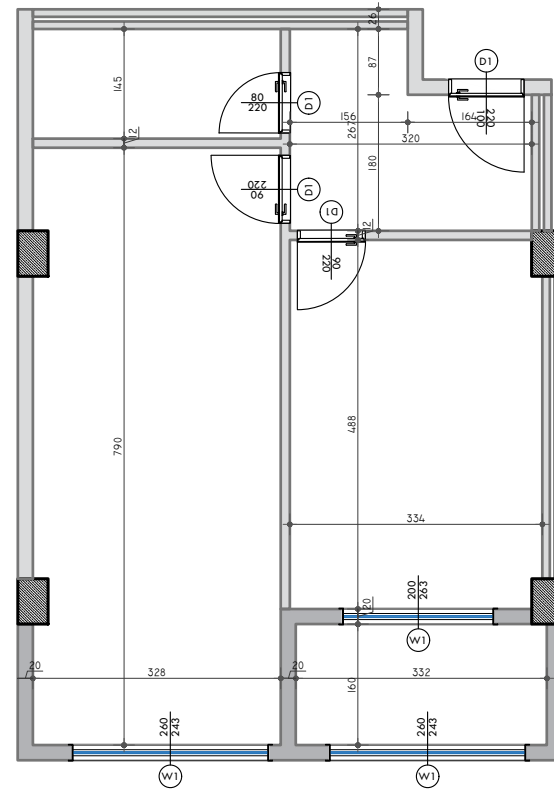

**PLANIMETRIA E APARTAMENTIT - PERMASIM**

**SHKALLA 1:100**

**PLANIMETRIA E APARTAMENTIT - MOBILIM**

**SHKALLA 1:100**

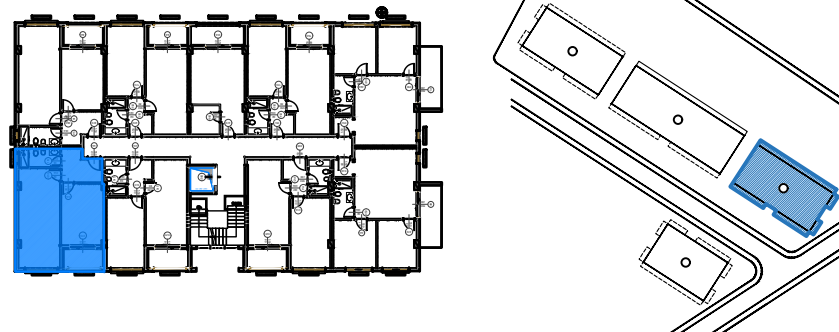

**POZICIONI I APARTAMENTIT NE PLANIMETRINE E KATIT**



**PAMJE 3 DIMENSIONALE E APARTAMENTIT**

**NR.1**



**PAMJE 3 DIMENSIONALE E APARTAMENTIT**

**NR.2**



**POZICIONI I APARTAMENTIT NE ALTIMETRI - FASADA JUGORE**

**“4 GODINA BANIMI DHE SHËRBIMI 5 KATE DHE 1 KAT PARKIM NËNTOKË”**  
**Adresa: Pavarsia e Kosovës, Golem - Bashkia Kavajë**

**INVESTITOR DHE SUBJEKT NDERTUES:**

**"LOREDIS" Sh.p.k**  
**NIPT: M32202503U**  
**Kavajë / Albania**  
**Tel: +355694080880**

**PROJEKTUES:**

**VAEKU STUDIO**  
**NIPT: M11319016N**  
**Adresa: "Kompleksi Magnet",**  
**Njësia Lyra 2018\_1**  
**Njësia Administrative Nr.7**  
**Tiranë/Albania**  
**E-mail: u.hoxha@vaeku.studio**  
**Tel: +355674088492**



**APARTAMENTI NR:**

**09**

**Objekti Nr :**

**3**

**Kati :**

**1**

**Orientimi :**

**JUG**

**Siperfaqe Apartamenti :**

**61.0 m<sup>2</sup>**

**Ambjente te perbashketa:**

**6.5 m<sup>2</sup>**

**Siperfaqe totale:**

**67.5 m<sup>2</sup>**

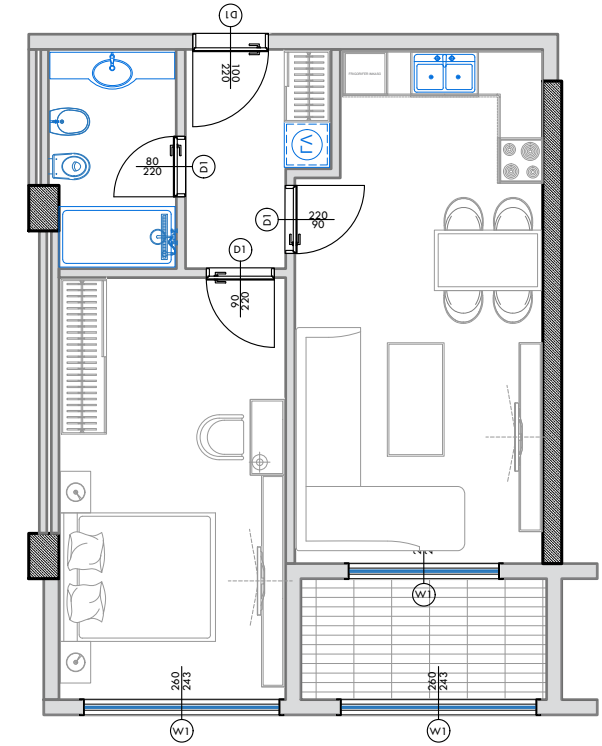
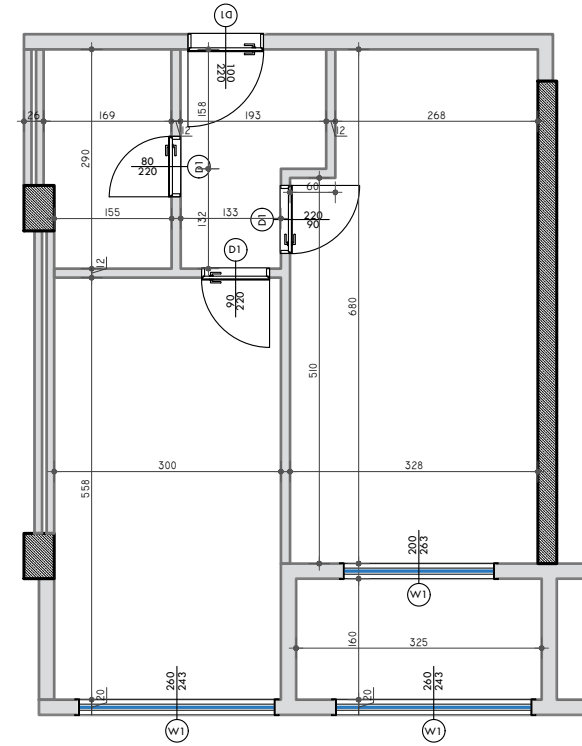

**PLANIMETRIA E APARTAMENTIT - PERMASIM**

**SHKALLA 1:100**

**PLANIMETRIA E APARTAMENTIT - MOBILIM**

**SHKALLA 1:100**

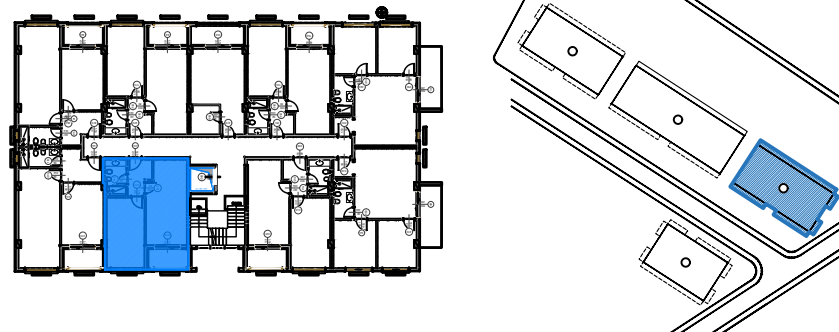

**POZICIONI I APARTAMENTIT NE PLANIMETRINE E KATIT**



**POZICIONI I APARTAMENTIT NE ALTIMETRI - FASADA JUGORE**



**PAMJE 3 DIMENSIONALE E APARTAMENTIT**

**NR.1**



**PAMJE 3 DIMENSIONALE E APARTAMENTIT**

**NR.2**

**“4 GODINA BANIMI DHE SHËRBIMI 5 KATE DHE 1 KAT PARKIM NËNTOKË”**  
**Adresa: Pavarsia e Kosovës, Golem - Bashkia Kavajë**

**INVESTITOR DHE SUBJEKT NDERTUES:**

**"LOREDIS" Sh.p.k**  
**NIPT: M32202503U**  
**Kavajë / Albania**  
**Tel: +355694080880**

**PROJEKTUES:**

**VAEKU STUDIO**  
**NIPT: M11319016N**  
**Adresa: "Kompleksi Magnet",**  
**Njësia Lyra 2018\_1**  
**Njësia Administrative Nr.7**  
**Tiranë/Albania**  
**E-mail: u.hoxha@vaeku.studio**  
**Tel: +355674088492**



**APARTAMENTI NR:**

**10**

**Objekti Nr :**

**3**

**Kati :**

**2**

**Orientimi :**

**JUG**

**Siperfaqe Apartamenti :**

**61.0 m<sup>2</sup>**

**Ambjente te perbashketa:**

**6.5 m<sup>2</sup>**

**Siperfaqe totale:**

**67.5 m<sup>2</sup>**

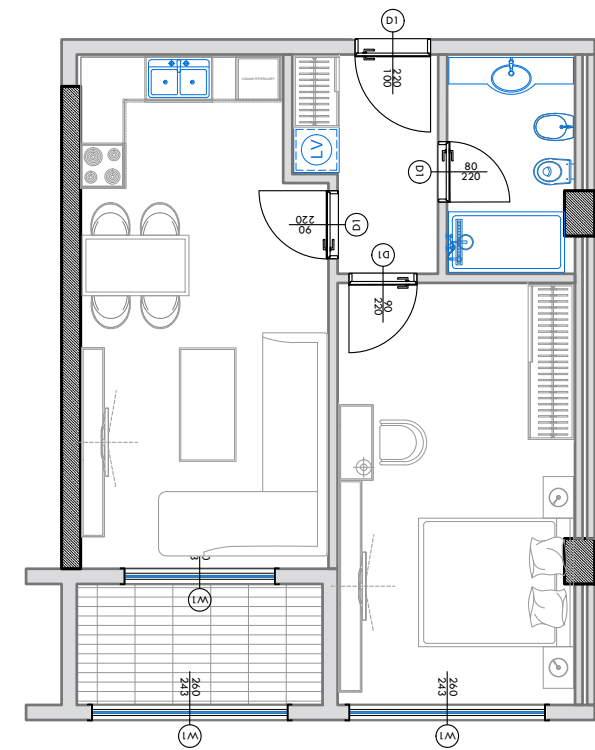
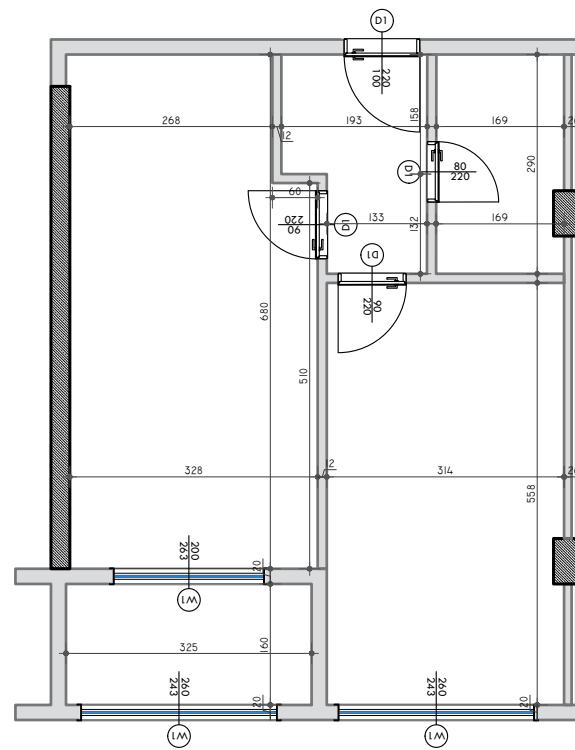

**PLANIMETRIA E APARTAMENTIT - PERMASIM**

**SHKALLA 1:100**

**PLANIMETRIA E APARTAMENTIT - MOBILIM**

**SHKALLA 1:100**

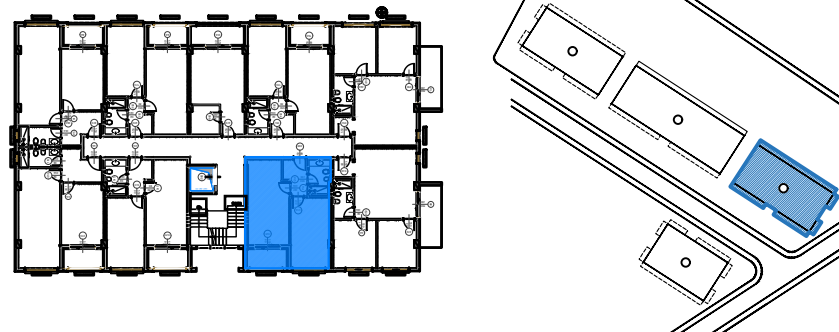

**POZICIONI I APARTAMENTIT NE PLANIMETRINE E KATIT**



**POZICIONI I APARTAMENTIT NE ALTIMETRI -JUGORE**



**PAMJE 3 DIMENSIONALE E APARTAMENTIT**

**NR.1**



**PAMJE 3 DIMENSIONALE E APARTAMENTIT**

**NR.2**

**“4 GODINA BANIMI DHE SHËRBIMI 5 KATE DHE 1 KAT PARKIM NËNTOKË”**  
**Adresa: Pavarsia e Kosovës, Golem - Bashkia Kavajë**

**INVESTITOR DHE SUBJEKT NDERTUES:**

**"LOREDIS" Sh.p.k**  
**NIPT: M32202503U**  
**Kavajë / Albania**  
**Tel: +355694080880**

**PROJEKTUES:**

**VAEKU STUDIO**  
**NIPT: M11319016N**  
**Adresa: "Kompleksi Magnet",**  
**Njësia Lyra 2018\_1**  
**Njësia Administrative Nr.7**  
**Tiranë/Albania**  
**E-mail: u.hoxha@vaeku.studio**  
**Tel: +355674088492**



**APARTAMENTI NR:**

**11**

**Objekti Nr :**

**3**

**Kati :**

**2**

**Orientimi :**

**JUG**

**Siperfaqe Apartamenti :**

**67.4 m<sup>2</sup>**

**Ambjente te perbashketa:**

**7.2 m<sup>2</sup>**

**Siperfaqe totale:**

**74.6 m<sup>2</sup>**



**SHITUR ENKI**

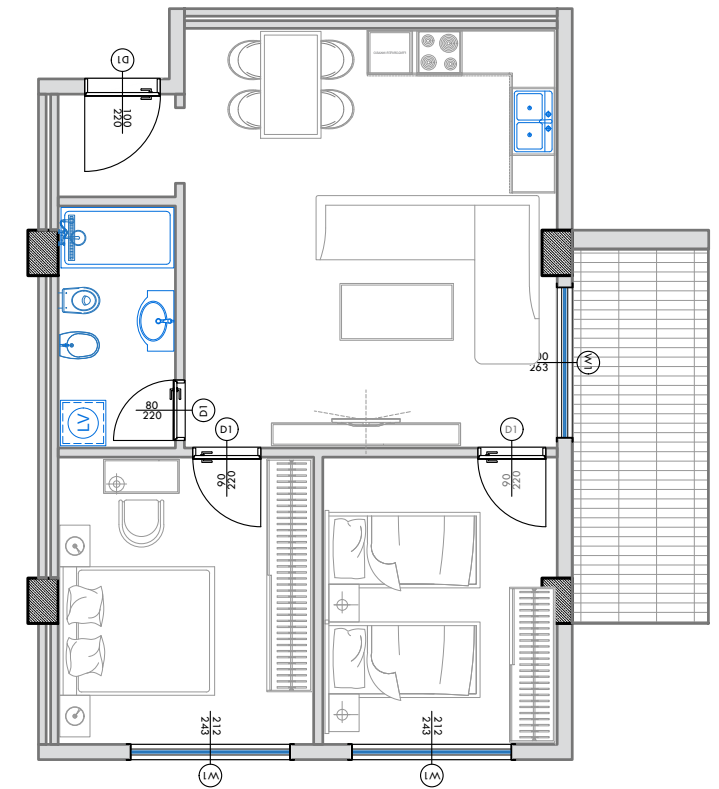
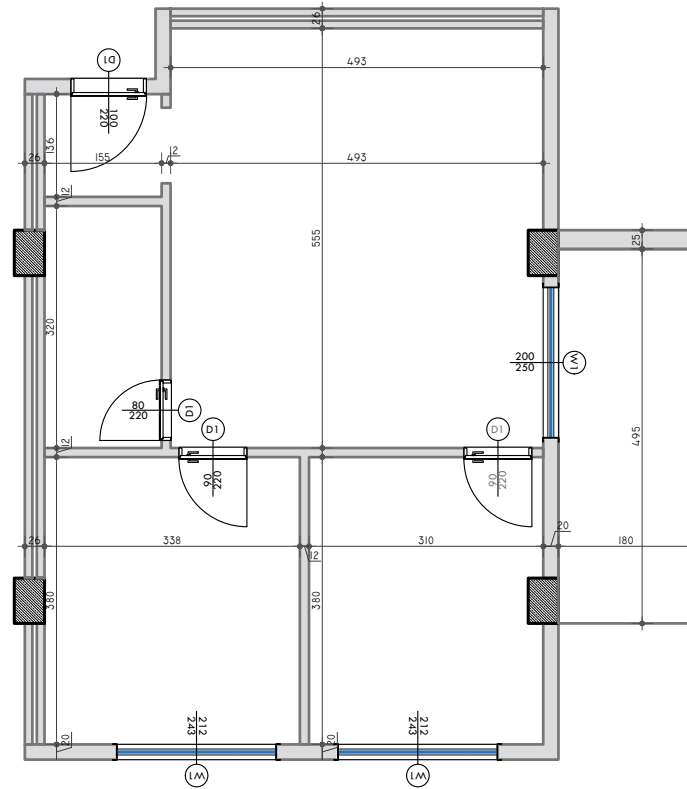

**PLANIMETRIA E APARTAMENTIT - PERMASIM**

**SHKALLA 1:100**

**PLANIMETRIA E APARTAMENTIT - MOBILIM**

**SHKALLA 1:100**

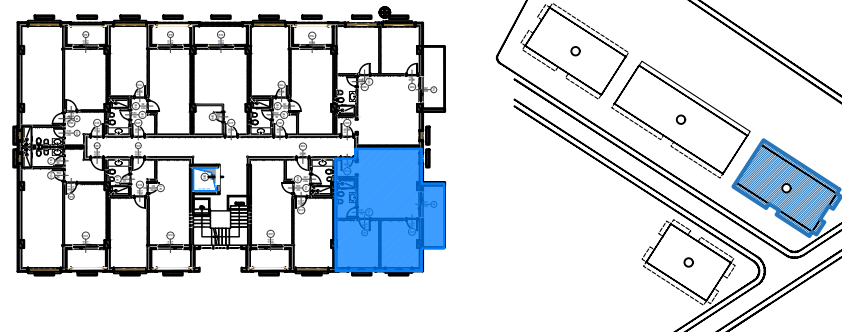

**POZICIONI I APARTAMENTIT NE PLANIMETRINE E KATIT**



**POZICIONI I APARTAMENTIT NE ALTIMETRI - FASADA JUGORE**



**PAMJE 3 DIMENSIONALE E APARTAMENTIT**

**NR.1**



**PAMJE 3 DIMENSIONALE E APARTAMENTIT**

**NR.2**



**“4 GODINA BANIMI DHE SHËRBIMI 5 KATE DHE 1 KAT PARKIM NËNTOKË”**  
**Adresa: Pavarsia e Kosovës, Golem - Bashkia Kavajë**

**INVESTITOR DHE SUBJEKT NDERTUES:**

**"LOREDIS" Sh.p.k**  
**NIPT: M32202503U**  
**Kavajë / Albania**  
**Tel: +355694080880**

**PROJEKTUES:**

**VAEKU STUDIO**  
**NIPT: M11319016N**  
**Adresa: "Kompleksi Magnet",**  
**Njësia Lyra 2018\_1**  
**Njësia Administrative Nr.7**  
**Tiranë/Albania**  
**E-mail: u.hoxha@vaeku.studio**  
**Tel: +355674088492**



**APARTAMENTI NR:**

**13**

**Objekti Nr :**

**3**

**Kati :**

**2**

**Orientimi :**

**VERI**

**Siperfaqe Apartamenti :**

**61.0 m<sup>2</sup>**

**Ambjente te perbashketa:**

**6.5 m<sup>2</sup>**

**Siperfaqe totale:**

**67.5 m<sup>2</sup>**

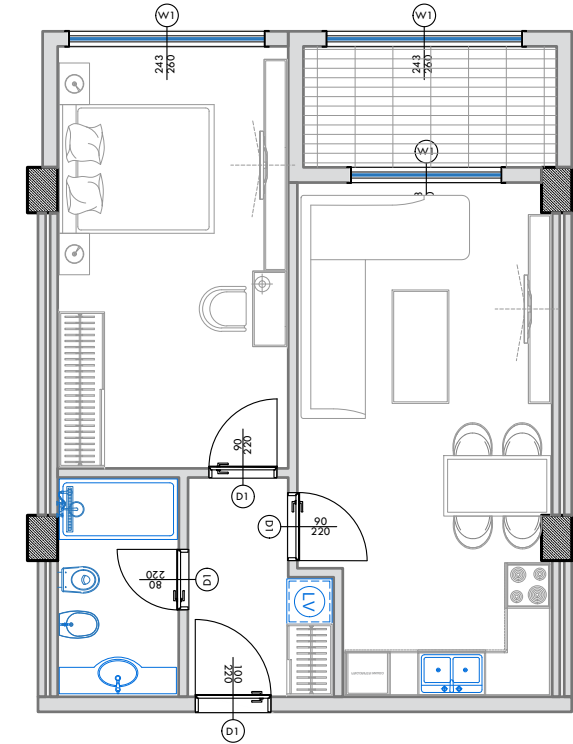
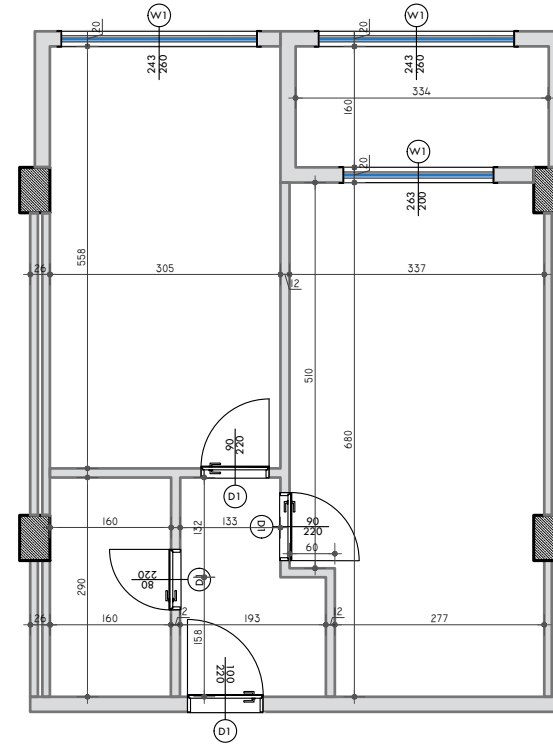

**PLANIMETRIA E APARTAMENTIT - PERMASIM**

**SHKALLA 1:100**

**PLANIMETRIA E APARTAMENTIT - MOBILIM**

**SHKALLA 1:100**

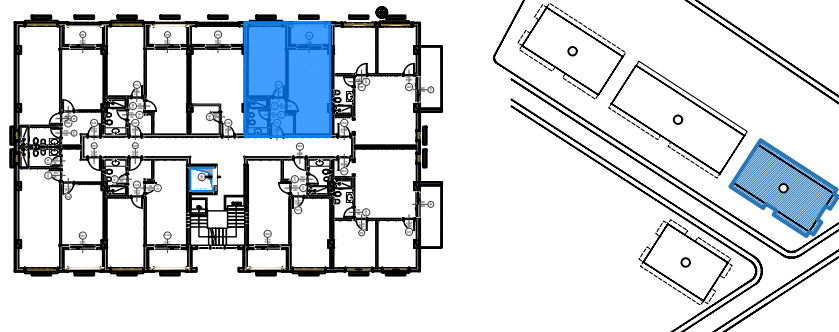

**POZICIONI I APARTAMENTIT NE PLANIMETRINE E KATIT**



**PAMJE 3 DIMENSIONALE E APARTAMENTIT**

**NR.1**



**PAMJE 3 DIMENSIONALE E APARTAMENTIT**

**NR.2**

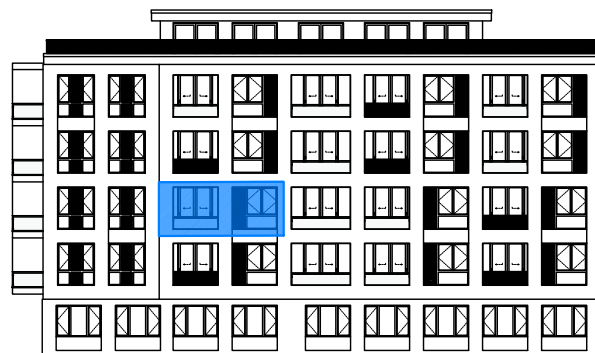

**POZICIONI I APARTAMENTIT NE ALTIMETRI - FASADA VERIORE**

**“4 GODINA BANIMI DHE SHËRBIMI 5 KATE DHE 1 KAT PARKIM NËNTOKË”**  
Adresa: Pavarsia e Kosovës, Golem - Bashkia Kavajë

**INVESTITOR DHE SUBJEKT NDERTUES:**

**"LOREDIS" Sh.p.k**  
NIPT: M32202503U  
Kavajë / Albania  
Tel: +355694080880

**PROJEKTUES:**

**VAEKU STUDIO**  
NIPT: M11319016N  
Adresa: "Kompleksi Magnet",  
Njësia Lyra 2018\_1  
Njësia Administrative Nr.7  
Tiranë/Albania  
E-mail: u.hoxha@vaeku.studio  
Tel: +355674088492



# SHITUR B

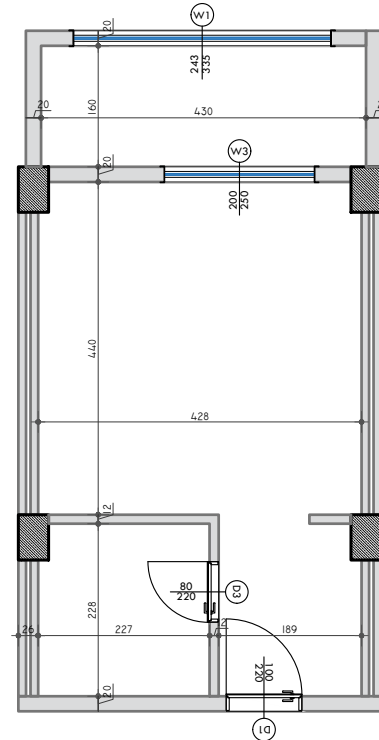

APARTAMENTI NR:	<b>14</b>
Objekti Nr :	3
Kati :	2
Orientimi :	VERI
Siperfaqe Apartamenti :	40.5 m <sup>2</sup>
Ambjente te perbashketa:	4.4 m <sup>2</sup>
Siperfaqe totale:	44.9 m <sup>2</sup>

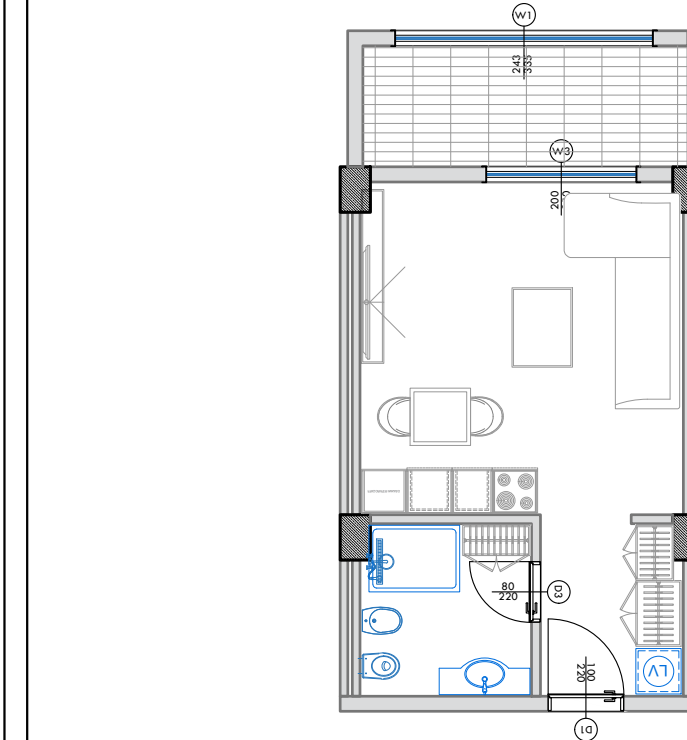

**PLANIMETRIA E APARTAMENTIT - PERMASIM**

**SHKALLA 1:100**

**PLANIMETRIA E APARTAMENTIT - MOBILIM**

**SHKALLA 1:100**

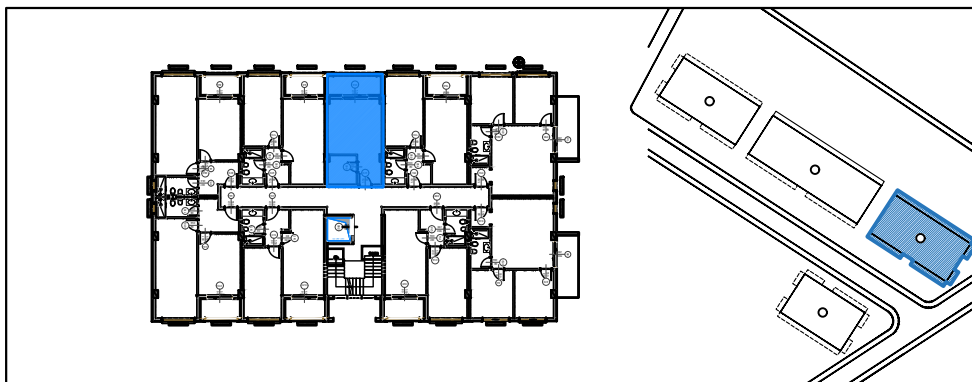

**POZICIONI I APARTAMENTIT NE PLANIMETRINE E KATIT**

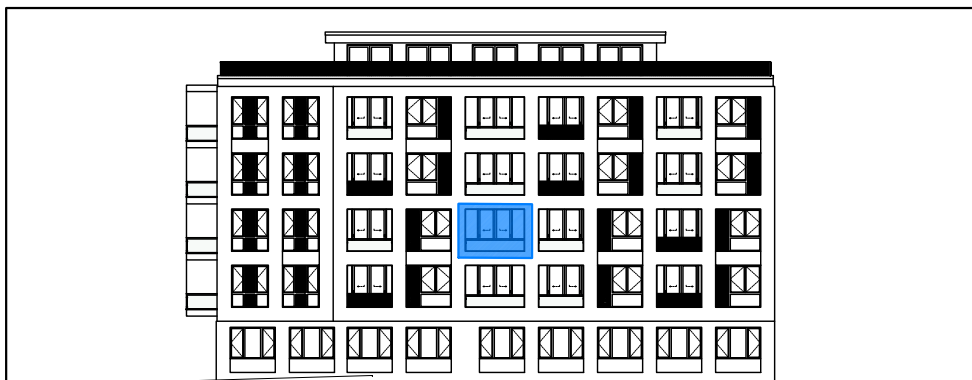

**POZICIONI I APARTAMENTIT NE ALTIMETRI - FASADA VERIORE**



**PAMJE 3 DIMENSIONALE E APARTAMENTIT**

**NR.1**



**PAMJE 3 DIMENSIONALE E APARTAMENTIT**

**NR.2**



**“4 GODINA BANIMI DHE SHËRBIMI 5 KATE DHE 1 KAT PARKIM NËNTOKË”**  
**Adresa: Pavarsia e Kosovës, Golem - Bashkia Kavajë**

**INVESTITOR DHE SUBJEKT NDERTUES:**

**"LOREDIS" Sh.p.k**  
**NIPT: M32202503U**  
**Kavajë / Albania**  
**Tel: +355694080880**

**PROJEKTUES:**

**VAEKU STUDIO**  
**NIPT: M11319016N**  
**Adresa: "Kompleksi Magnet",**  
**Njësia Lyra 2018\_1**  
**Njësia Administrative Nr.7**  
**Tiranë/Albania**  
**E-mail: u.hoxha@vaeku.studio**  
**Tel: +355674088492**



**APARTAMENTI NR:**

**15**

**Objekti Nr :**

**3**

**Kati :**

**2**

**Orientimi :**

**VERI**

**Siperfaqe Apartamenti :**

**61.0 m<sup>2</sup>**

**Ambjente te perbashketa:**

**6.5 m<sup>2</sup>**

**Siperfaqe totale:**

**67.5 m<sup>2</sup>**

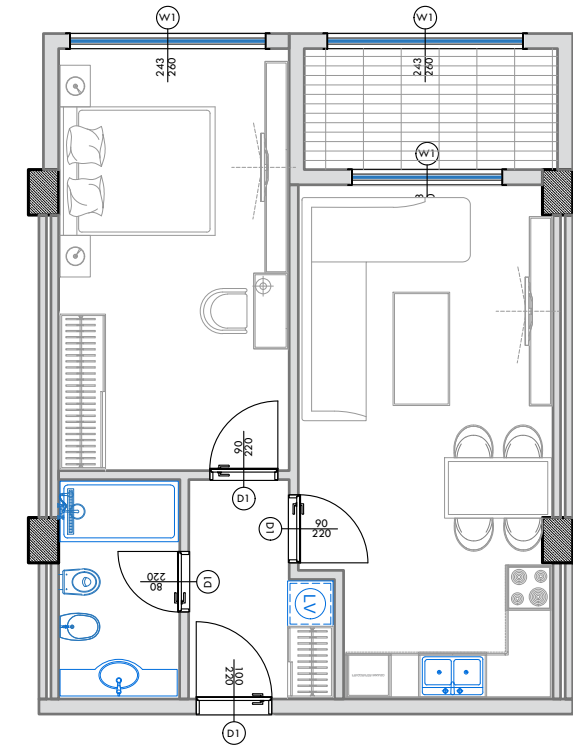
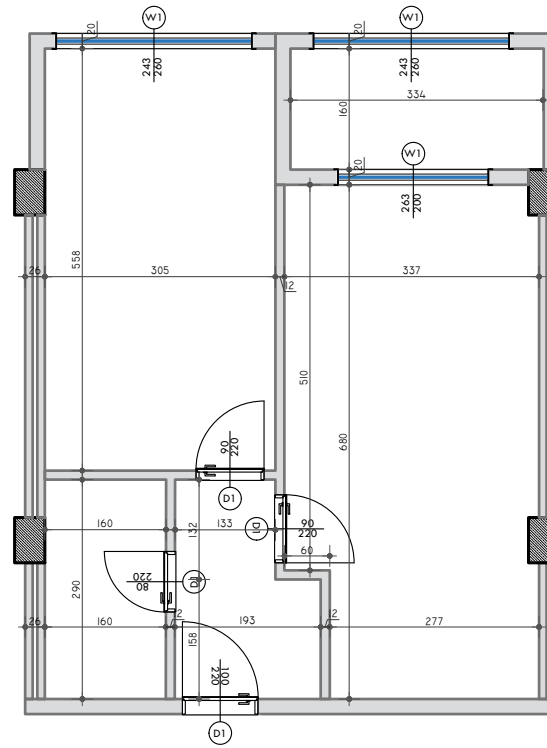

**PLANIMETRIA E APARTAMENTIT - PERMASIM**

**SHKALLA 1:100**

**PLANIMETRIA E APARTAMENTIT - MOBILIM**

**SHKALLA 1:100**

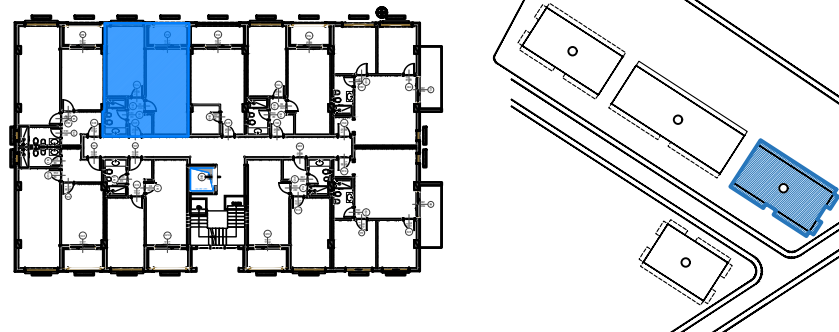

**POZICIONI I APARTAMENTIT NE PLANIMETRINE E KATIT**



**PAMJE 3 DIMENSIONALE E APARTAMENTIT**

**NR.1**



**PAMJE 3 DIMENSIONALE E APARTAMENTIT**

**NR.2**



**POZICIONI I APARTAMENTIT NE ALTIMETRI - FASADA VERIORE**

**“4 GODINA BANIMI DHE SHËRBIMI 5 KATE DHE 1 KAT PARKIM NËNTOKË”**  
**Adresa: Pavarsia e Kosovës, Golem - Bashkia Kavajë**

**INVESTITOR DHE SUBJEKT NDERTUES:**

**"LOREDIS" Sh.p.k**  
**NIPT: M32202503U**  
**Kavajë / Albania**  
**Tel: +355694080880**

**PROJEKTUES:**

**VAEKU STUDIO**  
**NIPT: M11319016N**  
**Adresa: "Kompleksi Magnet",**  
**Njësia Lyra 2018\_1**  
**Njësia Administrative Nr.7**  
**Tiranë/Albania**  
**E-mail: u.hoxha@vaeku.studio**  
**Tel: +355674088492**



**APARTAMENTI NR:**

**16**

**Objekti Nr :**

**3**

**Kati :**

**2**

**Orientimi :**

**VERI**

**Siperfaqe Apartamenti :**

**67.4 m<sup>2</sup>**

**Ambjente te perbashketa:**

**7.2 m<sup>2</sup>**

**Siperfaqe totale:**

**74.6 m<sup>2</sup>**

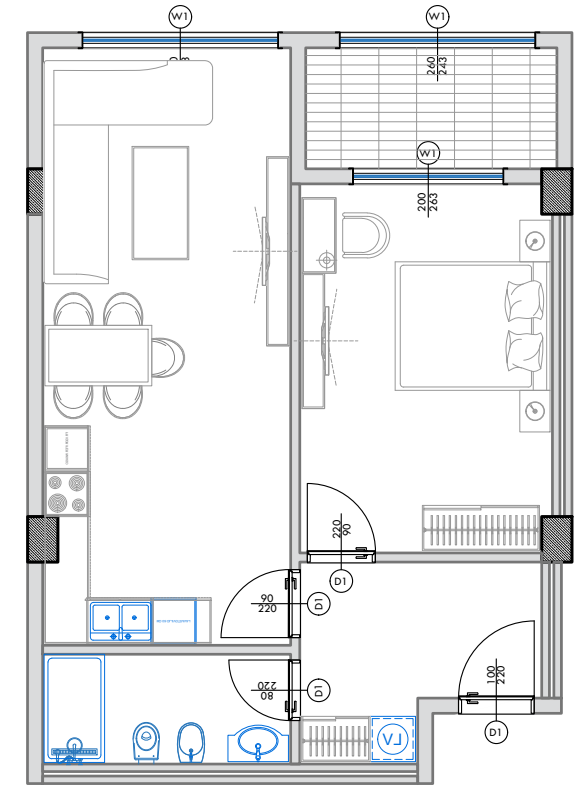
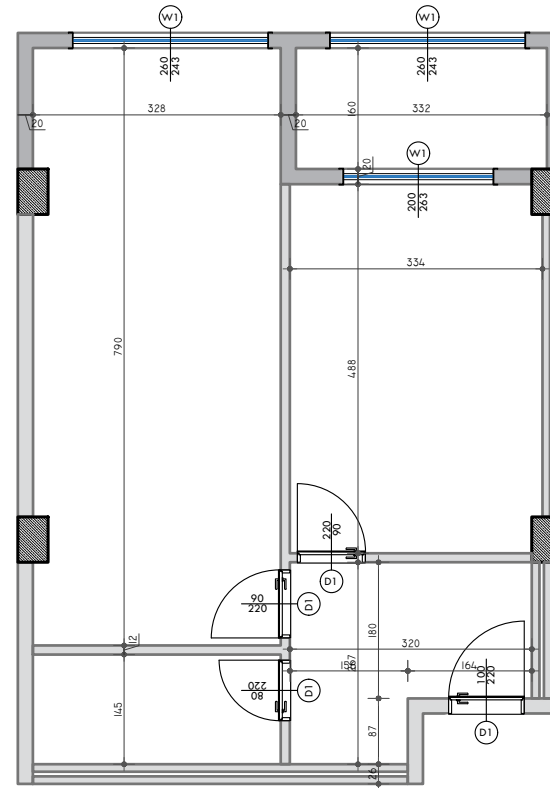

**PLANIMETRIA E APARTAMENTIT - PERMASIM**

**SHKALLA 1:100**

**PLANIMETRIA E APARTAMENTIT - MOBILIM**

**SHKALLA 1:100**

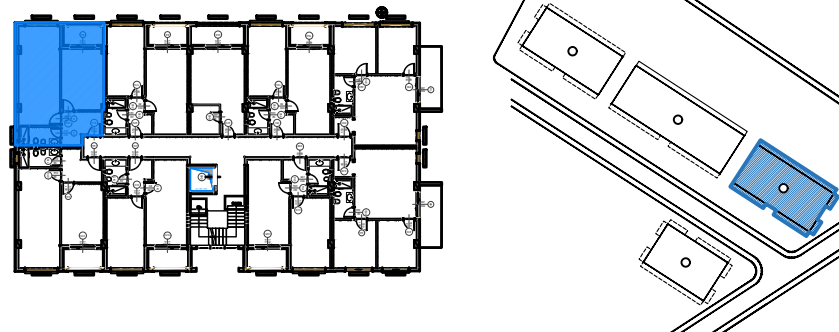

**POZICIONI I APARTAMENTIT NE PLANIMETRINE E KATIT**



**PAMJE 3 DIMENSIONALE E APARTAMENTIT**

**NR.1**



**PAMJE 3 DIMENSIONALE E APARTAMENTIT**

**NR.2**



**POZICIONI I APARTAMENTIT NE ALTIMETRI - FASADA VERIORE**





**“4 GODINA BANIMI DHE SHËRBIMI 5 KATE DHE 1 KAT PARKIM NËNTOKË”**  
**Adresa: Pavarsia e Kosovës, Golem - Bashkia Kavajë**

**INVESTITOR DHE SUBJEKT NDERTUES:**

**"LOREDIS" Sh.p.k**  
**NIPT: M32202503U**  
**Kavajë / Albania**  
**Tel: +355694080880**

**PROJEKTUES:**

**VAEKU STUDIO**  
**NIPT: M11319016N**  
**Adresa: "Kompleksi Magnet",**  
**Njësia Lyra 2018\_1**  
**Njësia Administrative Nr.7**  
**Tiranë/Albania**  
**E-mail: u.hoxha@vaeku.studio**  
**Tel: +355674088492**



**APARTAMENTI NR:**

**19**

**Objekti Nr :**

**3**

**Kati :**

**3**

**Orientimi :**

**JUG**

**Siperfaqe Apartamenti :**

**61.0 m<sup>2</sup>**

**Ambjente te perbashketa:**

**6.5 m<sup>2</sup>**

**Siperfaqe totale:**

**67.5 m<sup>2</sup>**



**SHITUR RRAHMANI**

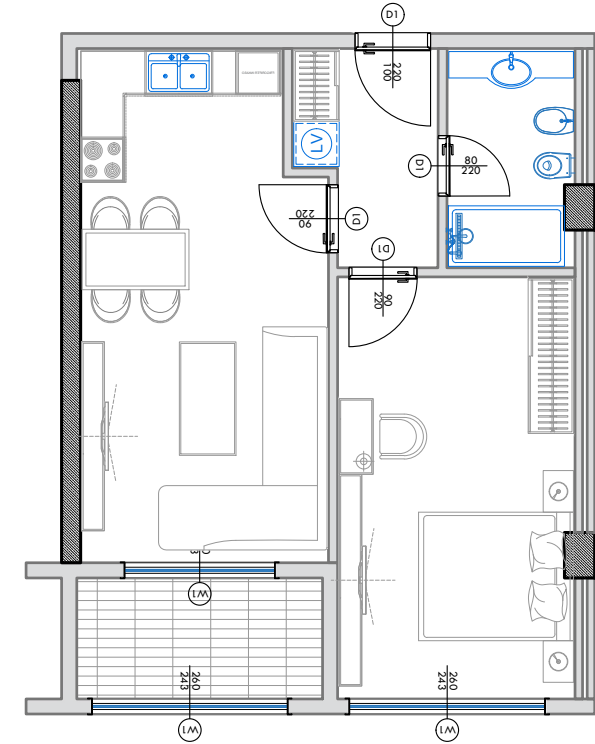
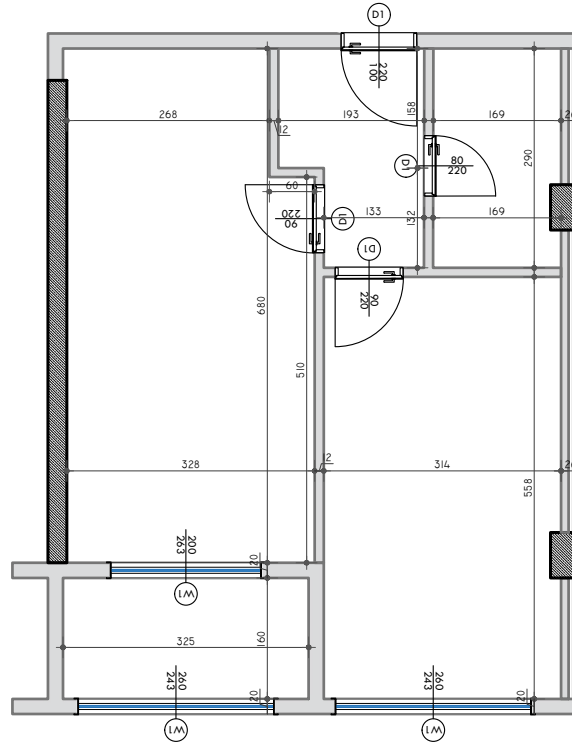

**PLANIMETRIA E APARTAMENTIT - PERMASIM**

**SHKALLA 1:100**

**PLANIMETRIA E APARTAMENTIT - MOBILIM**

**SHKALLA 1:100**

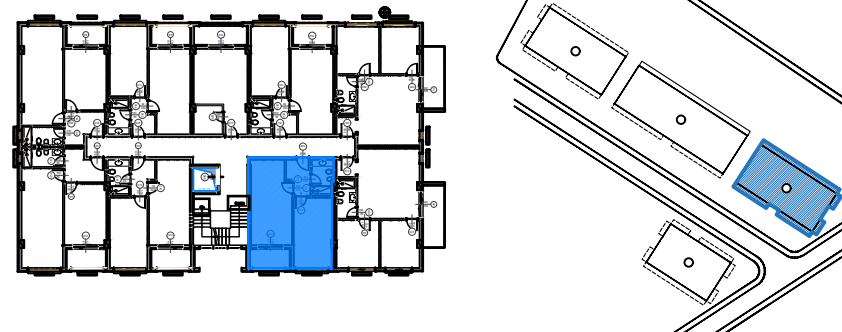

**POZICIONI I APARTAMENTIT NE PLANIMETRINE E KATIT**



**POZICIONI I APARTAMENTIT NE ALTIMETRI -JUGORE**



**PAMJE 3 DIMENSIONALE E APARTAMENTIT**

**NR.1**



**PAMJE 3 DIMENSIONALE E APARTAMENTIT**

**NR.2**

**“4 GODINA BANIMI DHE SHËRBIMI 5 KATE DHE 1 KAT PARKIM NËNTOKË”**  
**Adresa: Pavarsia e Kosovës, Golem - Bashkia Kavajë**

**INVESTITOR DHE SUBJEKT NDERTUES:**

**"LOREDIS" Sh.p.k**  
**NIPT: M32202503U**  
**Kavajë / Albania**  
**Tel: +355694080880**

**PROJEKTUES:**

**VAEKU STUDIO**  
**NIPT: M11319016N**  
**Adresa: "Kompleksi Magnet",**  
**Njësia Lyra 2018\_1**  
**Njësia Administrative Nr.7**  
**Tiranë/Albania**  
**E-mail: u.hoxha@vaeku.studio**  
**Tel: +355674088492**



**APARTAMENTI NR:**

**20**

**Objekti Nr :**

**3**

**Kati :**

**3**

**Orientimi :**

**JUG**

**Siperfaqe Apartamenti :**

**67.4 m<sup>2</sup>**

**Ambjente te perbashketa:**

**7.2 m<sup>2</sup>**

**Siperfaqe totale:**

**74.6 m<sup>2</sup>**

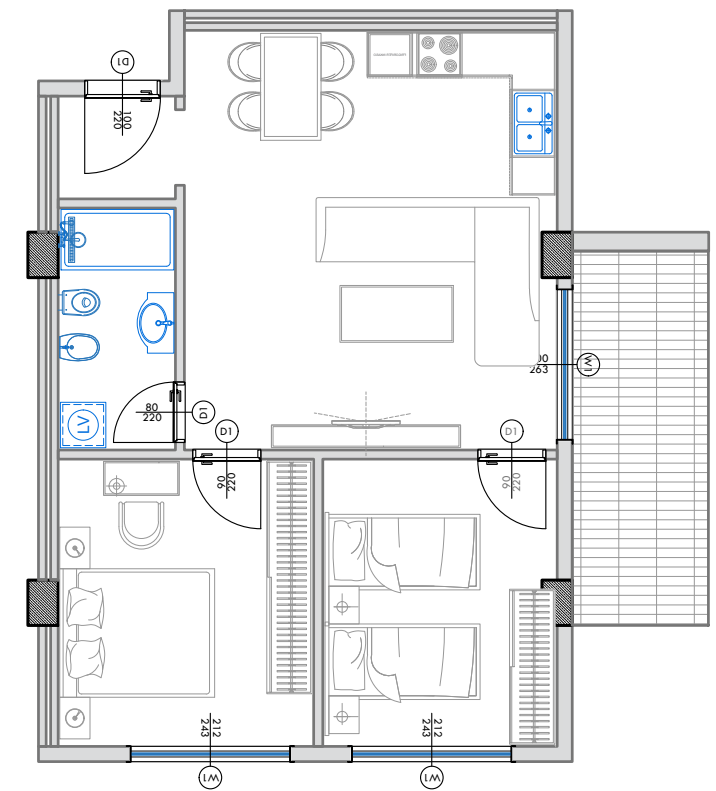
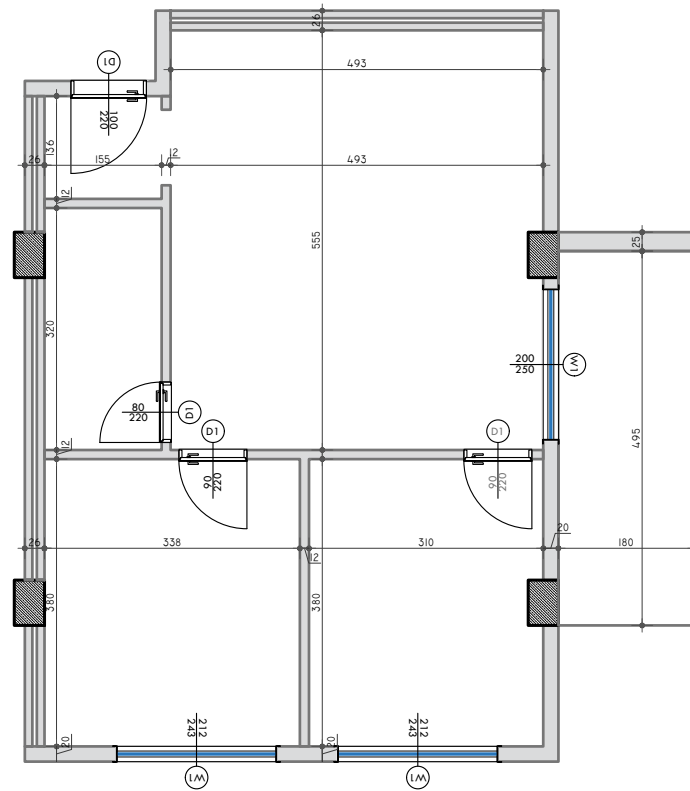

**PLANIMETRIA E APARTAMENTIT - PERMASIM**

**SHKALLA 1:100**

**PLANIMETRIA E APARTAMENTIT - MOBILIM**

**SHKALLA 1:100**

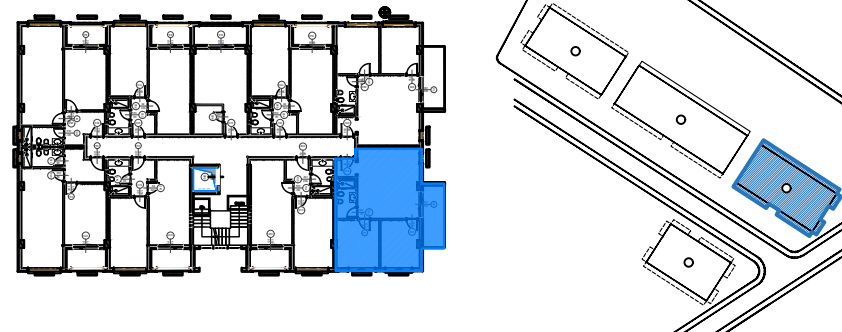

**POZICIONI I APARTAMENTIT NE PLANIMETRINE E KATIT**



**POZICIONI I APARTAMENTIT NE ALTIMETRI - FASADA JUGORE**



**PAMJE 3 DIMENSIONALE E APARTAMENTIT**

**NR.1**



**PAMJE 3 DIMENSIONALE E APARTAMENTIT**

**NR.2**



**“4 GODINA BANIMI DHE SHËRBIMI 5 KATE DHE 1 KAT PARKIM NËNTOKË”**  
**Adresa: Pavarsia e Kosovës, Golem - Bashkia Kavajë**

**INVESTITOR DHE SUBJEKT NDERTUES:**

**"LOREDIS" Sh.p.k**  
**NIPT: M32202503U**  
**Kavajë / Albania**  
**Tel: +355694080880**

**PROJEKTUES:**

**VAEKU STUDIO**  
**NIPT: M11319016N**  
**Adresa: "Kompleksi Magnet",**  
**Njësia Lyra 2018\_1**  
**Njësia Administrative Nr.7**  
**Tiranë/Albania**  
**E-mail: u.hoxha@vaeku.studio**  
**Tel: +355674088492**



**APARTAMENTI NR:**

**22**

**Objekti Nr :**

**3**

**Kati :**

**3**

**Orientimi :**

**VERI**

**Siperfaqe Apartamenti :**

**61.0 m<sup>2</sup>**

**Ambjente te perbashketa:**

**6.5 m<sup>2</sup>**

**Siperfaqe totale:**

**67.5 m<sup>2</sup>**

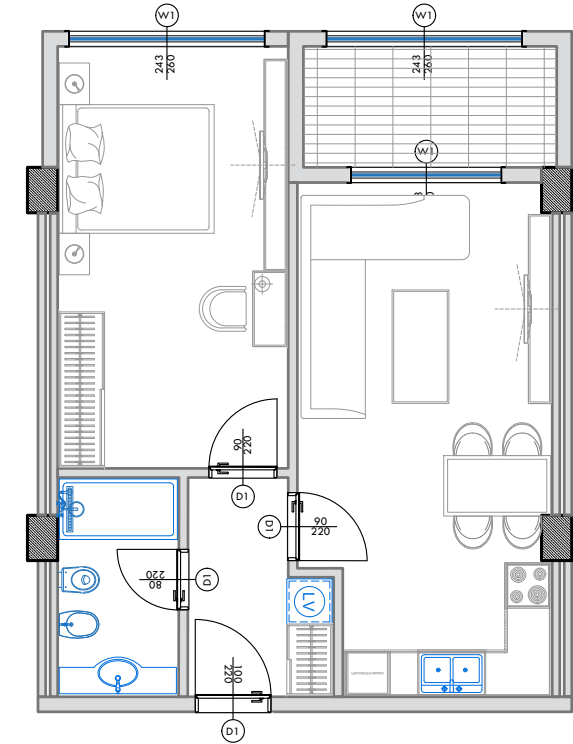
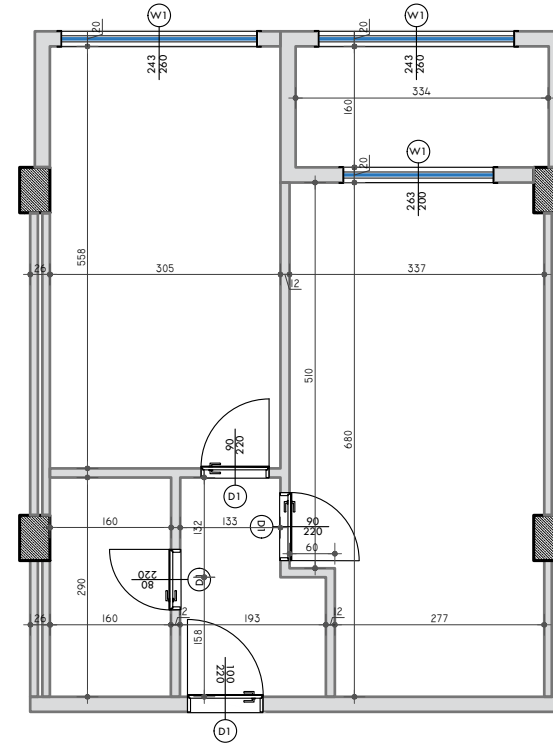

**PLANIMETRIA E APARTAMENTIT - PERMASIM**

**SHKALLA 1:100**

**PLANIMETRIA E APARTAMENTIT - MOBILIM**

**SHKALLA 1:100**

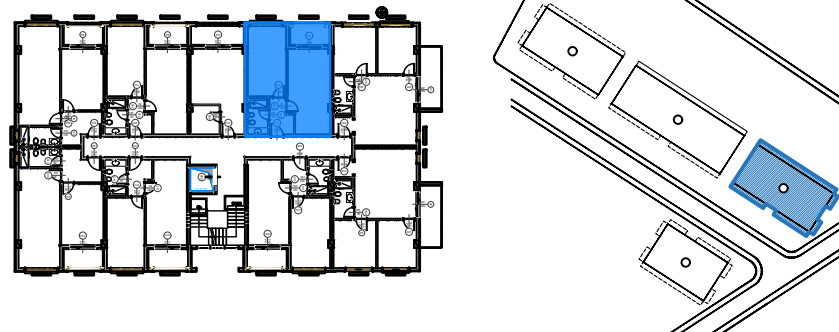

**POZICIONI I APARTAMENTIT NE PLANIMETRINE E KATIT**



**PAMJE 3 DIMENSIONALE E APARTAMENTIT**

**NR.1**



**PAMJE 3 DIMENSIONALE E APARTAMENTIT**

**NR.2**

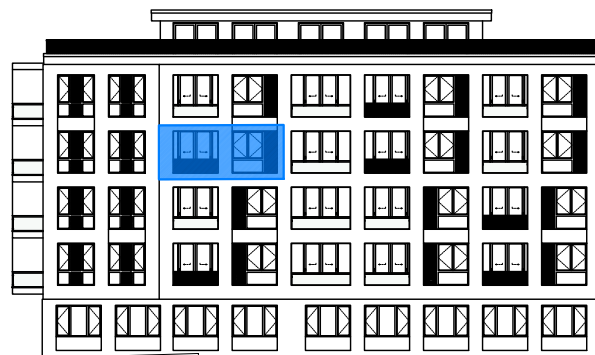

**POZICIONI I APARTAMENTIT NE ALTIMETRI - FASADA VERIORE**



**“4 GODINA BANIMI DHE SHËRBIMI 5 KATE DHE 1 KAT PARKIM NËNTOKË”**  
**Adresa: Pavarsia e Kosovës, Golem - Bashkia Kavajë**

**INVESTITOR DHE SUBJEKT NDERTUES:**

**"LOREDIS" Sh.p.k**  
**NIPT: M32202503U**  
**Kavajë / Albania**  
**Tel: +355694080880**

**PROJEKTUES:**

**VAEKU STUDIO**  
**NIPT: M11319016N**  
**Adresa: "Kompleksi Magnet",**  
**Njësia Lyra 2018\_1**  
**Njësia Administrative Nr.7**  
**Tiranë/Albania**  
**E-mail: u.hoxha@vaeku.studio**  
**Tel: +355674088492**



APARTAMENTI NR:	<b>23</b>
Objekti Nr :	3
Kati :	3
Orientimi :	VERI
Siperfaqe Apartamenti :	40.5 m <sup>2</sup>
Ambjente te perbashketa:	4.4 m <sup>2</sup>
Siperfaqe totale:	44.9 m <sup>2</sup>



**SHITUR B**

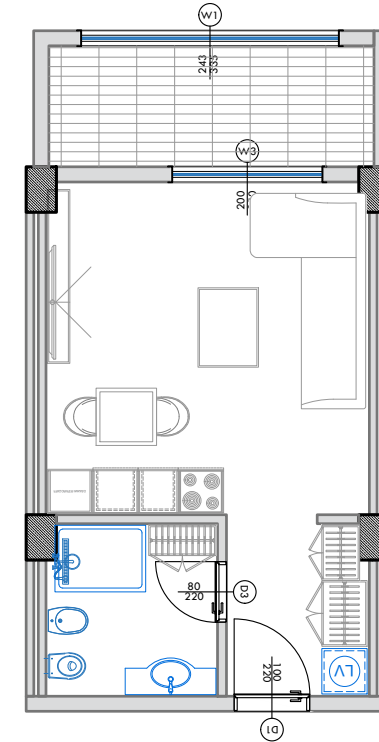
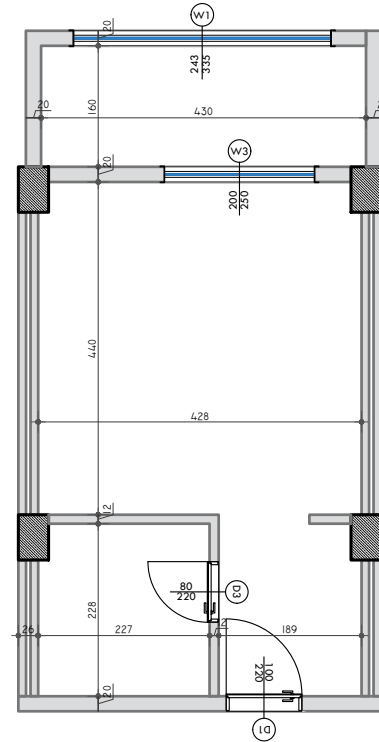

**PLANIMETRIA E APARTAMENTIT - PERMASIM**

**SHKALLA 1:100**

**PLANIMETRIA E APARTAMENTIT - MOBILIM**

**SHKALLA 1:100**

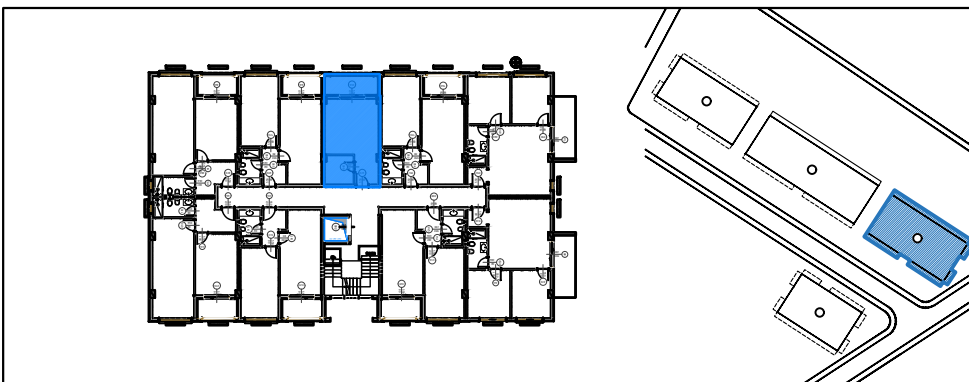

**POZICIONI I APARTAMENTIT NE PLANIMETRINE E KATIT**

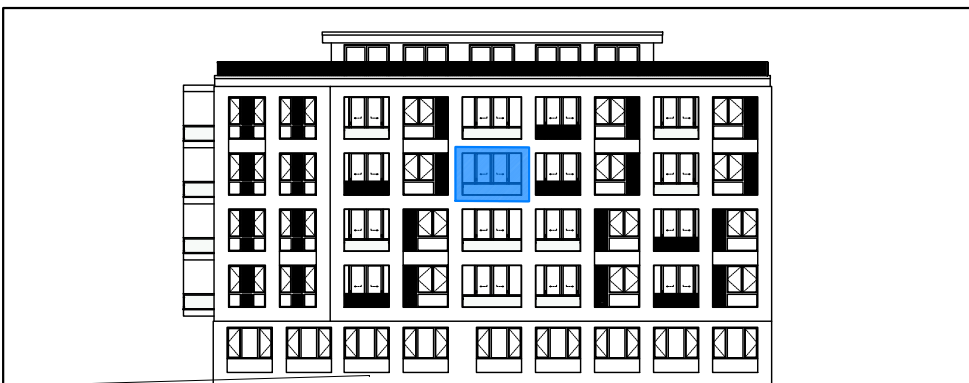

**POZICIONI I APARTAMENTIT NE ALTIMETRI - FASADA VERIORE**

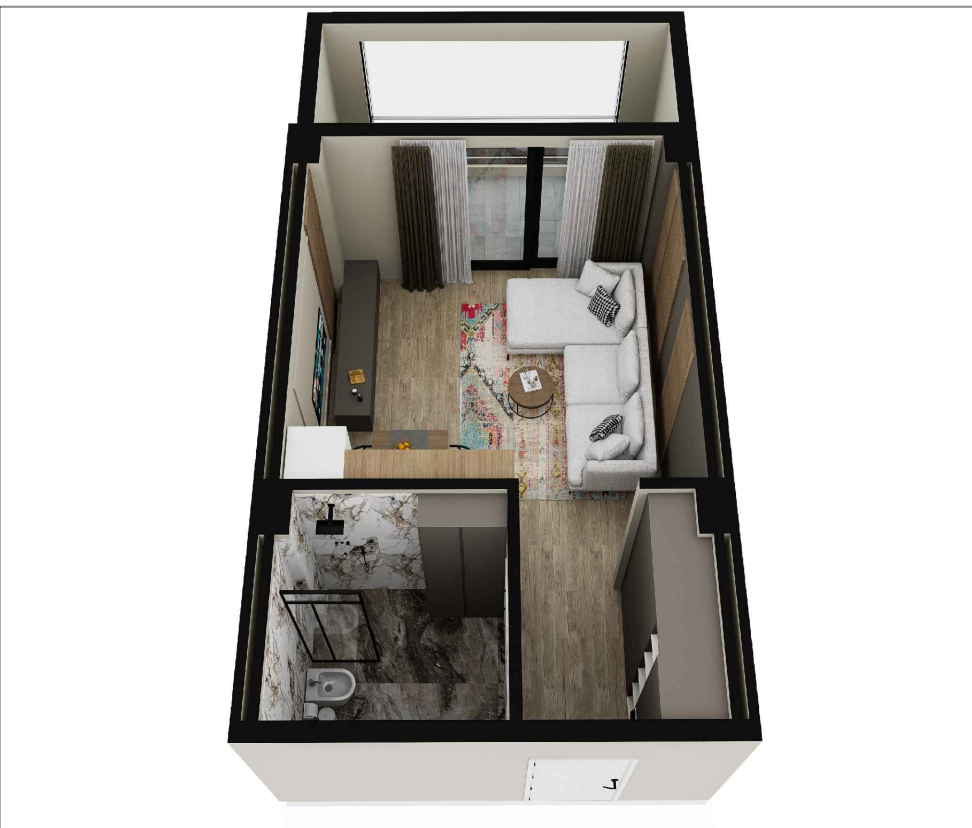

**PAMJE 3 DIMENSIONALE E APARTAMENTIT**

**NR.1**



**PAMJE 3 DIMENSIONALE E APARTAMENTIT**

**NR.2**



**“4 GODINA BANIMI DHE SHËRBIMI 5 KATE DHE 1 KAT PARKIM NËNTOKË”**  
**Adresa: Pavarsia e Kosovës, Golem - Bashkia Kavajë**

**INVESTITOR DHE SUBJEKT NDERTUES:**

**"LOREDIS" Sh.p.k**  
**NIPT: M32202503U**  
**Kavajë / Albania**  
**Tel: +355694080880**

**PROJEKTUES:**

**VAEKU STUDIO**  
**NIPT: M11319016N**  
**Adresa: "Kompleksi Magnet",**  
**Njësia Lyra 2018\_1**  
**Njësia Administrative Nr.7**  
**Tiranë/Albania**  
**E-mail: u.hoxha@vaeku.studio**  
**Tel: +355674088492**



**APARTAMENTI NR:**

**25**

**Objekti Nr :**

**3**

**Kati :**

**3**

**Orientimi :**

**VERI**

**Siperfaqe Apartamenti :**

**67.4 m<sup>2</sup>**

**Ambjente te perbashketa:**

**7.2 m<sup>2</sup>**

**Siperfaqe totale:**

**74.6 m<sup>2</sup>**

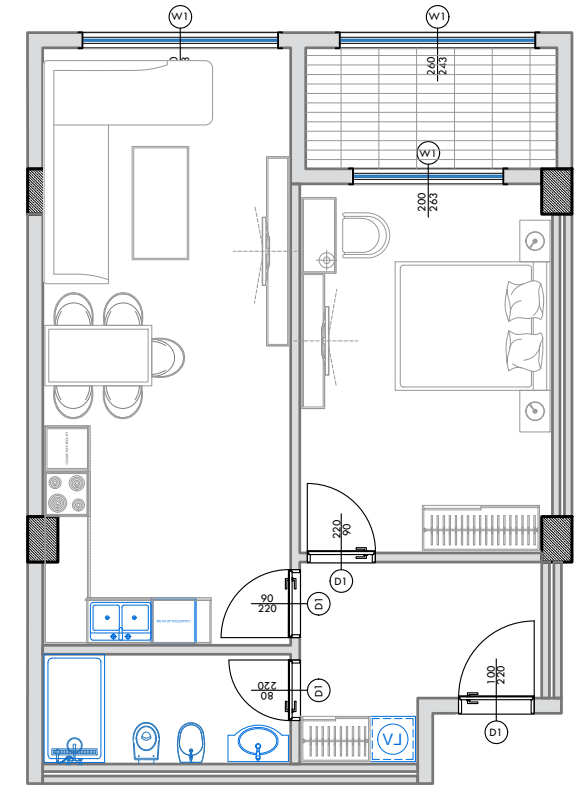
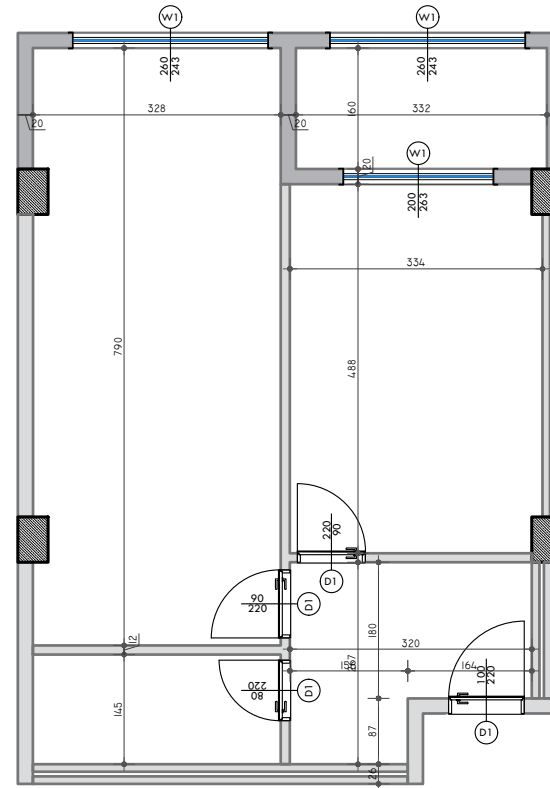

**PLANIMETRIA E APARTAMENTIT - PERMASIM**

**SHKALLA 1:100**

**PLANIMETRIA E APARTAMENTIT - MOBILIM**

**SHKALLA 1:100**

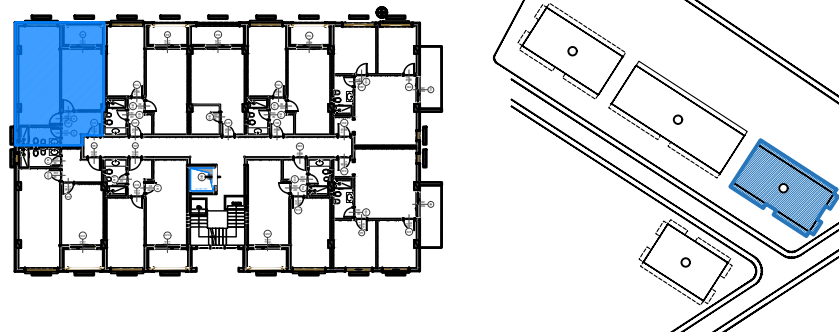

**POZICIONI I APARTAMENTIT NE PLANIMETRINE E KATIT**



**PAMJE 3 DIMENSIONALE E APARTAMENTIT**

**NR.1**



**PAMJE 3 DIMENSIONALE E APARTAMENTIT**

**NR.2**



**POZICIONI I APARTAMENTIT NE ALTIMETRI - FASADA VERIORE**



**“4 GODINA BANIMI DHE SHËRBIMI 5 KATE DHE 1 KAT PARKIM NËNTOKË”**  
**Adresa: Pavarsia e Kosovës, Golem - Bashkia Kavajë**

**INVESTITOR DHE SUBJEKT NDERTUES:**

**"LOREDIS" Sh.p.k**  
**NIPT: M32202503U**  
**Kavajë / Albania**  
**Tel: +355694080880**

**PROJEKTUES:**

**VAEKU STUDIO**  
**NIPT: M11319016N**  
**Adresa: "Kompleksi Magnet",**  
**Njësia Lyra 2018\_1**  
**Njësia Administrative Nr.7**  
**Tiranë/Albania**  
**E-mail: u.hoxha@vaeku.studio**  
**Tel: +355674088492**



**APARTAMENTI NR:**

**27**

**Objekti Nr :**

**3**

**Kati :**

**3**

**Orientimi :**

**JUG**

**Siperfaqe Apartamenti :**

**61.0 m<sup>2</sup>**

**Ambjente te perbashketa:**

**6.5 m<sup>2</sup>**

**Siperfaqe totale:**

**67.5 m<sup>2</sup>**

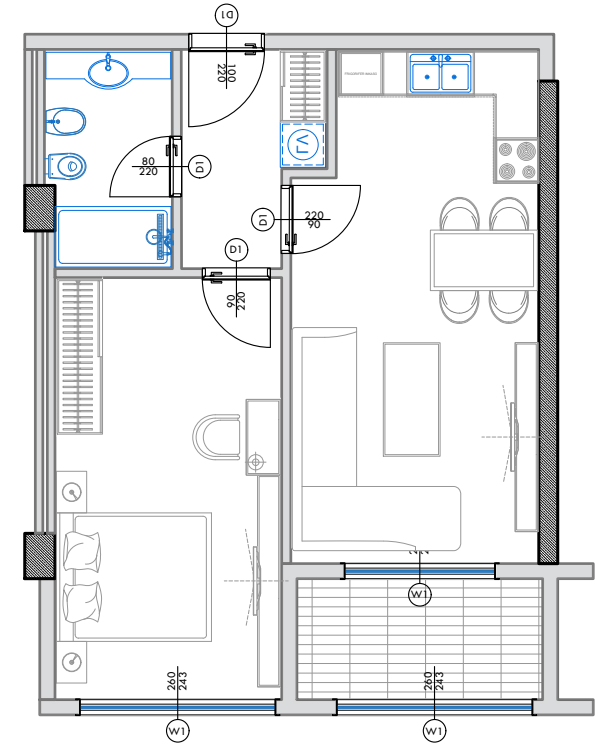
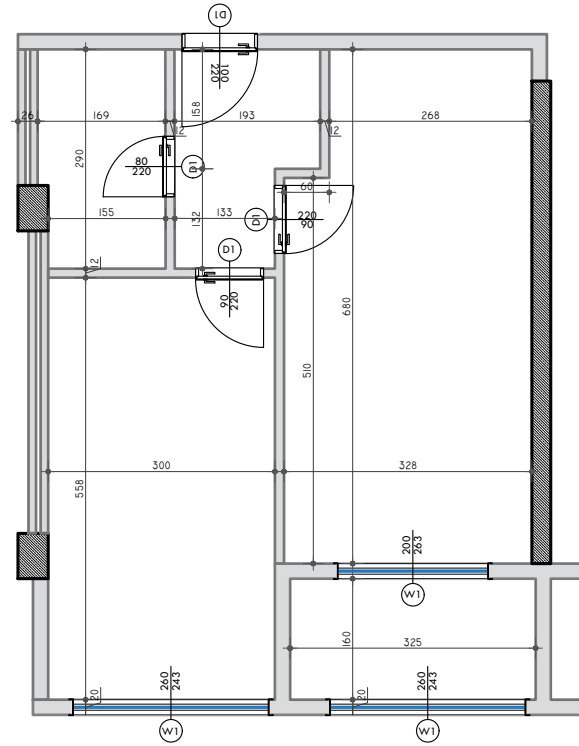

**PLANIMETRIA E APARTAMENTIT - PERMASIM**

**SHKALLA 1:100**

**PLANIMETRIA E APARTAMENTIT - MOBILIM**

**SHKALLA 1:100**

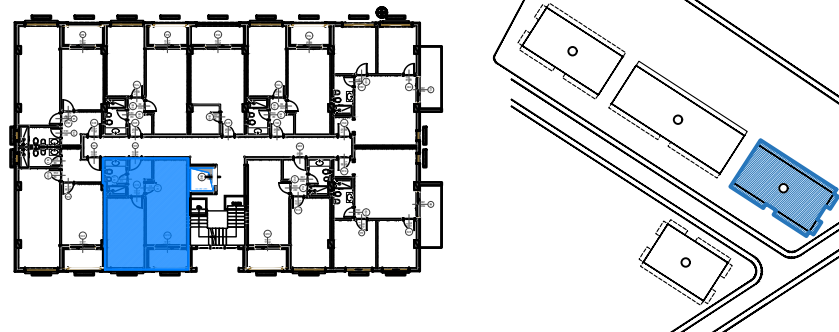

**POZICIONI I APARTAMENTIT NE PLANIMETRINE E KATIT**



**POZICIONI I APARTAMENTIT NE ALTIMETRI - FASADA JUGORE**



**PAMJE 3 DIMENSIONALE E APARTAMENTIT**

**NR.1**



**PAMJE 3 DIMENSIONALE E APARTAMENTIT**

**NR.2**

**“4 GODINA BANIMI DHE SHËRBIMI 5 KATE DHE 1 KAT PARKIM NËNTOKË”**  
**Adresa: Pavarsia e Kosovës, Golem - Bashkia Kavajë**

**INVESTITOR DHE SUBJEKT NDERTUES:**

**"LOREDIS" Sh.p.k**  
**NIPT: M32202503U**  
**Kavajë / Albania**  
**Tel: +355694080880**

**PROJEKTUES:**

**VAEKU STUDIO**  
**NIPT: M11319016N**  
**Adresa: "Kompleksi Magnet",**  
**Njësia Lyra 2018\_1**  
**Njësia Administrative Nr.7**  
**Tiranë/Albania**  
**E-mail: u.hoxha@vaeku.studio**  
**Tel: +355674088492**



**SHITUR RRAHMANI**

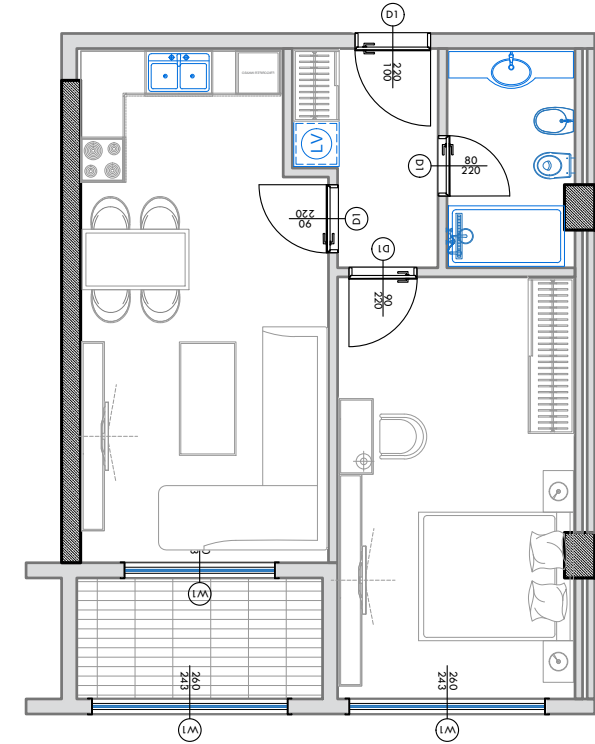
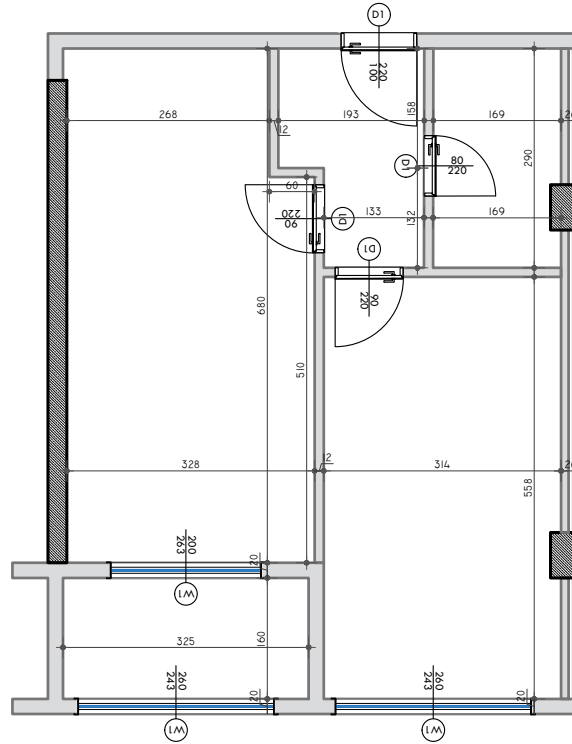

APARTAMENTI NR:	<b>28</b>
Objekti Nr :	3
Kati :	4
Orientimi :	JUG
Siperfaqe Apartamenti :	61.0 m <sup>2</sup>
Ambjente te perbashketa:	6.5 m <sup>2</sup>
Siperfaqe totale:	67.5 m <sup>2</sup>



**PLANIMETRIA E APARTAMENTIT - PERMASIM**

**SHKALLA 1:100**

**PLANIMETRIA E APARTAMENTIT - MOBILIM**

**SHKALLA 1:100**

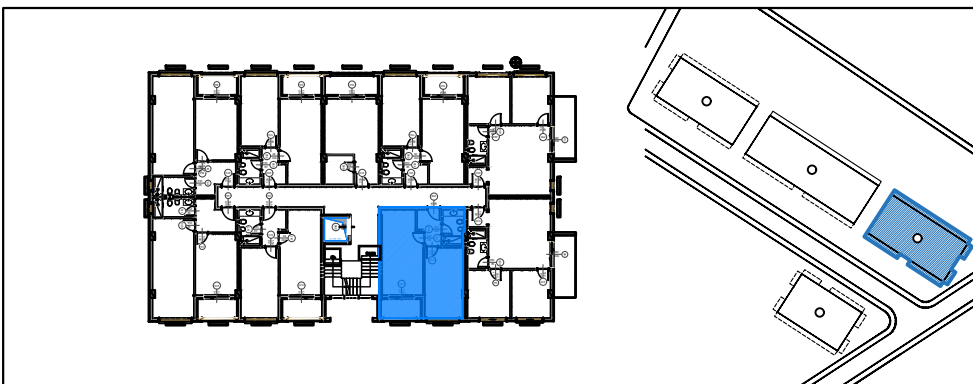

**POZICIONI I APARTAMENTIT NE PLANIMETRINE E KATIT**



**POZICIONI I APARTAMENTIT NE ALTIMETRI -JUGORE**



**PAMJE 3 DIMENSIONALE E APARTAMENTIT**

**NR.1**



**PAMJE 3 DIMENSIONALE E APARTAMENTIT**

**NR.2**

**"4 GODINA BANIMI DHE SHËRBIMI 5 KATE DHE 1 KAT PARKIM NËNTOKË"**  
Adresa: Pavorsia e Kosovës, Golem - Bashkia Kavajë

**INVESTITOR DHE SUBJEKT NDERTUES:**

**"LOREDIS" Sh.p.k**  
NIPT: M32202503U  
Kavajë / Albania  
Tel: +355694080880

**PROJEKTUES:**

**VAEKU STUDIO**  
NIPT: M11319016N  
Adresa: "Kompleksi Magnet",  
Njësia Lyra 2018\_1  
Njësia Administrative Nr.7  
Tiranë/Albania  
E-mail: u.hoxha@vaeu.studio  
Tel: +355674088492



APARTAMENTI NR:

**29**

Objekti Nr :

3

Kati :

4

Orientimi :

JUG

Siperfaqe Apartamenti :

67.4 m<sup>2</sup>

Ambjente te perbashketa:

7.2 m<sup>2</sup>

Siperfaqe totale:

74.6 m<sup>2</sup>

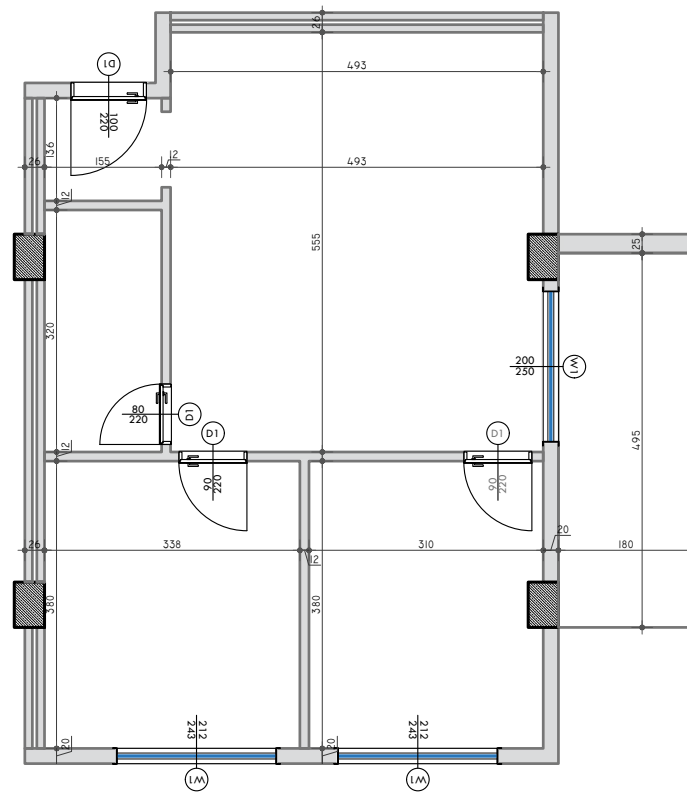

**PLANIMETRIA E APARTAMENTIT - PERMASIM**

**SHKALLA 1:100**

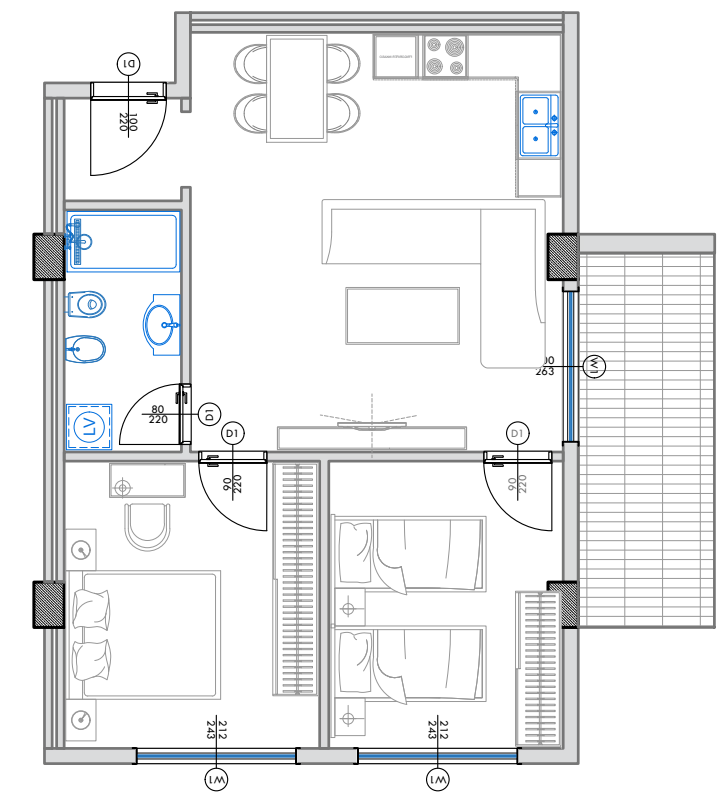

**PLANIMETRIA E APARTAMENTIT - MOBILIM**

**SHKALLA 1:100**

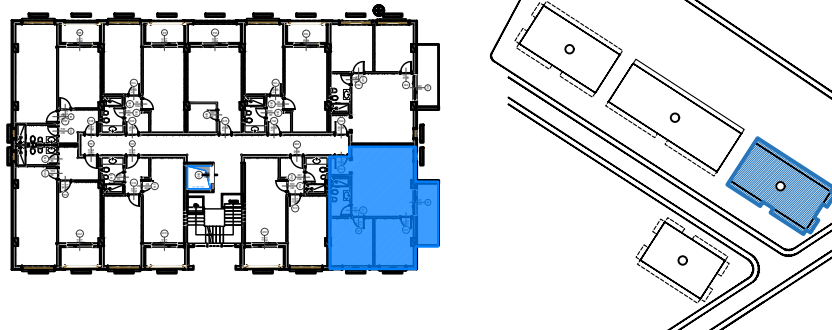

**POZICIONI I APARTAMENTIT NE PLANIMETRINE E KATIT**



**POZICIONI I APARTAMENTIT NE ALTIMETRI - FASADA JUGORE**



**PAMJE 3 DIMENSIONALE E APARTAMENTIT**

**NR.1**



**PAMJE 3 DIMENSIONALE E APARTAMENTIT**

**NR.2**

**“4 GODINA BANIMI DHE SHËRBIMI 5 KATE DHE 1 KAT PARKIM NËNTOKË”**  
**Adresa: Pavarsia e Kosovës, Golem - Bashkia Kavajë**

**INVESTITOR DHE SUBJEKT NDERTUES:**

**“LOREDIS” Sh.p.k**  
**NIPT: M32202503U**  
**Kavajë / Albania**  
**Tel: +355694080880**

**PROJEKTUES:**

**VAEKU STUDIO**  
**NIPT: M11319016N**  
**Adresa: “Kompleksi Magnet”,**  
**Njësia Lyra 2018\_1**  
**Njësia Administrative Nr.7**  
**Tiranë/Albania**  
**E-mail: u.hoxha@vaeku.studio**  
**Tel: +355674088492**



**APARTAMENTI NR:**

**30**

**Objekti Nr :**

**3**

**Kati :**

**4**

**Orientimi :**

**VERI**

**Siperfaqe Apartamenti :**

**67.4 m<sup>2</sup>**

**Ambjente te perbashketa:**

**7.2 m<sup>2</sup>**

**Siperfaqe totale:**

**74.6 m<sup>2</sup>**

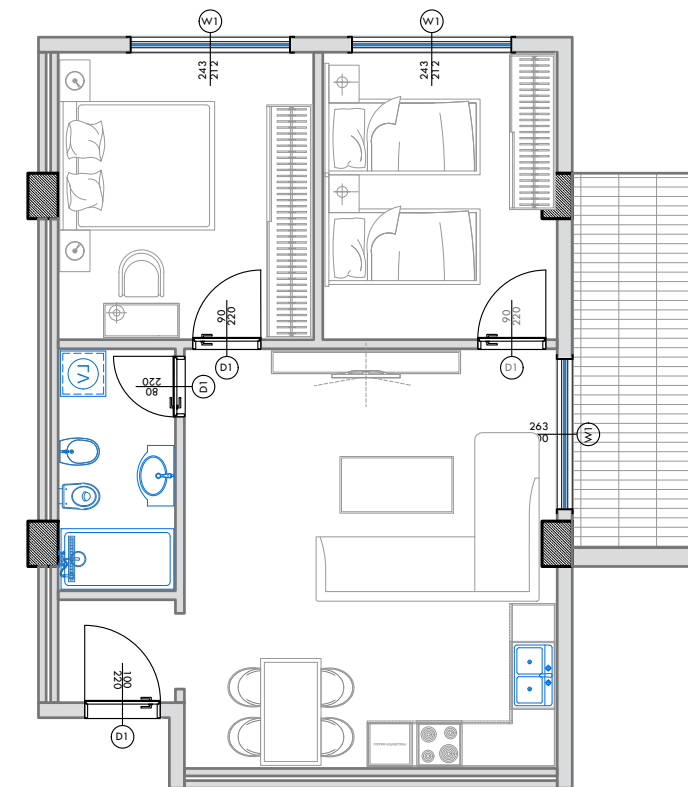
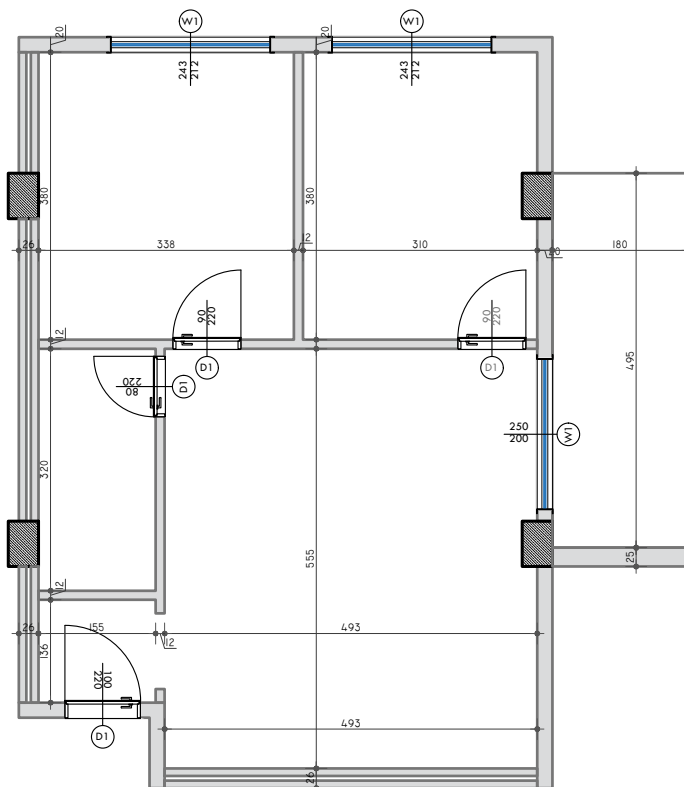

**PLANIMETRIA E APARTAMENTIT - PERMASIM**

**SHKALLA 1:100**

**PLANIMETRIA E APARTAMENTIT - MOBILIM**

**SHKALLA 1:100**

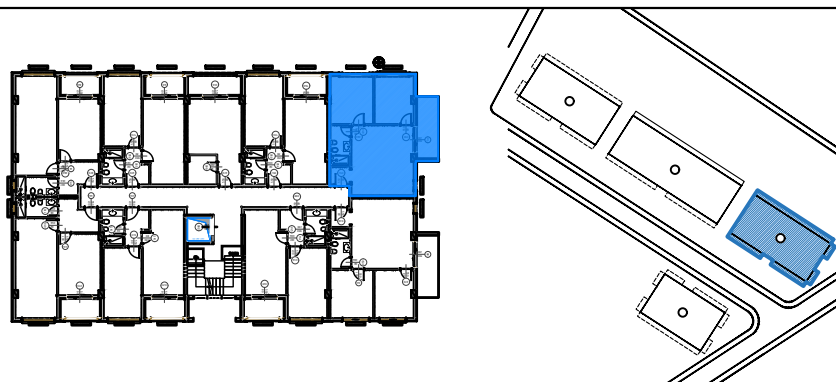

**POZICIONI I APARTAMENTIT NE PLANIMETRINE E KATIT**



**POZICIONI I APARTAMENTIT NE ALTIMETRI - FASADA VERIORE**



**PAMJE 3 DIMENSIONALE E APARTAMENTIT**

**NR.1**



**PAMJE 3 DIMENSIONALE E APARTAMENTIT**

**NR.2**



**“4 GODINA BANIMI DHE SHËRBIMI 5 KATE DHE 1 KAT PARKIM NËNTOKË”**  
**Adresa: Pavarsia e Kosovës, Golem - Bashkia Kavajë**

**INVESTITOR DHE SUBJEKT NDERTUES:**

**"LOREDIS" Sh.p.k**  
**NIPT: M32202503U**  
**Kavajë / Albania**  
**Tel: +355694080880**

**PROJEKTUES:**

**VAEKU STUDIO**  
**NIPT: M11319016N**  
**Adresa: "Kompleksi Magnet",**  
**Njësia Lyra 2018\_1**  
**Njësia Administrative Nr.7**  
**Tiranë/Albania**  
**E-mail: u.hoxha@vaeku.studio**  
**Tel: +355674088492**



**APARTAMENTI NR:**

**31**

**Objekti Nr :**

**3**

**Kati :**

**4**

**Orientimi :**

**VERI**

**Siperfaqe Apartamenti :**

**61.0 m<sup>2</sup>**

**Ambjente te perbashketa:**

**6.5 m<sup>2</sup>**

**Siperfaqe totale:**

**67.5 m<sup>2</sup>**

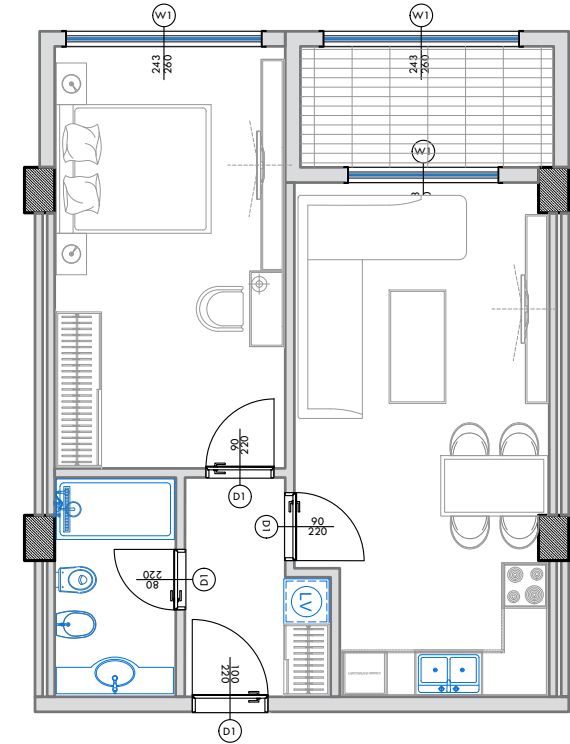
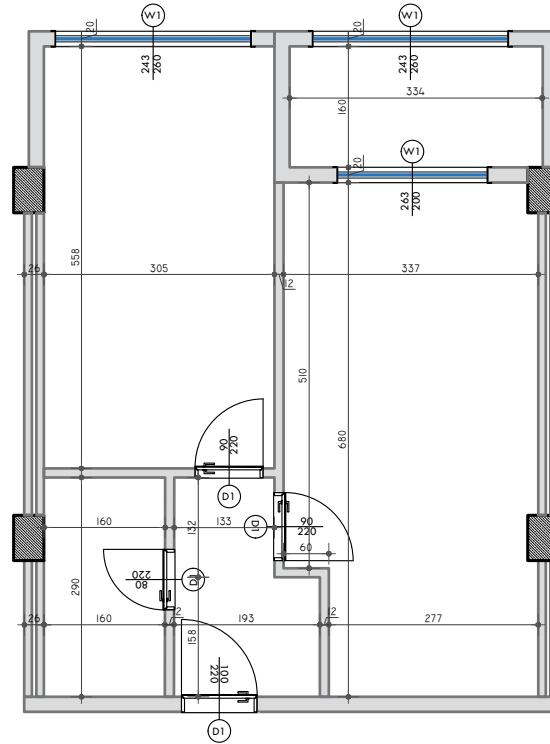

**PLANIMETRIA E APARTAMENTIT - PERMASIM**

**SHKALLA 1:100**

**PLANIMETRIA E APARTAMENTIT - MOBILIM**

**SHKALLA 1:100**

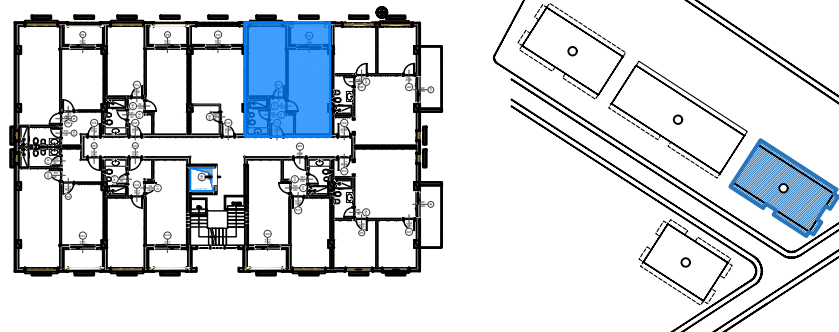

**POZICIONI I APARTAMENTIT NE PLANIMETRINE E KATIT**



**PAMJE 3 DIMENSIONALE E APARTAMENTIT**

**NR.1**



**PAMJE 3 DIMENSIONALE E APARTAMENTIT**

**NR.2**



**POZICIONI I APARTAMENTIT NE ALTIMETRI - FASADA VERIORE**

**“4 GODINA BANIMI DHE SHËRBIMI 5 KATE DHE 1 KAT PARKIM NËNTOKË”**  
**Adresa: Pavarsia e Kosovës, Golem - Bashkia Kavajë**

**INVESTITOR DHE SUBJEKT NDERTUES:**

**"LOREDIS" Sh.p.k**  
**NIPT: M32202503U**  
**Kavajë / Albania**  
**Tel: +355694080880**

**PROJEKTUES:**

**VAEKU STUDIO**  
**NIPT: M11319016N**  
**Adresa: "Kompleksi Magnet",**  
**Njësia Lyra 2018\_1**  
**Njësia Administrative Nr.7**  
**Tiranë/Albania**  
**E-mail: u.hoxha@vaeku.studio**  
**Tel: +355674088492**



# SHITUR B

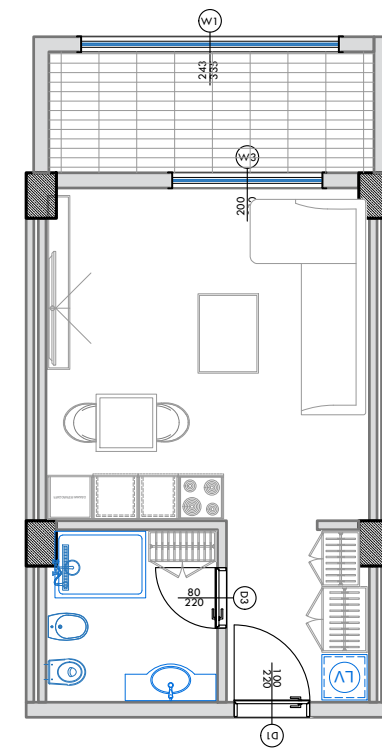
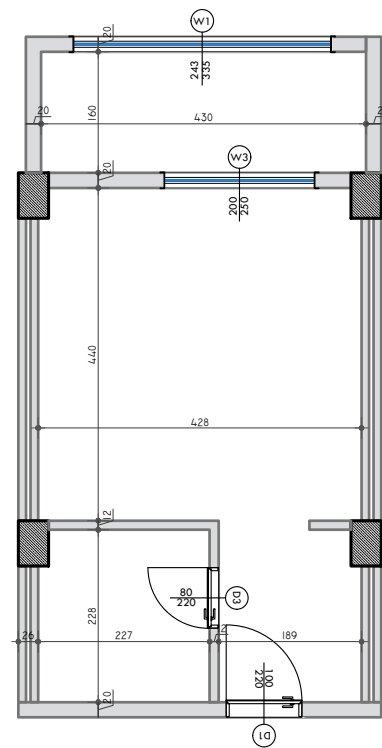

APARTAMENTI NR:	<b>32</b>
Objekti Nr :	3
Kati :	4
Orientimi :	VERI
Siperfaqe Apartamenti :	40.5 m <sup>2</sup>
Ambjente te perbashketa:	4.4 m <sup>2</sup>
Siperfaqe totale:	44.9 m <sup>2</sup>



**PLANIMETRIA E APARTAMENTIT - PERMASIM**

**SHKALLA 1:100**

**PLANIMETRIA E APARTAMENTIT - MOBILIM**

**SHKALLA 1:100**

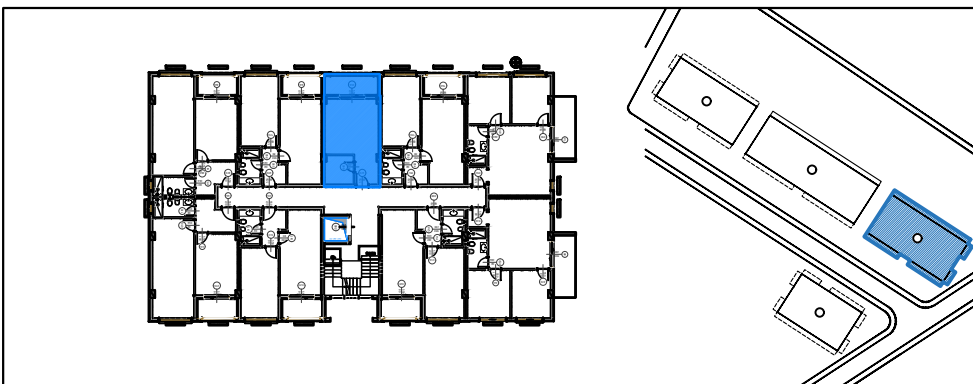

**POZICIONI I APARTAMENTIT NE PLANIMETRINE E KATIT**

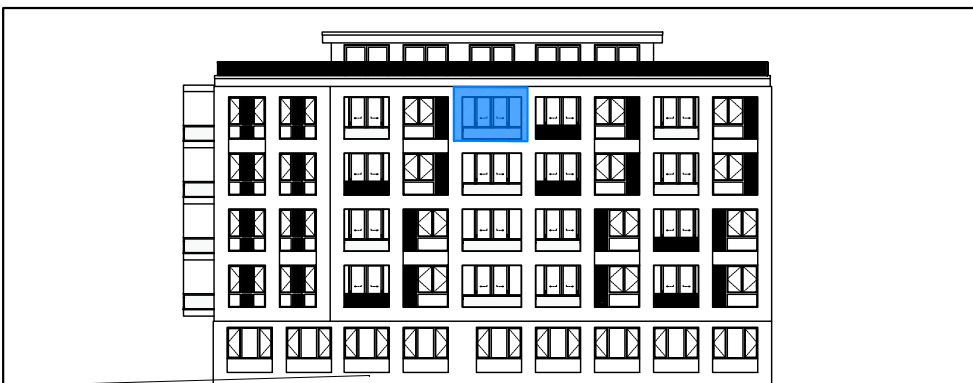

**POZICIONI I APARTAMENTIT NE ALTIMETRI - FASADA VERIORE**



**PAMJE 3 DIMENSIONALE E APARTAMENTIT**

**NR.1**



**PAMJE 3 DIMENSIONALE E APARTAMENTIT**

**NR.2**

**“4 GODINA BANIMI DHE SHËRBIMI 5 KATE DHE 1 KAT PARKIM NËNTOKË”**  
**Adresa: Pavarsia e Kosovës, Golem - Bashkia Kavajë**

**INVESTITOR DHE SUBJEKT NDERTUES:**

**"LOREDIS" Sh.p.k**  
**NIPT: M32202503U**  
**Kavajë / Albania**  
**Tel: +355694080880**

**PROJEKTUES:**

**VAEKU STUDIO**  
**NIPT: M11319016N**  
**Adresa: "Kompleksi Magnet",**  
**Njësia Lyra 2018\_1**  
**Njësia Administrative Nr.7**  
**Tiranë/Albania**  
**E-mail: u.hoxha@vaeku.studio**  
**Tel: +355674088492**



**APARTAMENTI NR:**

**33**

**Objekti Nr :**

**3**

**Kati :**

**4**

**Orientimi :**

**VERI**

**Siperfaqe Apartamenti :**

**61.0 m<sup>2</sup>**

**Ambjente te perbashketa:**

**6.5 m<sup>2</sup>**

**Siperfaqe totale:**

**67.5 m<sup>2</sup>**

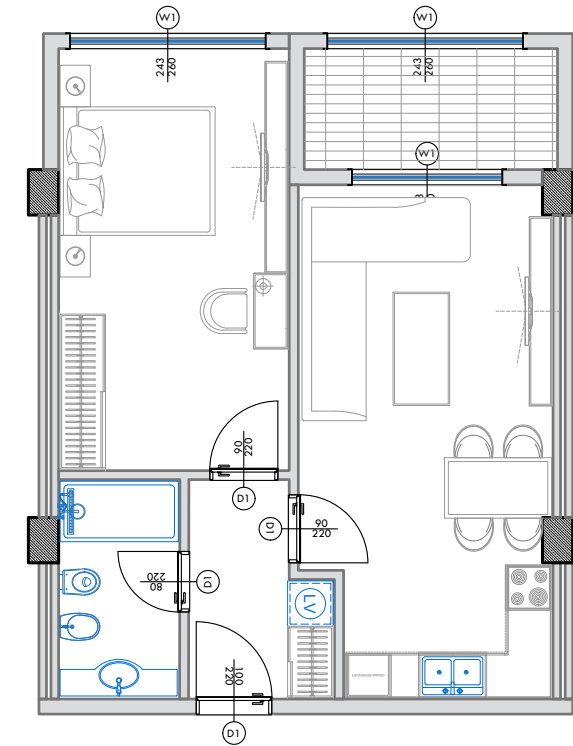
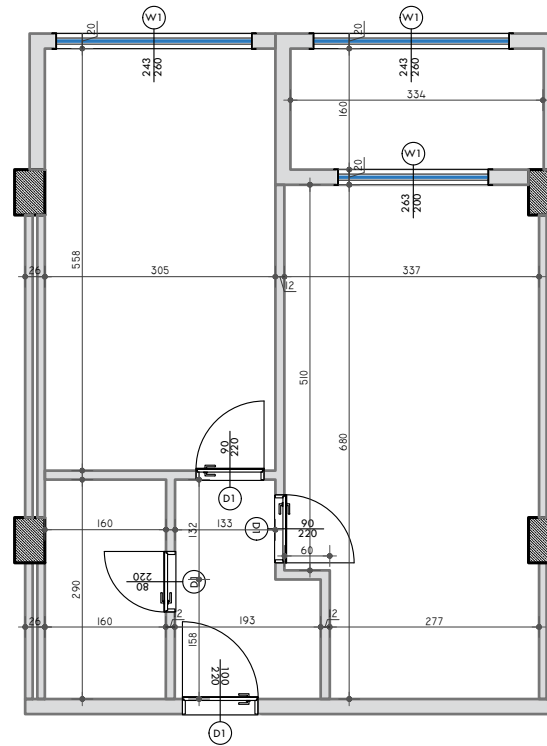

**PLANIMETRIA E APARTAMENTIT - PERMASIM**

**SHKALLA 1:100**

**PLANIMETRIA E APARTAMENTIT - MOBILIM**

**SHKALLA 1:100**

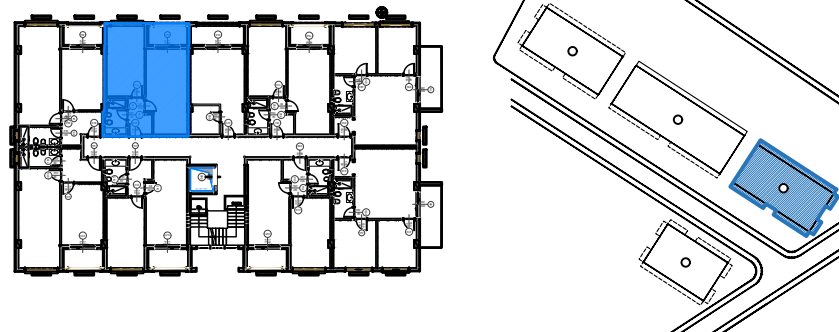

**POZICIONI I APARTAMENTIT NE PLANIMETRINE E KATIT**



**POZICIONI I APARTAMENTIT NE ALTIMETRI - FASADA VERIORE**



**PAMJE 3 DIMENSIONALE E APARTAMENTIT**

**NR.1**



**PAMJE 3 DIMENSIONALE E APARTAMENTIT**

**NR.2**

**“4 GODINA BANIMI DHE SHËRBIMI 5 KATE DHE 1 KAT PARKIM NËNTOKË”**  
**Adresa: Pavarsia e Kosovës, Golem - Bashkia Kavajë**

**INVESTITOR DHE SUBJEKT NDERTUES:**

**"LOREDIS" Sh.p.k**  
**NIPT: M32202503U**  
**Kavajë / Albania**  
**Tel: +355694080880**

**PROJEKTUES:**

**VAEKU STUDIO**  
**NIPT: M11319016N**  
**Adresa: "Kompleksi Magnet",**  
**Njësia Lyra 2018\_1**  
**Njësia Administrative Nr.7**  
**Tiranë/Albania**  
**E-mail: u.hoxha@vaeku.studio**  
**Tel: +355674088492**



**APARTAMENTI NR:**

**34**

**Objekti Nr :**

**3**

**Kati :**

**4**

**Orientimi :**

**VERI**

**Siperfaqe Apartamenti :**

**67.4 m<sup>2</sup>**

**Ambjente te perbashketa:**

**7.2 m<sup>2</sup>**

**Siperfaqe totale:**

**74.6 m<sup>2</sup>**

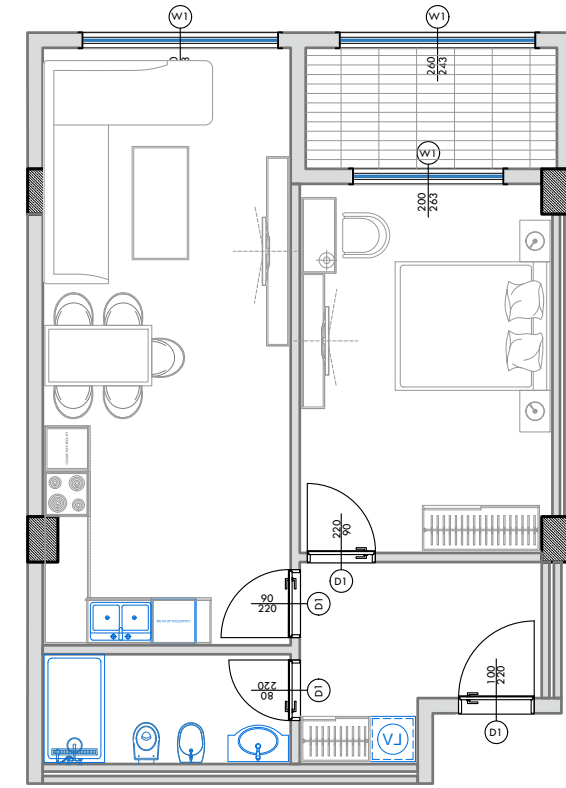
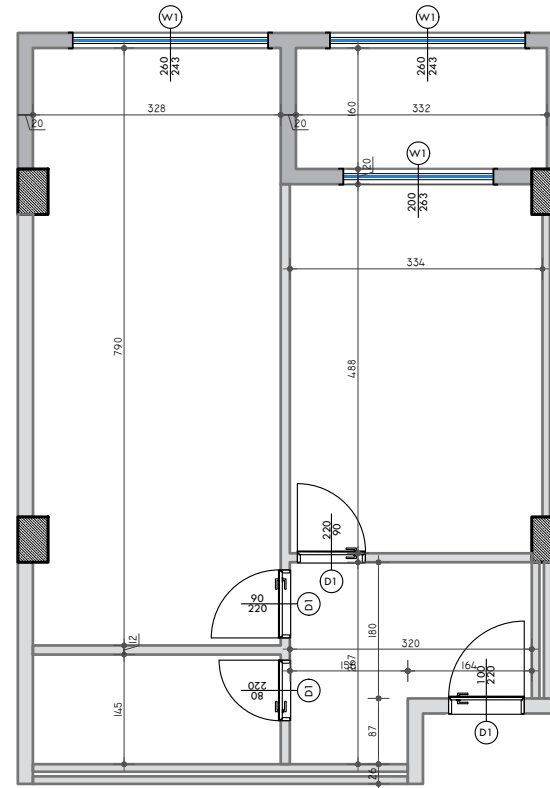

**PLANIMETRIA E APARTAMENTIT - PERMASIM**

**SHKALLA 1:100**

**PLANIMETRIA E APARTAMENTIT - MOBILIM**

**SHKALLA 1:100**

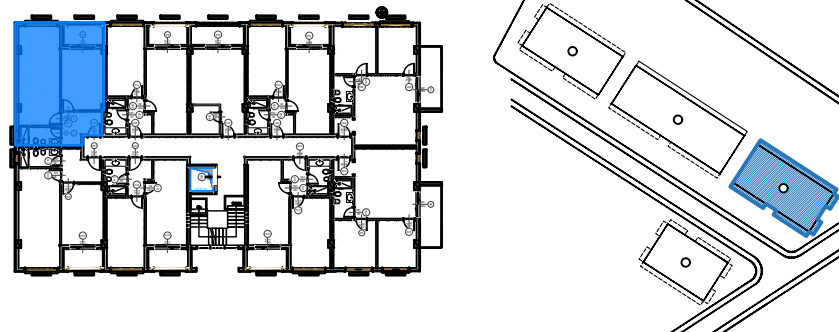

**POZICIONI I APARTAMENTIT NE PLANIMETRINE E KATIT**



**PAMJE 3 DIMENSIONALE E APARTAMENTIT**

**NR.1**



**PAMJE 3 DIMENSIONALE E APARTAMENTIT**

**NR.2**



**POZICIONI I APARTAMENTIT NE ALTIMETRI - FASADA VERIORE**

**“4 GODINA BANIMI DHE SHËRBIMI 5 KATE DHE 1 KAT PARKIM NËNTOKË”**  
**Adresa: Pavarsia e Kosovës, Golem - Bashkia Kavajë**

**INVESTITOR DHE SUBJEKT NDERTUES:**

**“LOREDIS” Sh.p.k**  
**NIPT: M32202503U**  
**Kavajë / Albania**  
**Tel: +355694080880**

**PROJEKTUES:**

**VAEKU STUDIO**  
**NIPT: M11319016N**  
**Adresa: “Kompleksi Magnet”,**  
**Njësia Lyra 2018\_1**  
**Njësia Administrative Nr.7**  
**Tiranë/Albania**  
**E-mail: u.hoxha@vaeku.studio**  
**Tel: +355674088492**



APARTAMENTI NR:	<b>35</b>
Objekti Nr :	3
Kati :	4
Orientimi :	JUG
Siperfaqe Apartamenti :	67.4 m <sup>2</sup>
Ambjente te perbashketa:	7.2 m <sup>2</sup>
Siperfaqe totale:	74.6 m <sup>2</sup>

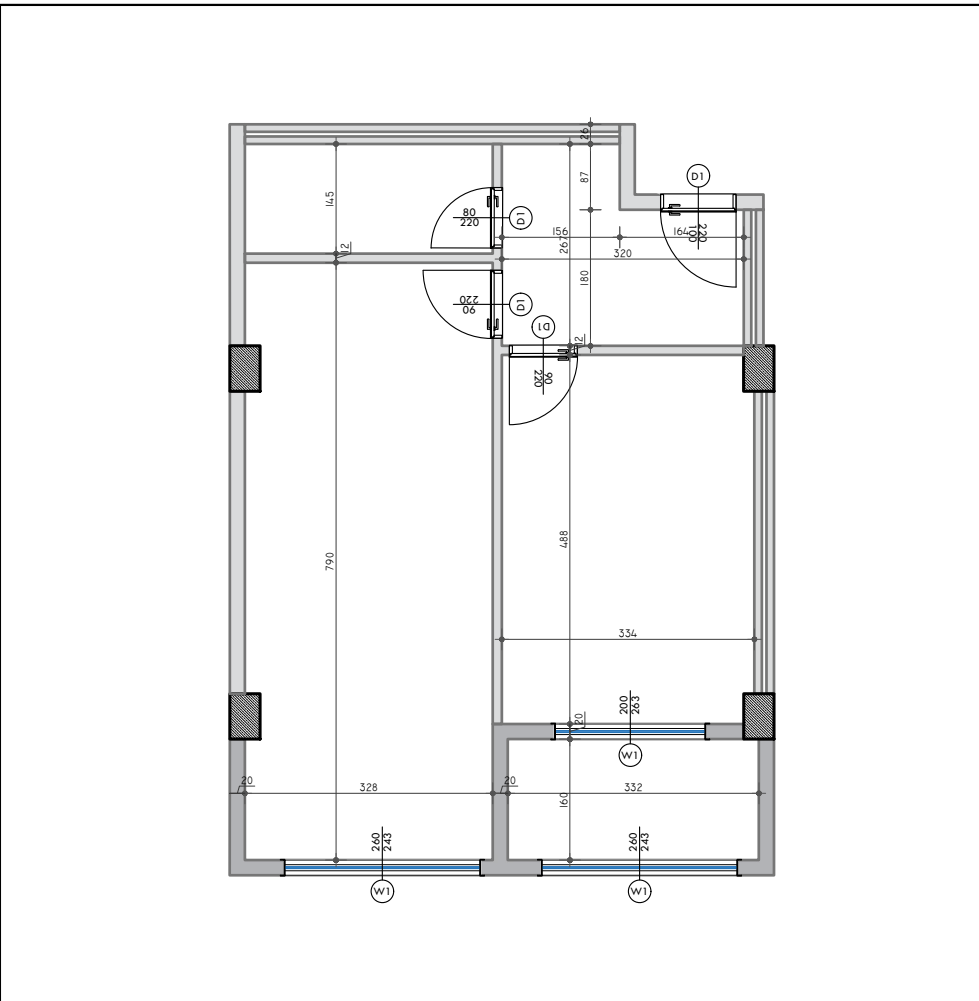

**PLANIMETRIA E APARTAMENTIT - PERMASIM**

**SHKALLA 1:100**

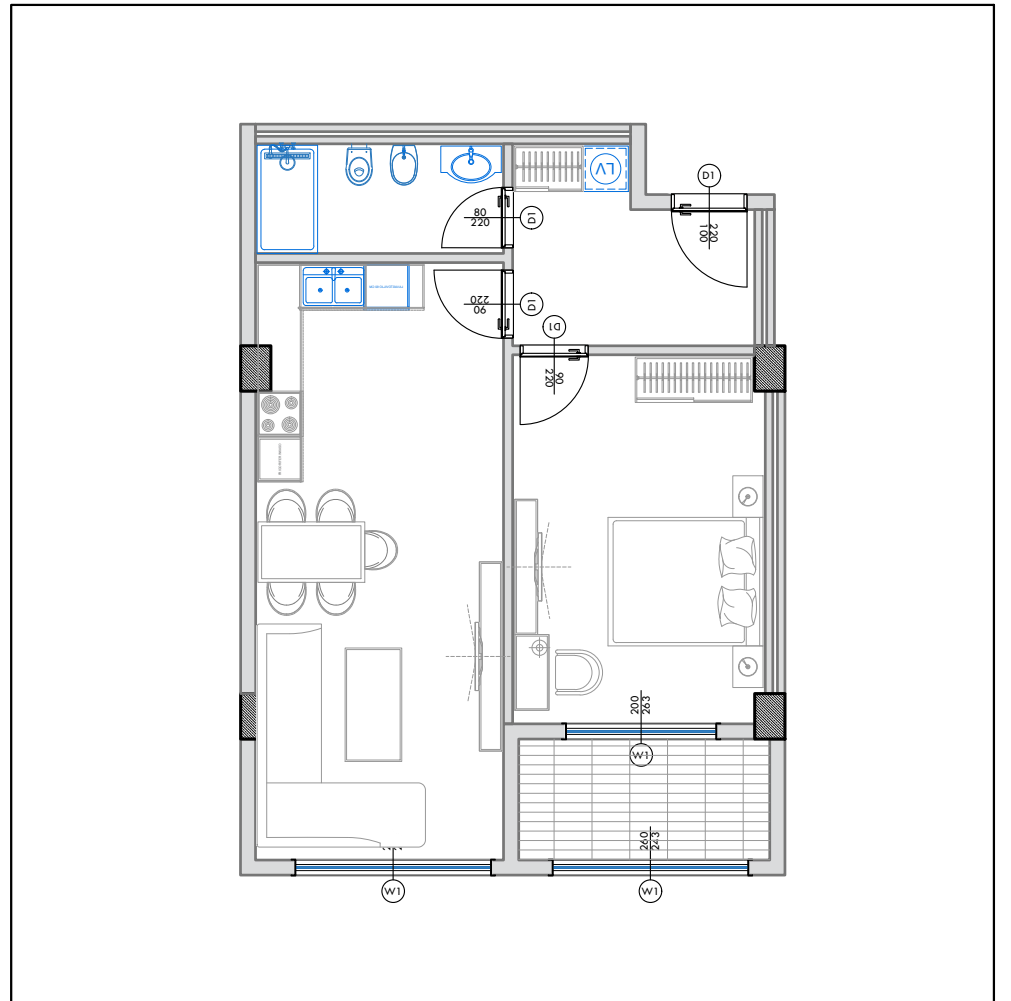

**PLANIMETRIA E APARTAMENTIT - MOBILIM**

**SHKALLA 1:100**

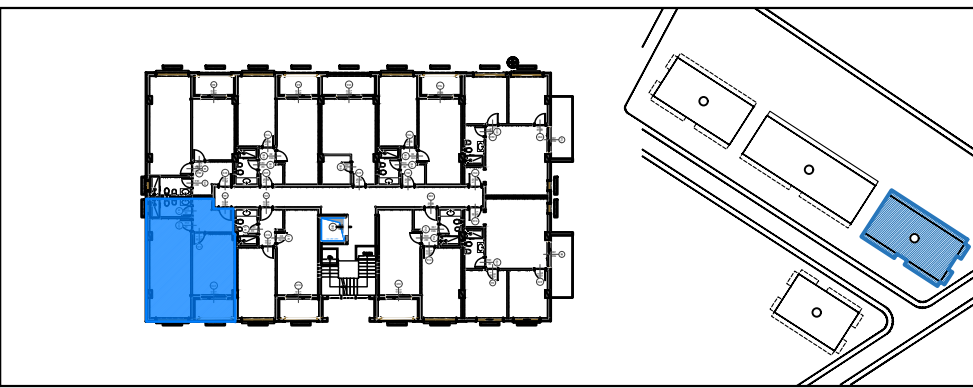

**POZICIONI I APARTAMENTIT NE PLANIMETRINE E KATIT**

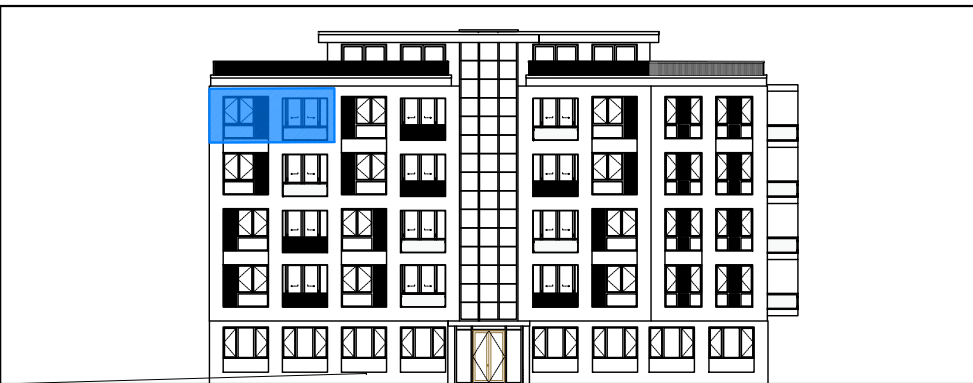

**POZICIONI I APARTAMENTIT NE ALTIMETRI - FASADA JUGORE**



**PAMJE 3 DIMENSIONALE E APARTAMENTIT**

**NR.1**



**PAMJE 3 DIMENSIONALE E APARTAMENTIT**

**NR.2**

**“4 GODINA BANIMI DHE SHËRBIMI 5 KATE DHE 1 KAT PARKIM NËNTOKË”**  
**Adresa: Pavarsia e Kosovës, Golem - Bashkia Kavajë**

**INVESTITOR DHE SUBJEKT NDERTUES:**

**"LOREDIS" Sh.p.k**  
**NIPT: M32202503U**  
**Kavajë / Albania**  
**Tel: +355694080880**

**PROJEKTUES:**

**VAEKU STUDIO**  
**NIPT: M11319016N**  
**Adresa: "Kompleksi Magnet",**  
**Njësia Lyra 2018\_1**  
**Njësia Administrative Nr.7**  
**Tiranë/Albania**  
**E-mail: u.hoxha@vaeku.studio**  
**Tel: +355674088492**



**APARTAMENTI NR:**

**36**

**Objekti Nr :**

**3**

**Kati :**

**4**

**Orientimi :**

**JUG**

**Siperfaqe Apartamenti :**

**61.0 m<sup>2</sup>**

**Ambjente te perbashketa:**

**6.5 m<sup>2</sup>**

**Siperfaqe totale:**

**67.5 m<sup>2</sup>**

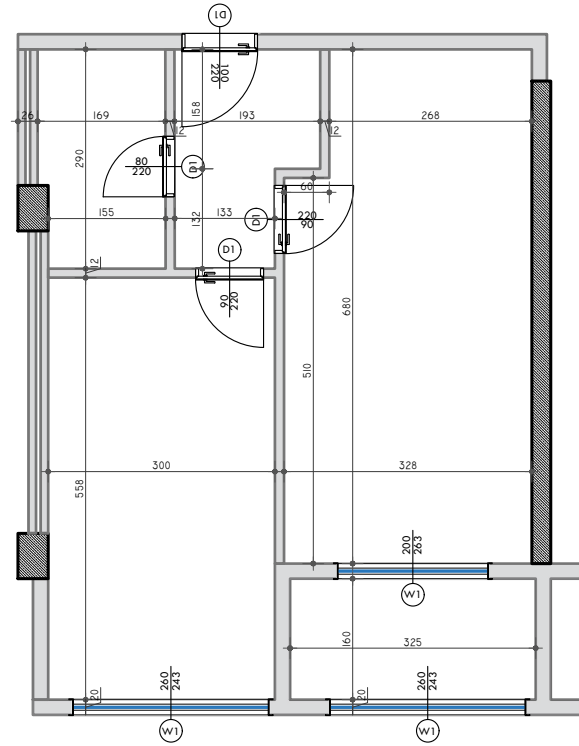

**PLANIMETRIA E APARTAMENTIT - PERMASIM**

**SHKALLA 1:100**

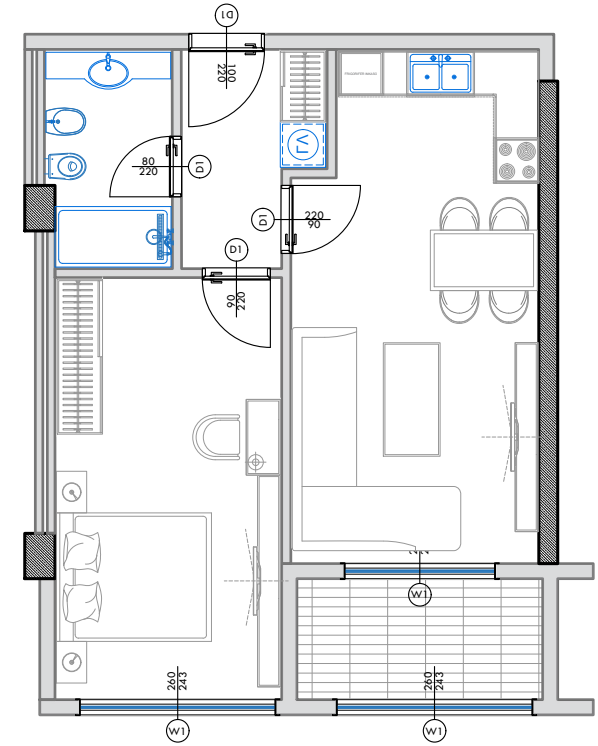

**PLANIMETRIA E APARTAMENTIT - MOBILIM**

**SHKALLA 1:100**

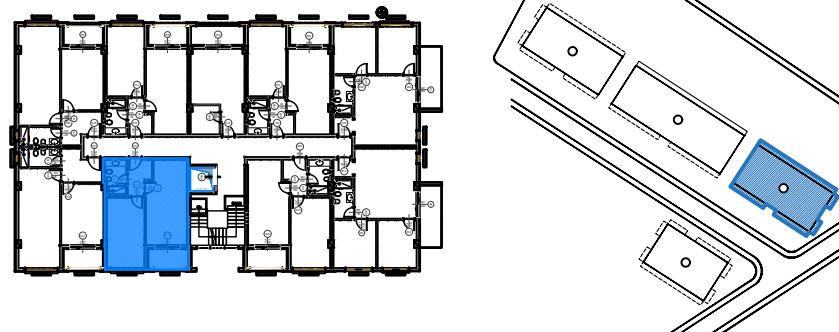

**POZICIONI I APARTAMENTIT NE PLANIMETRINE E KATIT**



**POZICIONI I APARTAMENTIT NE ALTIMETRI - FASADA JUGORE**



**PAMJE 3 DIMENSIONALE E APARTAMENTIT**

**NR.1**



**PAMJE 3 DIMENSIONALE E APARTAMENTIT**

**NR.2**